

CONCRETE AND CLAY ROOF TILE INSTALLATION MANUAL

**Florida Roofing, Sheet Metal and Air Conditioning
Contractors Association, Inc.**



Tile Roofing Institute



PREFACE

In January, 1987, the Roof Tile Committee of the FRSA/NTRMA was commissioned to develop and write consensus guidelines for the installation of concrete and clay roof tiles. Recently, the National Tile Roofing Manufacturers Association (NTRMA) changed its name to Tile Roofing Institute. The consensus document process included meetings over a period of eighteen (18) years, made up of roofing contractors, manufacturers, suppliers, academia, roofing consultants, and engineers.

These guidelines were approved by a consensus vote of participating members. These guidelines are updated or reaffirmed by the same process at intervals not exceeding three (3) years.

These guidelines were developed to summarize for the designer, applicator or developer good roofing practice and industry guidelines for the installation of the mechanically-set and mortar/ adhesive-set tiles, which have been developed over a period of time from actual trade practice and the requirements of various building code agencies. These guidelines may not be applicable in all geographical areas. It is the responsibility of those individuals who are referring to these guidelines to independently research and determine which is best for their particular project. Accordingly, the Florida Roofing, Sheet Metal and Air Conditioning Contractors Association and the Tile Roofing Institute and their members expressly disclaim any express or implied warranties or any liability for any damages or loss that might be incurred as a result of the use of these guidelines.

STANDARDS

This document incorporates by reference the following specifications and standards:

APA PS 1	Construction and Industrial Plywood
ASTM A 90	Standard Test Method for Weight (Mass) of Coating on Iron and Steel Articles with Zinc or Zinc-Alloy Coatings
ASTM A 653	Standard Specification for General Requirements for Steel Sheet, Zinc-Coated (Galvanized) by the Hot-Dip Process
ASTM A 641	Standard Specification for Zinc-Coated (Galvanized) Carbon Steel Wire
ASTM C 91	Standard Specification for Masonry Cement
ASTM C 144	Standard Specification for Aggregate for Masonry Mortar
ASTM C 150	Standard Specification for Portland Cement
ASTM C 270	Standard Specification for Mortar for Unit Masonry
ASTM C 332	Standard Specification for Lightweight Aggregates for Insulating Concrete
ASTM C 1167	Standard Specification for Clay Roof Tiles
ASTM C 1492	Standard Specification for Concrete Roof Tiles
ASTM D 226	Standard Specification for Asphalt-Saturated Organic Felt Used in Roofing and Waterproofing(Organic Felt) with Mineral Granules
ASTM D 312	Standard Specification for Asphalt Used in Roofing
ASTM D 1056	Standard Specification for Flexible Cellular Materials - Sponge or Expanded Rubber
ASTM D 1621	Standard Test Method for Compressive Properties of Rigid Cellular Plastics
ASTM D 1622	Standard Test Method for Apparent Density of Rigid Cellular Plastics
ASTM D 1623	Standard Test Method for Tensile and Tensile Adhesion Properties of Rigid Cellular Plastics
ASTM D 2126	Standard Test Method for Response of Rigid Cellular Plastics to Thermal and Humid Aging
ASTM D 2842	Standard Test Method for Water Absorption of Rigid Cellular Plastics
ASTM D 2626	Standard Specification for Asphalt-Saturated and Coated Organic Felt Base Sheet Used in Roofing
ASTM D 2856	Standard Test Method for Open Cell Content of Rigid Cellular Plastics by the Air Pycnometer
ASTM D 3019	Standard Specification for Lap Cement Used with Asphalt Roll Roofing
ASTM D 3498	Standard Specification for Adhesives for Field-Gluing Plywood to Lumber Framing for Floor Systems
ASTM D 4586	Standard Specification for Asphalt Roof Cement, Asbestos-Free
ASTM D 6162	Standard Specification for SBS Polyester and Glass Fiber Reinforcement Mat
ASTM D 6163	Standard Specification for SBS with Glass Fiber Reinforcement Mat
ASTM D 6164	Standard Specification for Polyester Reinforcement Mat
ASTM D 6380	Standard Specification for Asphalt Roll Roofing
ASTM E 84	Standard for Surface Burning Characteristics of Building Materials
ASTM E 96	Standard Test Methods for Water Vapor Transmission of Materials
ASTM E 108	Standard for Fire Tests of Roof Coverings
AWPI C 2	Standard for Lumber, Timber, Bridge Ties and Mine Ties - Preservative Treatment by Pressure Processes
F.S. QQ-L-201-F, Grade B or C	Federal Specification for Sheet Lead

PARTICIPATING TILE ROOFING INSTITUTE MEMBERS:

ALTUSA

COMA CAST CORP.

ENTEGRA SALES, INC.

DOW CHEMICAL

LUDOWICI ROOF TILE, INC.

MCA CLAY ROOF TILE

MONIERLIFETILE

HANSON ROOF TILE

POLYFOAM PRODUCTS, INC.

QUIK DRIVE USA, INC.

RINKER CEMENT CO.

U.S. TILE CO.

VANDE HEY - RALEIGH MFG., INC.

WESTILE ROOFING PRODUCTS

ACKNOWLEDGMENTS

The FRSA/TRI acknowledges the devoted efforts of the joint Task Force of the FRSA/TRI. This group is comprised of roofing contractors, manufacturers, suppliers, academia, roofing consultants, and engineers. This Manual was prepared through the consensus guidelines process.

The following individuals served on the Task Force:

Dale Adams	Michael Gustafson	Bob Purdy
W.L. Albritton	Greg Hageman	Gary Register
Craig Anderson	Mike Harak	Robert Ruiz
Daniel Bernal	Paul Hayes	Chris Schulte
Richard Beymer	Bob Hightower	Walter Scott
Bill Bieler	Robbie Hightower	David Shewski
Earl Blank	Bob Hilson	Robert Shluzas
Brad Bowen, III	Jim Horton	Alvin J. Singleton
Ted Bowers	John Hosford, III	David Snyder
Charles Breslauer	Lew Howell	Robert Shluzas
Jack Brown	Mark Howland	Mike Silvers
Joe Bruckner	Terry Johnson	Loyal Slechta
Bill Bryans	Richard Kaspar	Phil Spake
Joseph Byrne	Les Knopf	Tom Stanley
John Campbell	Rob Kornahrens	Cris Starr
Randall Carney	Barbara Lamb	Dave Stephens
Danny Carson	Robert Leslie	Marvin Stokoe
Bryan Cassell	Deborah Liftig	Cliff Stutts
Jim Cheshire	Scott Lelling	Bob Sutphin
Billy Cone	Sean Lilly	Morris Swope
Jack Craig	Brent Lloyd	Doug Tait
Paul Croushore	Burt Logan	Gary Thomas
Eddie Currier	Stuart Lyons	Milton E. Thompson
Forest Dean	Bruce Manson	Bill Tucker
Clyde Denning	Sam Mattina	Gary Vogt
George Desiderio	John Mayo	Gary Waldrep
S. Anthony DeVito	Bob McDonald	Tim Wallace
Les Dickson	Ted McGee	Kevin Watson
Rick Divins	Fernando Mendez	Keith Wesche
Jody Dove	Manny Mendez	Bob Whatley
Drew Duncan	Walt Millet	Andy Wieland
Mike Duskin	Brad Molter	David Williams
Ed Engelmeier	Reese Moody	Gerry Williams
Robert Ethridge	Hans Mordrin	Anthony Wilson
David Faulkner	Greg Motter	Carol Youmans
Bob Ferrante	Dave Noel	Joe Zambruski
Barbara Fleck	David Packard	Mark Zirzow
Mike Fulton	Richard Pepin	
Herbert Frank	George Peterson	
Thomas C. Gans	Gregory Pierce	
Charles Goldsmith	Bob Pike	
Les Gory	Arturo Posada	

TABLE OF CONTENTS

	Page
SYSTEM ONE	
Unsealed or sealed underlayment system using preformed metal flashings with edge returns. Tiles are applied over the underlayment with mechanical fasteners to the deck with or without horizontal battens.	1
QUICK REFERENCE CHART - TABLE 1	2
PART I - GENERAL	
1.01 Related Work Elsewhere	3
1.02 Quality Assurance	3
1.03 Submittals	3
1.04 Product Delivery, Storage and Handling	3
1.05 Job Conditions	3
1.06 Warranty	3
PART II - PRODUCTS	
2.00 Disclaimer Notice	4
2.01 Roof Tile	4
2.02 Asphalt Saturated Roofing Underlayments	4
2.03 Membranes	4
2.04 Fasteners	4
2.05 Metal Flashings	5
2.06 Asphaltic Adhesive	5
2.07 Adhesive/Sealants	5
2.08 Mortar	5
2.09 Eave Closure	5
2.10 Coatings	5
2.11 Sheathing	5
PART III - EXECUTION	
3.01 Inspection	6
3.02 Underlayment Application	6
3.03 Drip Edge Metal	8
3.04 Gable Treatment	8
3.05 Valleys (underlayment)	9
3.06 Valley Termination onto Roof Plane	11
3.07 Flashing and Counter Flashings at Wall Abutments	11
3.08 Head and Apron Flashing	12
3.09 Standard Curb Mounted Skylights, Chimneys, Etc.	14
3.10 Pipes, Turbines, Vents, Etc.	15
3.11 Batten Installation	16
3.12 Tile Installation	17
3.13 Flat / Low, Medium and High Profile Tile	19
3.14 Valleys (Tiles)	20
3.15 Hip Starter	21
3.16 Hip and Ridge Installation	21

	Page
3.17 Hip and Ridge Nailer Boards	21
3.18 Rake/Gable Tile	21
3.19 Wall Abutments (Tile)	21
3.20 Coatings	21
3.21 Tile Replacement	21
3.22 Clean-up	21
3.23 Miscellaneous Recommendations	21
SYSTEM TWO	
Sealed underlayment system using standard metal flashings. Tiles are applied with mechanical fasteners direct to waterproofed deck.	22
QUICK REFERENCE CHART - TABLE 1	23
PART 1 - GENERAL	
1.01 Related Work Elsewhere	24
1.02 Quality Assurance	24
1.03 Submittals	24
1.04 Product Delivery, Storage and Handling	24
1.05 Job Conditions	24
1.06 Warranty	24
PART II - PRODUCTS	
2.00 Disclaimer Notice	25
2.01 Roof Tile	25
2.02 Asphalt Saturated Roofing Underlayments	25
2.03 Membranes	25
2.04 Fasteners	25
2.05 Metal Flashing	25
2.06 Asphaltic Adhesive	26
2.07 Adhesive/Sealants	26
2.08 Mortar	26
2.09 Eave Closure	26
2.10 Coating	26
2.11 Sheathing	26
PART III - EXECUTION	
3.01 Inspection	27
3.02 Underlayment Application	27
3.03 Drip Edge Metal	29
3.04 Valleys	30
3.05 Flashing and Counter Flashings at Wall Abutments	33
3.06 Standard Curb Mounted Skylights, Chimneys, Etc.	36
3.07 Pipes, Turbines, Vents, Etc.	36
3.08 Tile Installation	38
3.09 Flat, Low and High Profile Tile	40
3.10 Valleys (Tiles)	41

	Page
3.11 Hip Starter	42
3.12 Hip and Ridge Installation	42
3.13 Hip and Ridge Nailer Boards	42
3.14 Rake/Gable	43
3.15 Wall Abutments	43
3.16 Plumbing Stacks	43
3.17 Coatings	43
3.18 Tile Replacement	43
3.19 Clean-up	43
3.20 Miscellaneous Recommendations	43

SYSTEM THREE

Sealed underlayment system using standard metal flashings. 44
 Tiles are applied with mortar direct to waterproofed deck.

QUICK REFERENCE CHART - TABLE 1 45

PART I - GENERAL

1.01 Related Work Elsewhere	46
1.02 Quality Assurance	46
1.03 Submittals	46
1.04 Product Delivery, Storage and Handling	46
1.05 Job Conditions	46
1.06 Warranty	46

PART II - PRODUCT

2.00 Disclaimer Notice	47
2.01 Roof Tile	47
2.02 Asphalt Saturated Roofing Underlayments	47
2.03 Membranes	47
2.04 Fasteners	47
2.05 Metal Flashings	47
2.06 Asphaltic Adhesive	48
2.07 Adhesive/Sealants	48
2.08 Mortar	48
2.09 Eave Closure	48
2.10 Coatings	48
2.11 Sheathing	48

PART III - EXECUTION

3.01 Inspection	48
3.02 Underlayment Application	48
3.03 Drip Edge Metal	50
3.04 Valleys	50
3.05 Flashing and Counter Flashings at Wall Abutments	52
3.06 Standard Curb Mounted Skylights, Chimneys, Etc.	52
3.07 Pipes, Turbines, Vents, Etc.	56
3.08 Tile Installation	58

	Page
3.09 Flat/Low, Medium and High Profile Tile	60
3.10 Valleys	64
3.11 Hip Starter	64
3.12 Hip and Ridge Installation	64
3.13 Hip and Ridge Nailer Boards	65
3.14 Rake/Gable	65
3.15 Wall Abutments	66
3.16 Plumbing Stacks	66
3.17 Coatings	66
3.18 Tile Replacement	66
3.19 Clean-up	66
3.20 Miscellaneous Recommendations	66
SYSTEM FOUR	
Option “A” — Unsealed or sealed underlayment system using preformed metal flashings with edge returns. Tiles are applied over the underlayment with adhesive to the deck with or without horizontal battens.	67
Option “B” — Sealed underlayment system using standard metal flashings. Tiles are applied with adhesive direct to waterproofed deck.	
DIVISION 7	68
PART 1 - GENERAL	
1.01 Related Work Specified Elsewhere	68
1.02 Quality Assurance	68
1.03 Submittals	68
1.04 Product Delivery, Storage and Handling	68
1.05 Job Conditions	68
1.06 Warranty	68
PART 2 - PRODUCTS	
2.00 Disclaimer Notice	69
2.01 Roof tile	69
2.02 Asphalt Saturated Roofing Underlayments	69
2.03 Membranes	69
2.04 Fasteners	69
2.05 Metal Flashing	69
2.06 Asphaltic Adhesive	70
2.07 Roof Tile Adhesive	70
2.08 Mortar	70
2.09 Polyurethane adhesives	70
2.10 Eave Closure	70
2.11 Coating	70
2.12 Sheathing	71

	Page
QUICK REFERENCE CHART - UNDERLAYMENT OPTION “A”	72
SYSTEM #4 - OPTION “A”	
3.02 Underlayment Application	73
3.03 Drip Edge Metal	75
3.04 Gable treatment	75
3.05 Valleys	76
3.06 Valley or Wall Flashings Termination onto Roof Plane	76
3.07 Flashing and Counter Flashings at all Abutments	77
3.08 Head & Apron Flashing	78
3.09 Standard Curb Mounted Skylights, Chimneys, Etc.	78
3.10 Pipes, Turbines, Vents, Etc.	81
3.11 Batten Installation	82
QUICK REFERENCE CHART - UNDERLAYMENT OPTION “B”	83
SYSTEM #4 - OPTION “B”	
3.02 Underlayment Application	84
3.03 Eave Drip Metal	85
3.04 Valleys	85
3.05 Flashing and Counter Flashing at Wall Abutments	88
3.06 Standard Curb Mounted Skylights, Chimneys, Etc.	90
3.07 Pipes, Turbines, Vents, Etc.	90
PART IV - TILE APPLICATION	
4.01 Tile Layout	94
4.02 Tile Installation	95
4.03 Flat / Low, Medium and High Profile Tile	96
4.04 Two Piece Barrel Tile	97
4.05 Valleys	98
4.06 Hip and Ridge Nailer Boards	99
4.07 Hip Starter	99
4.08 Hip and Ridge Installation	99
4.09 Rake/Gable Tile	99
4.10 Wall Abutments	100
4.11 Plumbing Stacks	100
4.12 Coatings	100
4.13 Tile Replacement	100
4.14 Clean-Up	100
4.15 Miscellaneous recommendations	100
APPENDIX	101
GLOSSARY OF TERMS	128
INSTRUCTIONS FOR HIP AND RIDGE ATTACHMENT	See Special Back Section

FRSA & TRI MODEL TILE GUIDELINES

System One

Mechanically Fastened Tile Guidelines

Unsealed or sealed underlayment system using preformed metal flashings with edge returns. Tiles are applied over the underlayment with mechanical fasteners to the deck with or without horizontal battens.

DISCLAIMER NOTICE (PLEASE READ CAREFULLY):

These mechanically fastened tile guidelines are a consensus document developed by a joint Task Force of the Florida Roofing, Sheet Metal and Air Conditioning Contractors Association (FRSA) and the Florida Chapter of the Tile Roofing Institute (TRI). It is important to recognize that these recommendations are neither warranties, explicit or implicit, nor representative of the only method by which a mechanically fastened tile system can be installed. Rather, they try to summarize for the designer, applicator or developer good roofing practice and some of the industry standards for the installation of the mechanically-set tiles which have been developed over a period of time from actual trade practice and the requirements of various building code agencies. These guidelines may not be applicable in all geographical areas. **It is the responsibility of those individuals who are referring to these guidelines to independently research and determine which is best for their particular project.**

System One

Mechanically Fastened Tile Guidelines

NOTE: The following table provides the contractor with the choices available for underlayment systems. These systems can only be used on pitches designated in the table below:

Slope of Roof	Battens or Direct Deck	Choice of Underlayments	Plastic or Compatible Cement at Fasteners Penetrating Underlayments	Reference
4":12" and greater	See 3.02A	1. Single-ply No. 43 or 90# Organic Cap Sheet or Modified Cap Sheet	Not Required	3.02A
4":12" and greater	Battens or Deck	2. Hot Mop Application - No. 30 or No. 43 /90# Organic or Modified Cap Sheet	Not Required	3.02B
4":12" and greater	Battens or Deck	3. Cold Process Application - No. 30 or No. 43/90# Organic or Modified Cap Sheet	Not Required	3.02C
4":12" and greater	Battens	4. Two Ply No.30 or No. 43, Underlayment	Not Required	3.02D
4":12" and greater	Battens or Deck	5. Self-Adhered Underlayment -Applied Direct to Wood Deck	Not Required	3.02E
4":12" and greater	Battens or Deck	6. No.30/Self-Adhered Underlayment	Not Required	3.02F
As Tested	Battens or Deck	7. Alternative Membranes	Not Required	3.02G

NOTE: Some products are not designed to be installed on this system. It is very important you check with the roof tile manufacturer for the approved profiles. Battens are optional from 4:12 up to and including 7:12 slope.

DIVISION 7

These guidelines cover Flat/Low, Medium and High Profile Roof Tile, using a minimum 3” tile headlap, or a designed limited headlap, on minimum 15/32” solid decking nailed in compliance with wind load requirements.

- 07300 -Shingles and Roofing Tiles
- 07320 -Roofing Tiles
 - Mechanically Fastened Tile Guidelines

PART I - GENERAL

- 1.01 Related Work Specified Elsewhere
 - A. Rough Carpentry - Section 06100
 - B. Roof and Deck Insulation - Section 07220.
 - C. Flashing and Deck Insulation - Section 07600.
 - D. Roof Accessories - Section 07700.
- 1.02 Quality Assurance
 - A. Products
 - 1. Concrete Roof Tile – In compliance with ASTM C 1492.
 - 2. Clay Roof Tile - In compliance with ASTM Standard C 1167.
 - B. Tile Attachment – Shall be in compliance with:
 - 1. ICC-SSTD-11
 - or,
 - 2. TAS 101
- 1.03 Submittals
 - A. Samples - tile type and color as selected.
 - B. Manufacturer’s literature - including product descriptions and recommended installation procedures.
 - C. Tile Compliance Report.
- 1.04 Product Delivery, Storage and Handling
 - A. Distribute stacks of tile uniformly, not in concentrated loads.
 - B. When conditions warrant, install temporary battens to facilitate roof loading.
 - C. Care shall be taken to protect the underlayment during the tile loading and stacking process.
- 1.05 Job Conditions
 - A. Do not install underlayment on wet surfaces.
 - B. Ensure other trades are aware of precautions required when loading and stacking of tile, and their responsibility for protection of tile after loading and stacking is completed.
 - C. Any punctures or tears in the underlayment which occur during the loading and stacking of tile shall be immediately repaired with like materials.
- 1.06 Warranty
 - A. Materials - manufacturer’s limited warranty against defects in roof tile for ___ years
(**NOTE:** Fill in appropriate number of years).

PART II - PRODUCTS

- 2.00 **DISCLAIMER NOTICE:** The FRSA and TRI rely on component industry data to establish minimum physical properties standards for their products. The standards listed in the Products section of this manual reflect that process.
- 2.01 Roof tile
- A. Tile Manufacturer: _____
 - B. Tile Type: _____
 - C. Approximate Weight: _____
- 2.02 Asphalt Saturated Roofing Underlayments
- A. Organic, type II, commonly called No. 30 or 30#, conforming to ASTM Standard D 226, type II organic saturated.
 - B. Asphalt - saturated and coated organic felt base sheet, commonly called No. 43 or 43#, per roll, conforming to ASTM D 2626.
 - C. Mineral surface roll roofing minimum 74 # per roll commonly called 90#, conforming to ASTM D 6380.
 - D. Modified bitumen single ply membrane, minimum 40 mils.
 - E. Self -adhered membrane, minimum 40 mils.
 - F. Granular surface SBS modified bitumen membrane, minimum 40 mils. at the selvage edge.
- 2.03 Membranes
- A. Organic - Asphalt impregnated cotton membrane, minimum 4" wide.
 - B. Inorganic - Asphalt impregnated fiberglass membrane, minimum 4" wide.
- 2.04 Fasteners
- A. Tile Fasteners
 - 1. Nails - corrosion resistant meeting ASTM A 641 Class 1 and/or corrosion resistance equal (according to ASTM B 117) of sufficient length to penetrate a minimum 3/4" into or through thickness of the deck or batten.
 - a. Ring shank nails shall be 10d ring shank corrosion resistant steel nails (3 inches long, 0.283 inch flat head diameter, 0.121 inch shank diameter, 18-22 rings per inch).
 - 2. Screw Fasteners - corrosion resistant meeting ASTM A 641 Class 1 and/or corrosion resistance equal (according to ASTM B 117). Screws shall be 2 1/2" in length or penetrate a minimum 3/4" into the deck or batten. ASTM A 641 Class 1 is a nail specification that can be converted to screw fasteners through performance testing (ASTM B 117). Each fastener manufacturer is responsible for supplying this support data.
 - a. Minimum #8 course thread.
 - 3. Tile fasteners shall be compatible with batten material.
 - B. Underlayment Fasteners
 - 1. Nails or cap nails shall be of sufficient length to properly penetrate 3/4" into or through thickness of deck.
 - a. Minimum #11 gauge.
 - 2. Tin tags - not less than 1-5/8" nor greater than 2" in diameter and a minimum 32 gauge steel sheet metal.
 - a. Minimum #32 gauge sheet metal.
 - C. Batten Fasteners – Batten fasteners shall be compatible with batten material.

- 2.05 Metal Flashing
- A. Flashing shall be minimum 26 ga., G-90 corrosion resistant metal - conforming to ASTM A 525 and ASTM A 90, or other metal or composition profile materials as listed in the building code.
 - B. Lead for soil stacks shall be minimum 2.5 # per sq. ft. Lead weight flashing requirements follow Lead Association recommendation.
- 2.06 Asphaltic Adhesive
- A. Asphalt plastic roof cement - conforming to ASTM D 4586, type II, non-asbestos, non-running, heavy body material composed of asphalt and other mineral ingredients.
 - B. Cold process modified bitumen roofing mastic - conforming to ASTM D 3019, type III.
 - C. Asphalt - conforming to ASTM D 312, type III or IV (Note slope requirements in the building code).
- 2.07 Adhesive/Sealants
- A. Structural bonding adhesive - conforming to ASTM D 3498.
- 2.08 Mortar
- A. Materials
 1. Cement shall conform to ASTM C 91 Type M.
 2. Aggregates
 - a. Sand shall meet ASTM C 144, uniformly graded; clean and free from organic materials.
 - b. Lightweight aggregate shall meet ASTM C 332.
 - B. Mixes
 1. All mortar used to fasten field tiles shall be factory premixed and bagged and shall a FBC (Florida Building Code) product approval.
 2. All mortar used to fasten hips and ridges shall, in addition to having a FBC product approval, be tested in accordance with ICC-SSTD-11 data substantiating compliance.
 3. Job proportioned mixes (job site mortars) may be used for cosmetic purposes and for “wind block” only.
- 2.09 Eave Closure
- A. Prefabricated EPDM synthetic rubber conforming to ASTM D 1056.
 - B. Prefabricated metal eave closure.
 - C. Prefabricated concrete or clay eave closure.
- 2.10 Coating
- A. Paint - color coordinated paint for painting tile, flashing and/or accessories (optional).
 - B. Sealer - for point-up mortar (optional).
 - C. Tint Seal - color coordinated sealer for staining tile or accessories (optional).
- 2.11 Sheathing - Material shall conform to APA rated sheathing.
- NOTE:** Refer to building code wind load requirements.
- A. Minimum span rated 32/16; 15/32” thick APA rated sheathing.
 - B. Battens - material to be decay resistant.
 1. Battens should not be bowed or twisted.
 2. Horizontal battens should be nominal 1” x 2”.
 - C. Nailer Boards - Material to be decay resistant
 1. Nailer boards should not be bowed or twisted.
 2. Nailer boards shall be a nominal 2 inches x (sufficient height to satisfy conditions).

PART III - EXECUTION

3.01 Inspection

- A. Verify that surfaces to receive underlayments are uniform, smooth, clean and dry.
- B. Proper ventilation is recommended on all tile applications. Verify ventilation requirements as set forth in the building code.

3.02 Underlayment Application - Choose one of the following:

NOTE: On cap sheet, cut fishmouths and seal with compatible flashing cement and membrane where applicable.

NOTE: A No.15, No.30 or No.43 can be used as a dry in prior to installing the underlayment with this system (except on 3.02 E).

A. Single-ply No.43 or 90# Organic Cap Sheet or Modified Cap Sheet (See Drawing 1)

A single-ply No.43 underlayment application shall be installed under mandatory use of battens. A 90# organic cap sheet or modified cap sheet underlayment application can be installed with tiles applied direct to the cap sheet. Prior to applying the No.43, 90# or modified cap sheet, attach a 36" wide strip of same underlayment, (sweat sheet) down the center of the valley. Secure near the edge of the felt 24" on center. Apply a No.43 or 90# or modified cap sheet perpendicular to the slope of the roof and mechanically attached to the wood deck with nails and tin caps, round cap nails or other fasteners spaced 36" on center near the top edge of felt. Use a minimum 4" head lap and 6" side laps. Extend underlayment sheet up vertical surfaces a minimum 4". Overlap hip and ridges a minimum of 6". Secure near the edge of felt 12" on center at overlaps and side laps of the underlayment.

DRAWING 1

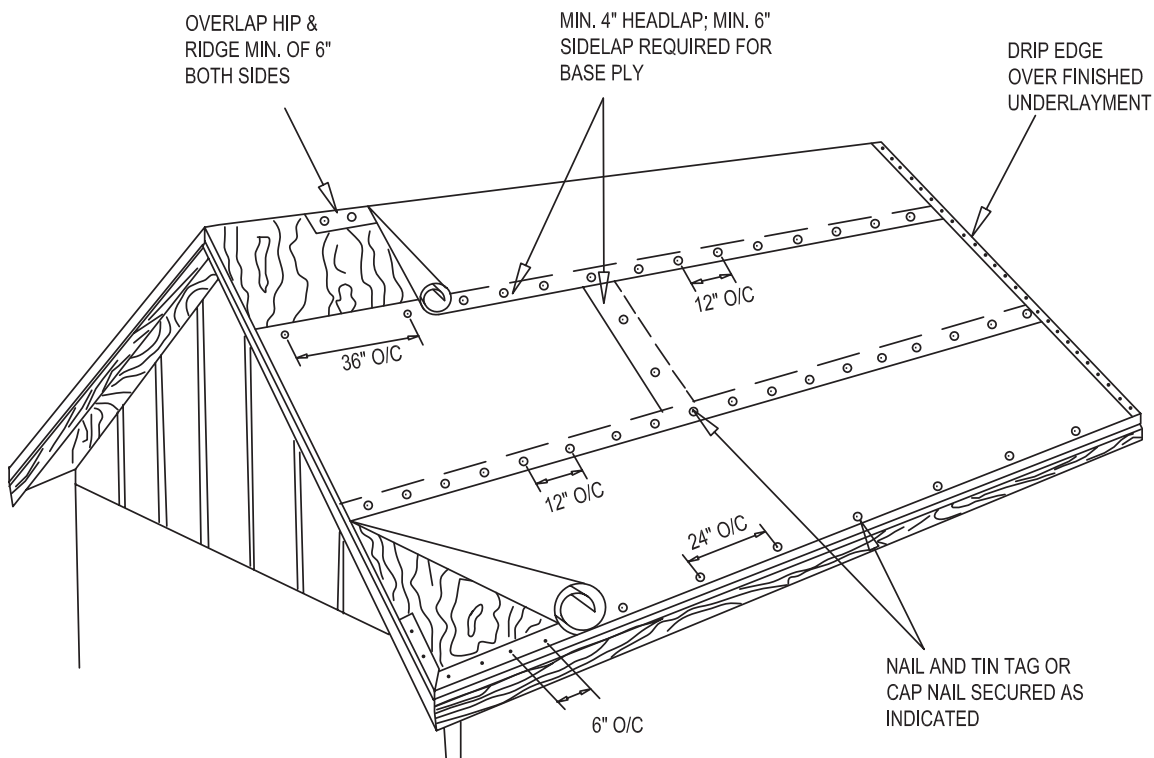

- B. Hot Mop No.30 or No.43 / 90lb. Organic or Modified Cap Sheet (See Drawing 2)
 A two ply roof application commonly called a ‘Hot Mop’ system. A No.30 or No.43 base sheet shall be mechanically attached to the wood deck with nails and tin caps, round cap nails or other fasteners spaced in a 12” grid staggered in two rows in the field, and 6” on center at the laps. Extend base sheet a minimum of 4” up vertical surfaces. Base side laps shall be a minimum of 6” and head laps shall be a minimum of 2”. Over installed base sheet, apply a layer of organic cap sheet in an application rate of 25 #/sq. ± 15% mopping of asphalt. With this system the cap sheet may come in contact with the base sheet, allowing felt to touch felt. Side laps shall be a minimum of 6”; head laps shall be a minimum of 3” and back nailed 12” on center.
- C. Cold Process Application - No.30 or No.43/90# Organic or Modified Cap Sheet (See Drawing 2)
 A two ply roof application commonly called a ‘Cold Process’ system. A No.30 or No.43 base ply sheet shall be mechanically attached to the wood deck with nails and tin caps, round cap nails or other fasteners spaced in a 12” grid staggered in two rows in the field, and 6” on center at the laps. Extend base ply sheet a minimum of 4” up vertical surfaces. Base ply side laps shall be a minimum of 6” and head laps shall be a minimum of 2”. Over installed base sheet, apply a cap sheet according to underlayment/adhesive manufacturer recommendations. Cap sheet side laps shall be a minimum of 6”; head laps shall be a minimum of 3” and back nailed 12” on center.
- NOTE:** For Cold Process-Systems, in windy conditions, it may be necessary to spot nail cap sheet laps at a maximum of 3’ on center.

DRAWING 2

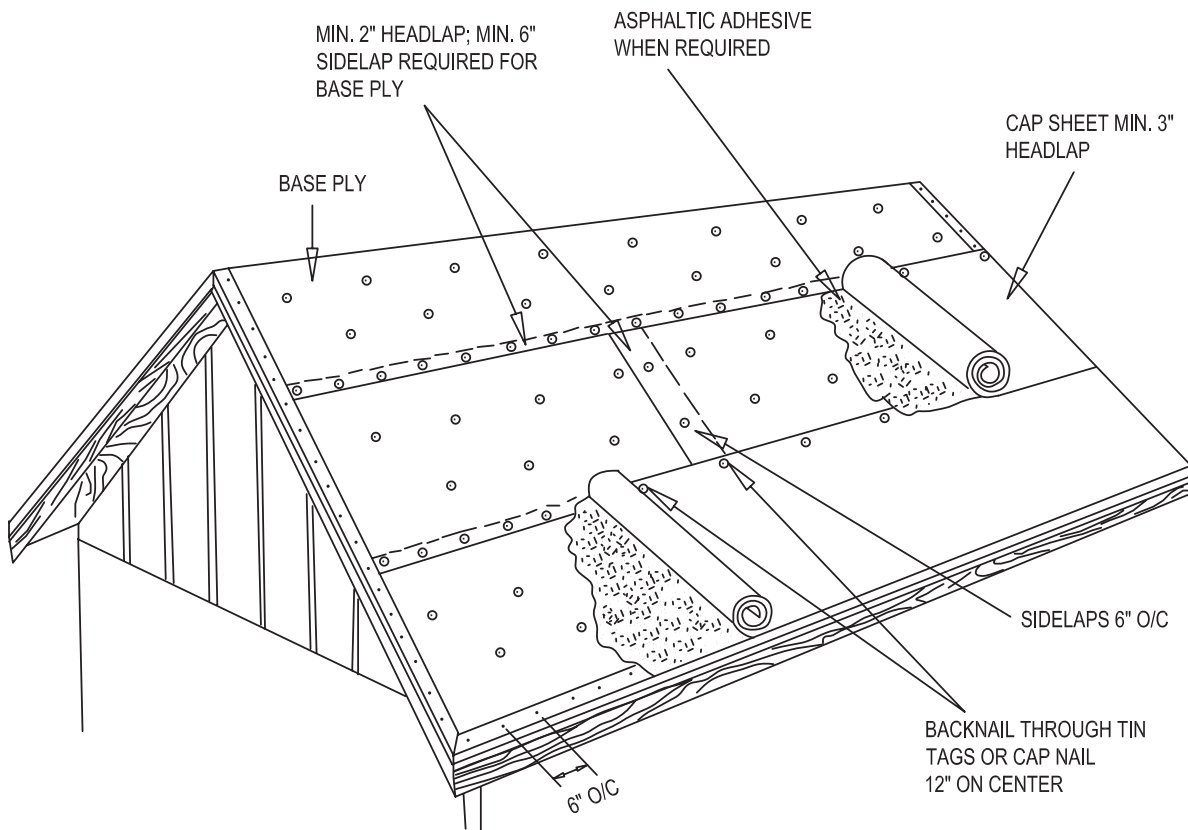

D. Two Ply No. 30 or No.43 Underlayment

This underlayment application is installed under the mandatory use of battens. A 19” wide starter strip of a No. 30 or No.43 underlayment shall be applied horizontally at the eaves. A full 36” width sheet shall be applied covering the starter sheet. The starter sheet and each succeeding full width sheet of felt shall be mechanically attached to the wood deck with nails and tin caps, round cap nails or other fasteners spaced 24” on center, 1” from the top edge of felt and 12” on center at the laps. Succeeding sheets shall be lapped 19” (17” exposure) over the preceding sheets. Extend base sheets a minimum of 4” up vertical surfaces. Side laps shall be 6”.

E. Self-Adhered Underlayment - Applied Direct to Wood Deck.

A single ply underlayment system utilizing self-adhered underlayment. Apply one layer of self-adhered underlayment in compliance with the self-adhered underlayment manufacturers’ recommendations.

F. No.30/Self-Adhered Underlayment

A two ply roof application utilizing a self-adhered underlayment. No.30 felt shall be mechanically attached to the wood deck with nails and tin caps, round cap nails or other fasteners spaced 12” on center at the laps. Extend base ply sheet a minimum of 4” up vertical surfaces. Base sheet side laps shall be a minimum of 6” and head laps shall be a minimum of 2”. Over base sheet, apply one layer of self-adhered underlayment in compliance with the self-adhered underlayment manufacturers’ recommendation. Backnail the self-adhered underlayment a minimum of 12” on center.

G. Alternative Membranes

Any product consisting of one or more water shedding layers applied to a sloped roof prior to the application of a prepared roof covering having been tested in compliance with the building code. The primary purpose of an underlayment is defined as a water shedding layer to function in combination with a prepared roof covering.

3.03 Drip Edge Metal - Choose one of the following: (For anti-ponding metal, see Section 3.12 C.2.c).

A. Single ply underlayment systems

1. Drip edge metal shall be installed at the eave, over the sheathing. The metal shall be fastened 6” on center with 12 ga. corrosion resistant roofing nails or fasteners of compatible metals. All joints shall be lapped a minimum of 2”. All metal laps shall be sealed.
2. Apply underlayments as per section 3.02 A or E for single ply underlayments.
or,

B. 2-ply underlayment systems

1. Drip edge metal shall be installed over base ply sheet, fastened 6” on center with 12 ga. corrosion resistant roof nails or fasteners. All joints shall be lapped a minimum of 2”.

3.04 Gable treatment - Choose one of the following:

A. Underlayment wrapped gable - Choose one of the following:

NOTE: Not recommended for flush finish. Rake tiles must be installed.

1. Extend underlayment beyond rake/gable end. Fold down onto fascia or barge board. Secure with nails and tin tags, round cap nails or other fasteners 6” on center.
or,
2. Trim underlayment at fascia or barge board. Install a peel and stick underlayment extending underlayment beyond rake/gable end. Fold down and seal onto fascia or barge board.

B. Metal Finish

1. Drip edge metal shall be installed at the gable, over the finished underlayment. The metal shall be fastened 6" on center with 12 ga. corrosion resistant roofing nails or fasteners of compatible metals. Continue from eave up rake/gable in same manner, ensuring water shedding capabilities of all metal laps. The cap sheet shall be bonded to the metal with asphaltic adhesive.

3.05 Valleys - Choose one of the following:

NOTE: Where special conditions exist, it may be necessary to increase the width of the valley.

NOTE: Closed valley metal shall be either a minimum width of 16" (24" stretch out) with a minimum 2 1/2" high center diverter and a minimum 1" metal edge returns or a ribbed design with 1" center diverter, a minimum four (4) 3/8" ribs spaced 3 1/2" with 3 3/4" flange.

A. Install preformed closed valley metal. Lap all joints a minimum of 6" and apply a coating or separator sheet. (See Drawing 3)

or,

B. Install preformed open valley with a minimum of 16" (24" stretch-out) with a minimum 1" high twin center diverter and minimum 1" metal edge returns. Lap joints a minimum 6" and apply a coating or separator sheet. (See Drawing 4).

For A or B: When using valley metal with returns,

1. Secure with clips fabricated from similar or compatible material. Clip 1" metal edge returns to either deck or batten strip with roofing nail through metal strap.
2. Trim metal at all valley/ridge junctions, ensuring water shedding capabilities onto the valley.
3. Install lead soaker at all valley/ridge junctions. Turn lead up a minimum of 1" to create a water diverter, ensuring water shedding capabilities onto the valley.
4. Outer edge of the valley metal shall overlap deck flange of drip edge a minimum of 1". Center of valley flashing shall extend a minimum of 2" beyond drip edge.

DRAWING 3

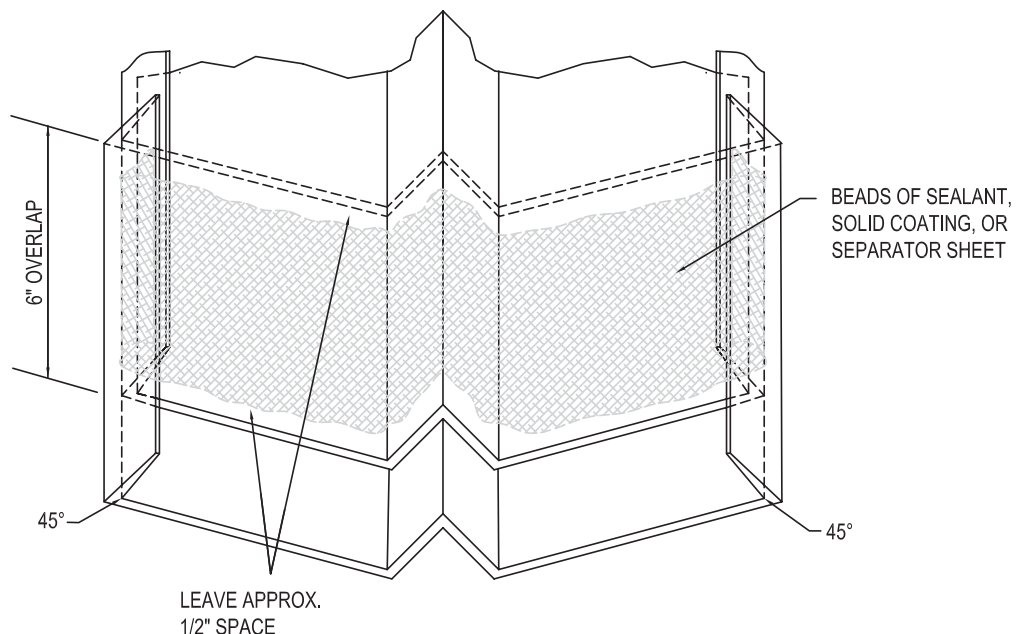

DRAWING 4

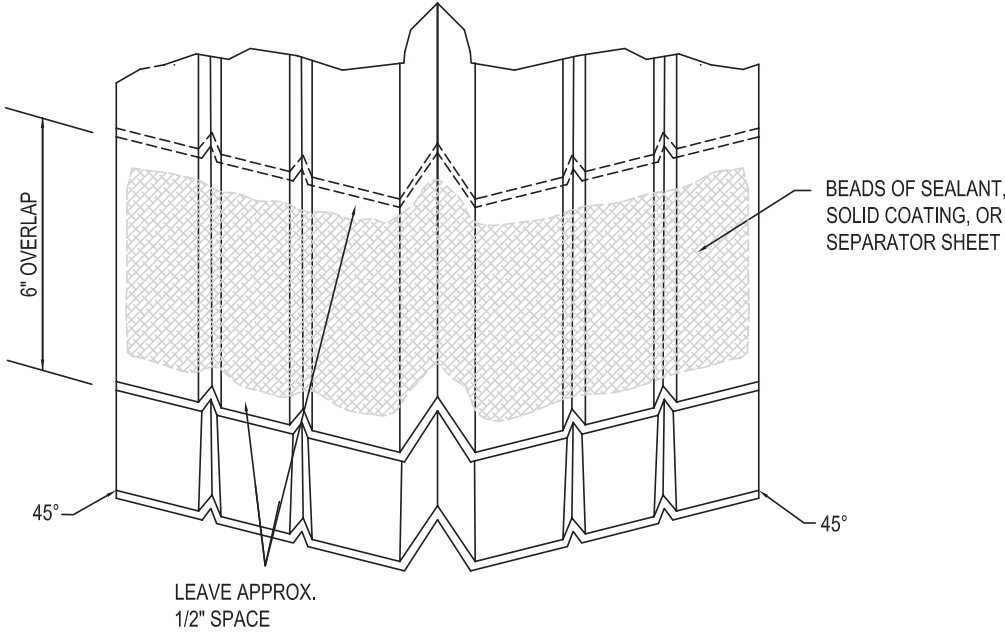

DRAWING 5

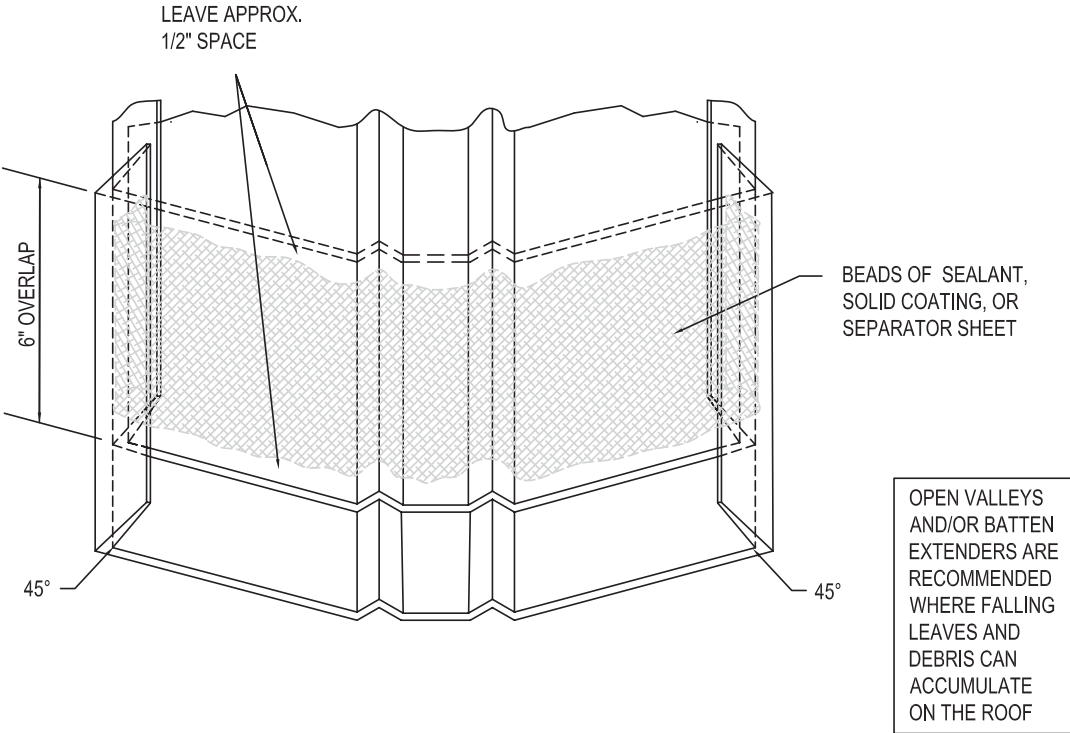

3.06 Valley or Wall Fastenings Termination onto Roof Plane

A. When valley terminates onto roof plane install in accordance with standard valley flashing procedures:

1. Apply a lead soaker/skirt underneath the eave end of valley or wall flashing to carry water off the valley or wall flashing back onto the field tile (See Drawing 6).
2. If lead skirt is not used, extend length of valley metal to carry water off the valley back onto the field tile.

DRAWING 6

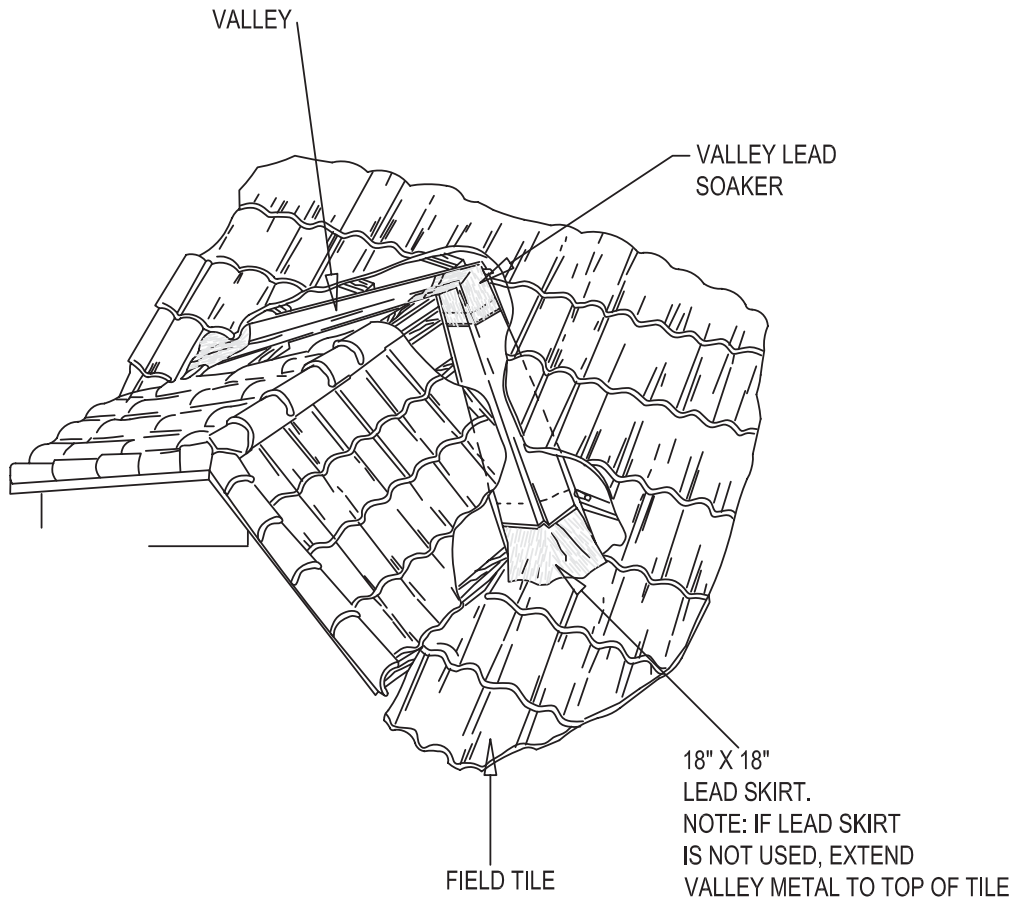

3.07 Flashing and Counterflashings at Wall Abutments (See Drawing 7)

- A. Install preformed metal wall tray 5" vertical flange, 6" base flange with 1" metal edge return flush to base of walls over underlayment. Start at lower portion and work up to ensure watertight application.
- B. Secure with clips fabricated from compatible material 24" on center. Clip 1" metal edge return to deck or batten strip with roofing nail through a metal strap.
- C. Nail vertical metal flange near outside edge. Secure as necessary to meet job conditions. Lap joints a minimum of 4" and apply flashing cement.
- D. On block walls, seal along entire edge of vertical metal flange, covering all nail penetrations with flashing cement and membrane.
- E. On frame walls, install vapor barrier over flashing.
- F. When installing optional counterflashing, lap top flange of base flashing a minimum of 2 1/2". Nail metal near the outside edge a minimum of 6" on center or set metal into reglets and seal thoroughly. Lap joints a minimum of 3".

DRAWING 7

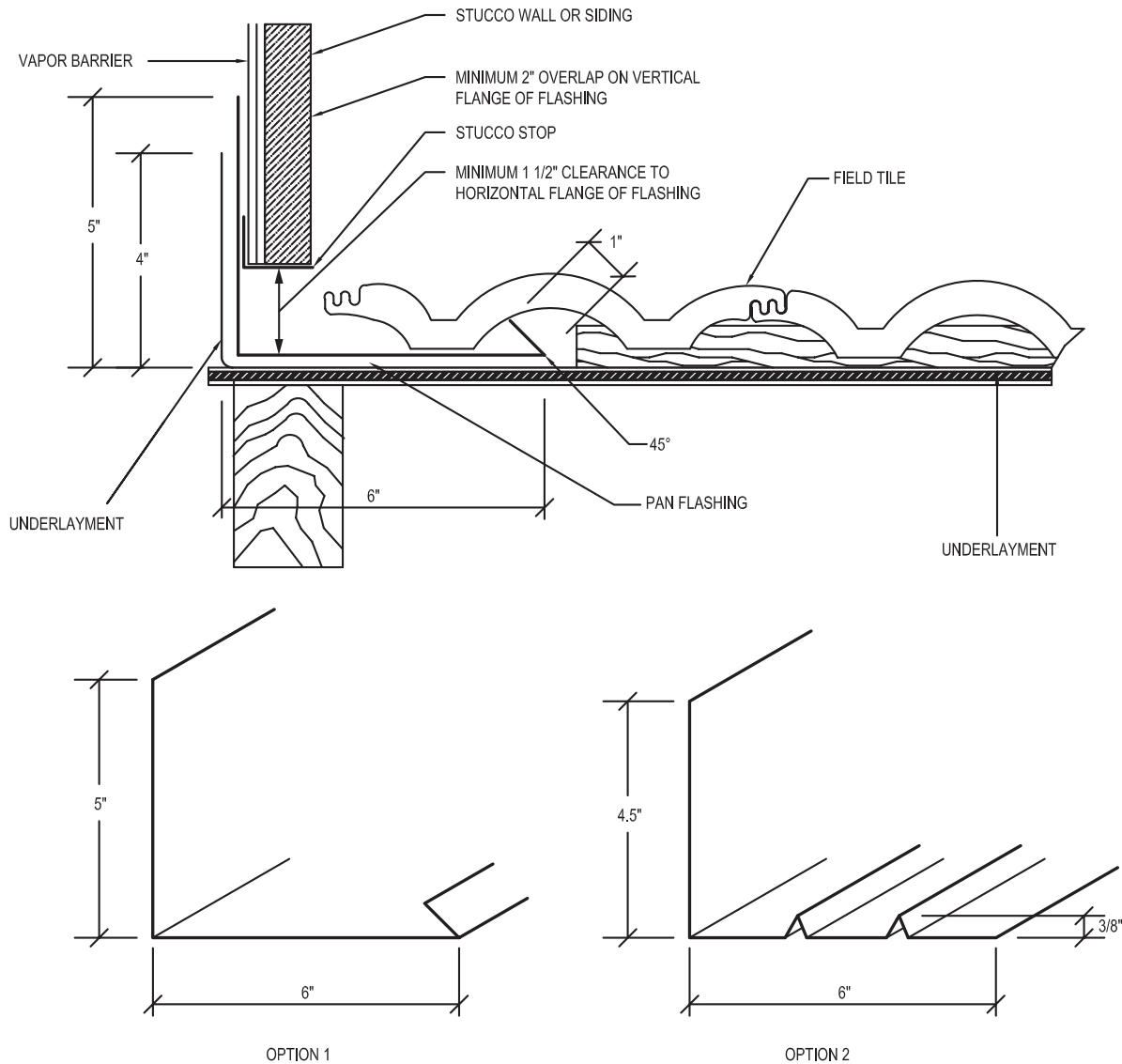

NOTE: THE FLASHING DIMENSIONS SHOWN ABOVE MAY VARY IN ACCORDANCE WITH THE BUILDING CODE, LOCAL BUILDER AND/OR SUB-CONTRACTOR PRACTICE AND LOCAL WEATHER CONDITIONS. ALL FLASHING MUST BE DESIGNED AND INSTALLED TO BE WATERTIGHT

NOTE: Where special conditions exist, it may be necessary to increase the width of the pan flashing. In all cases, flashing shall be designed to adequately direct water back onto the tiles.

3.08 Head & Apron Flashing (See Drawings 8, 9 & 10)

- A. Install apron flashing a minimum 4" on tile surface. Nail vertical flange of flashing within 1" of metal edge and secure as necessary.

DRAWING 8

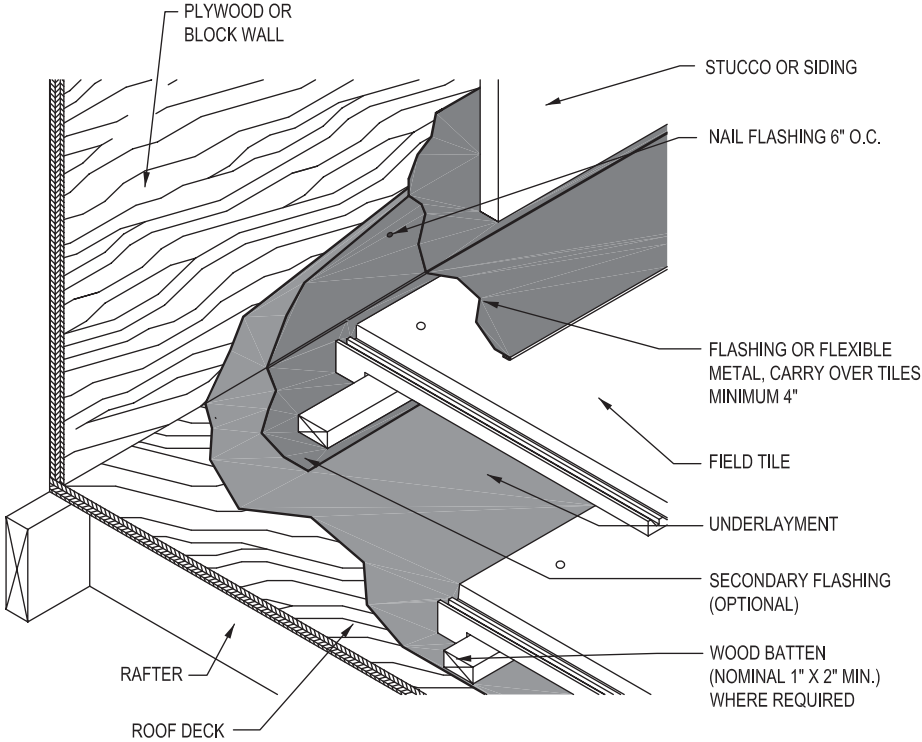

DRAWING 9

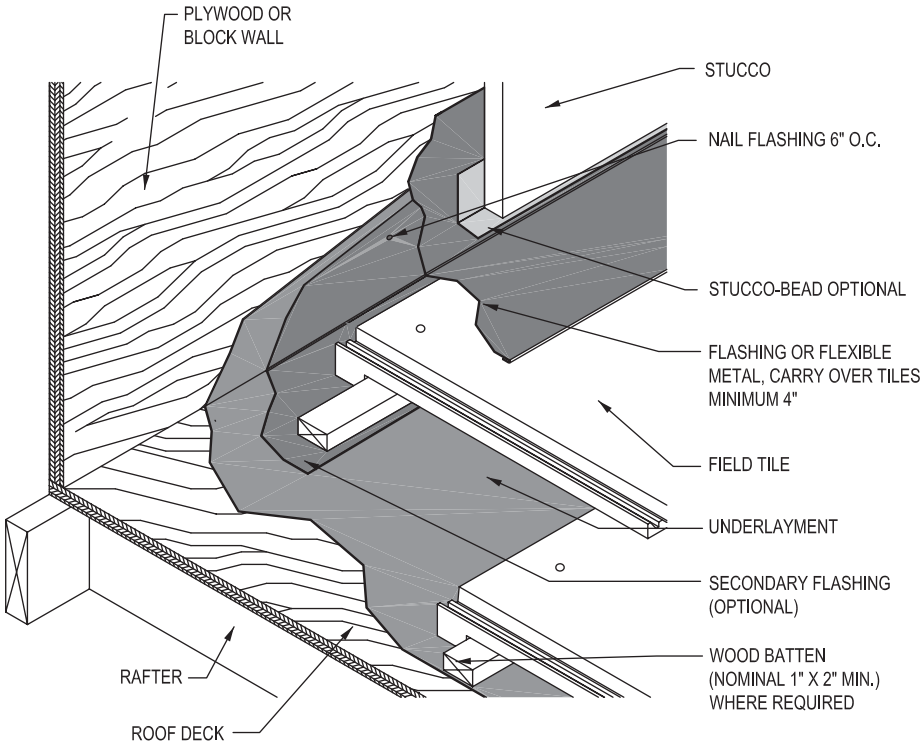

DRAWING 10

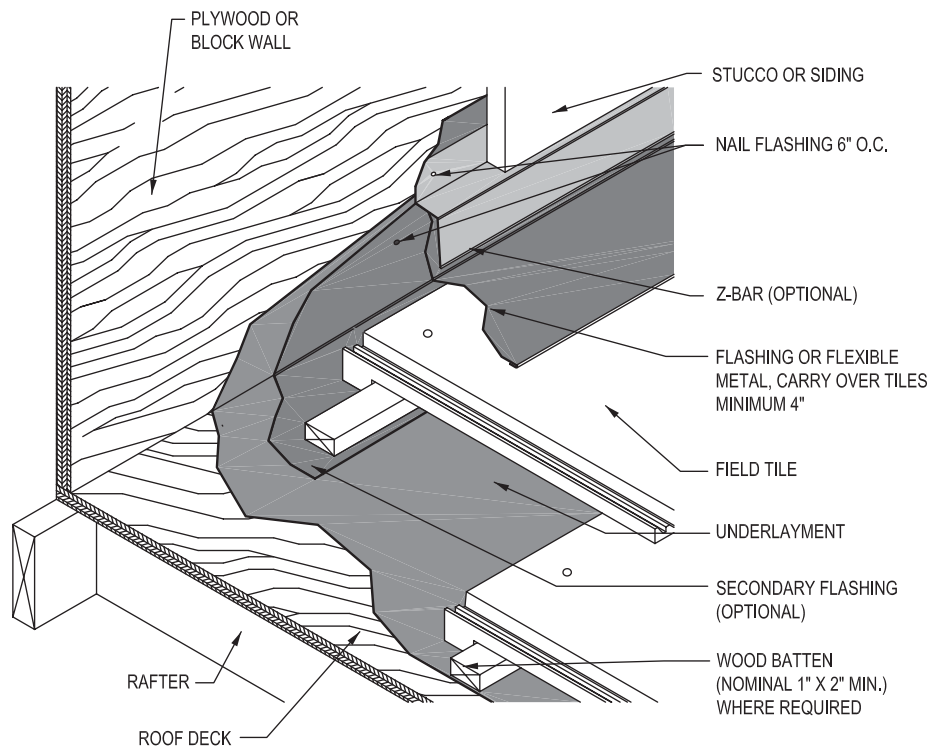

- 3.09 Standard Curb Mounted Skylights, Chimneys, Etc. (See Drawing 11)
- A. Curbs shall be a minimum nominal 2" x 6", and a minimum nominal 1 1/2" above tile height.
 - B. Install a minimum 12" width lead at eave end of each curb.
 - C. Secure with fasteners 6" on center, insuring fasteners will be covered by skylight/hood vent flange.
 - D. Continue with flexible or rigid flashing on both sides of the curb working up toward ridge. Trim as necessary to ensure water shedding onto field tile.
 - E. Secure with roofing fasteners 6" on center.
 - F. Install flexible or rigid flashing of sufficient width at ridge end of curb.
 - G. Seal all fasteners penetrations, at skylight or hood vent joints.
- NOTE:** For self curbing or prefabricated skylights, installation shall meet Section 3.09 above and skylight manufacturer's installation instructions.

DRAWING 11

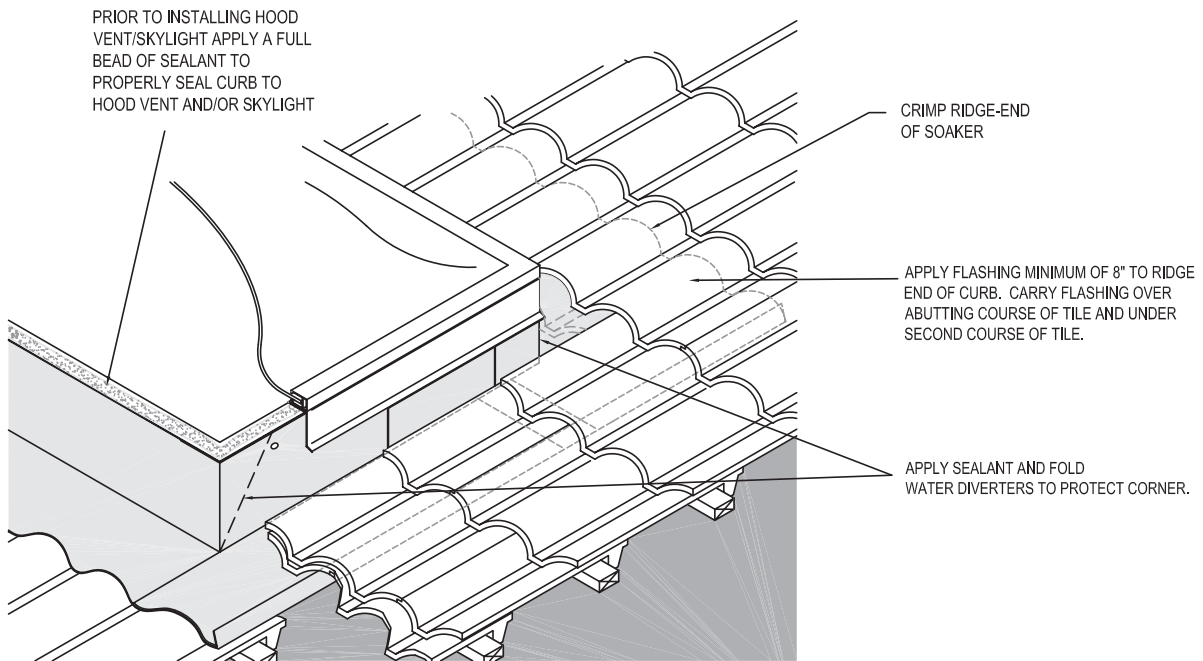

3.10 Pipes, Turbines, Vents, Etc. (See Drawings 12, 13 & 14)

A. Seal around penetration

B. Apply skirt flashing over last field tile cut previously installed extending under the course of tile above the penetration. Insure flashing is of sufficient width to redirect the water away from penetration.

C. Seal flashing to tile as needed.

NOTE: Profile specific ventilators should be installed as per manufacturer's installation instructions.

DRAWING 12

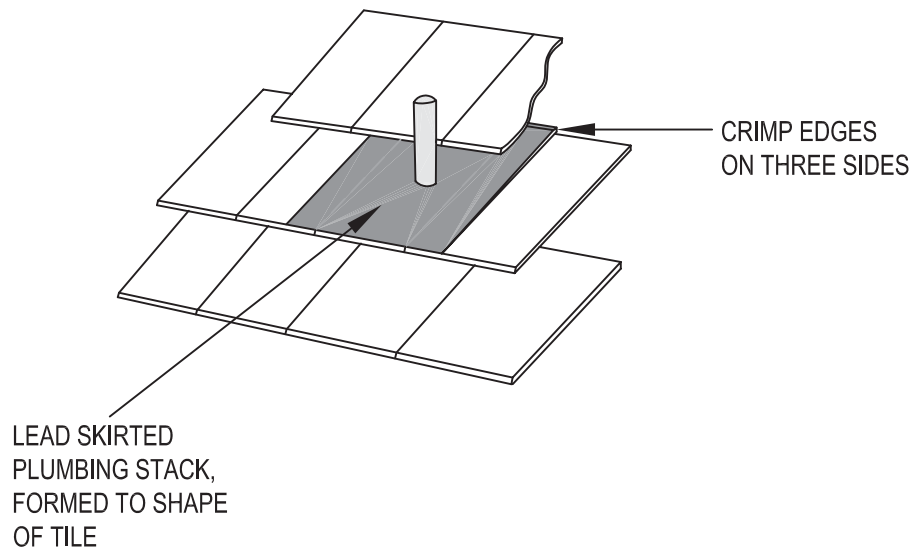

DRAWING 13

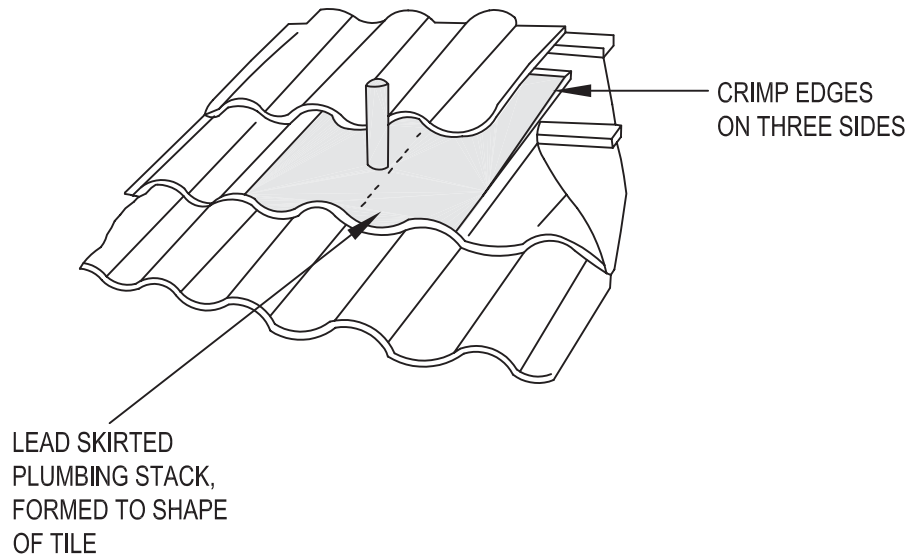

DRAWING 14

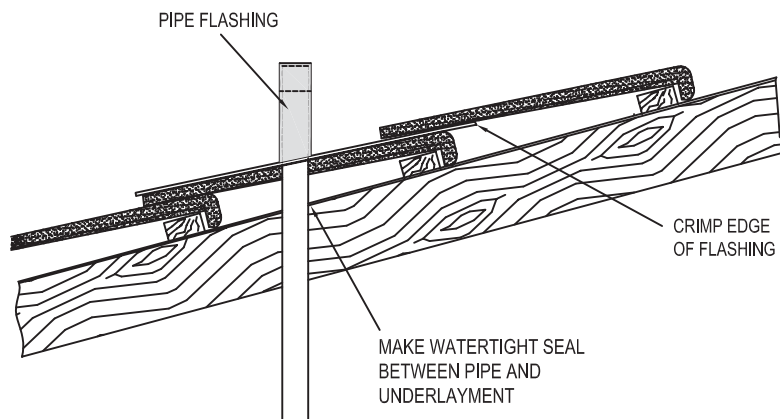

3.11 Batten Installation (See Drawing 15)

Horizontal battens shall be a maximum of 4' in length or batten material may be longer in length provided there are 1/2" weepholes every 4'.

- A. Install top edge of horizontal batten to horizontal line. Horizontal battens may be a minimum nominal 1"x 2".
- B. Fasten and secure maximum 24" on center with fasteners of sufficient length to penetrate the sheathing a minimum of 3/4".
- C. Leave 1/2" space between batten ends and between batten and metal edge returns.
- D. Fasteners shall be compatible with batten material.

DRAWING 15

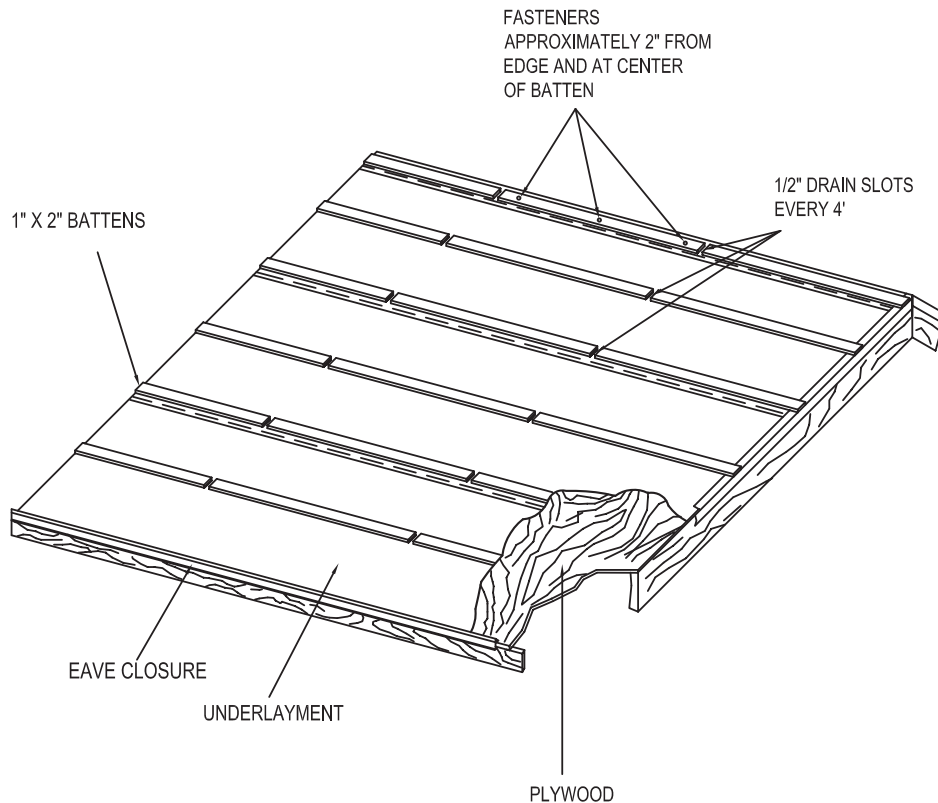

3.12 Tile Installation

A. Layout - Horizontal

1. Chalk horizontal lines beginning one tile length from eave less desired overhang. Overhang shall be 3/4" to 2", depending on tile type, use of gutter, or other functional requirements.
2. For batten installation only, chalk line approximately 1 1/2" from ridge.
3. Chalk succeeding lines for a minimum 3" headlap unless restricted by product design.
4. Increase headlap when necessary for equal course spacing, or as needed for unusual application conditions.

B. Layout - Vertical - Choose one of the following:

1. Staggered/cross bond tile installation (Required for flat tile)
 - a. Gable end roof
 - i. Chalk vertical lines one full tile and one half tile width plus 1" to 2" from starting gable to accommodate rake tile.
 - ii. Chalk additional lines, if necessary, to maintain alignment.
 - b. Hip roof
 - i. Chalk vertical line 90 degrees from eave line.
 - ii. Chalk second line parallel to first to accommodate staggered/cross bonded tile.
 - iii. Chalk additional lines, if necessary, to maintain alignment.
 or,
2. Straight bond tile installation
 - a. Gable end roof
 - i. Chalk vertical line one full tile width plus 1" to 2" from starting gable.

- ii. Chalk additional lines, if necessary, to maintain alignment.
 - b. Hip roof
 - i. Chalk vertical lines, if necessary, to maintain alignment.
 - ii. Chalk additional lines, if necessary, to maintain alignment.
 - C. Tile Installation
 - 1. Stack tile to facilitate installation and minimize tile movement.
 - 2. Eave treatment - Choose one of the following:
 - a. Prefabricated Rubber Eave Closure - Install closure strip along eave. Fasten with a minimum 3 fasteners per 36" strip (See Drawing 16) or,
 - b. Metal Eave Closure - Install closure strip along eave. Fasten a minimum 18" on center. If metal closure is inclusive of the drip edge fasten 6" on center (See Drawing 17) or,
 - c. Raised Fascia/Wood Starter Strip - (when using a 3/4" thick fascia, a nominal 2" x 2" wood starter strip must be installed behind fascia).
 - i. Install fascia board approximately 1 1/2" above roof deck or a nominal 2" x 2" wood starter strip at roof edge (See Drawing 18). Choose one of the following:
 - ii. Install 8" tapered cant strip at eave behind fascia and/or starter strip to support metal flashing when using drip edge. Tapered cant strip is optional when using anti-ponding metal or,
 - iii. Install a minimum 8" wide anti-ponding metal flashing to ensure positive drainage over fascia/starter strip. Nail top edge of flange onto roof.
 - iv. Apply underlayment as per Section 3.02.
 - d. Prefabricated concrete or clay eave closure- applied per manufacturer's specifications.
- NOTE:** Eave closure shall terminate at outer edge of valley and wall flashings.

DRAWING 16

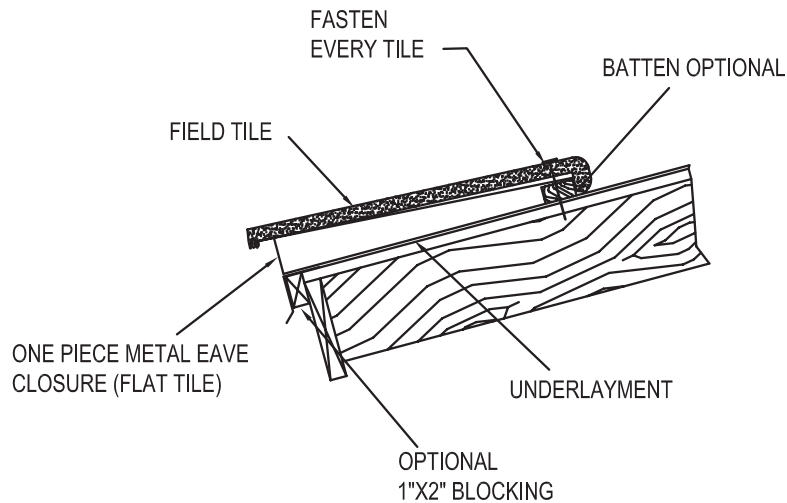

DRAWING 17

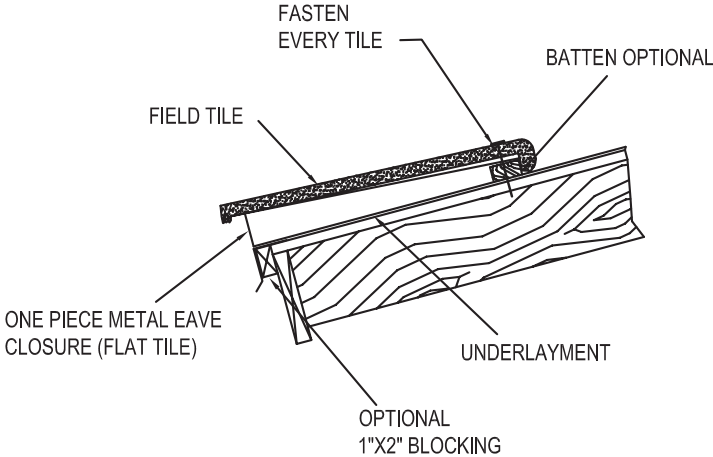

DRAWING 18

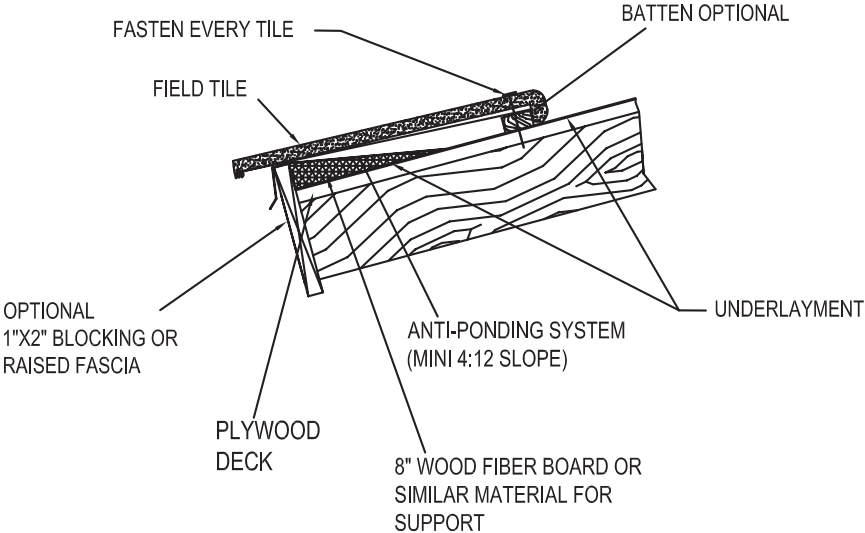

3.13 Flat/Low, Medium and High Profile Tile

- A. Install first course of tile, making certain all tile overhangs drip edge evenly along entire first course.
- B. Cut/break tile for proper staggering of tile courses when using the staggered/cross bond method of installation.
- C. Set tile in stepped course fashion or in a horizontal and/or vertical fashion when utilizing straight bond method.
- D. Lay succeeding courses of field tile in same manner.
- E. Secure tile with fasteners (see fastening chart).
- F. Cut/break field tile to form straight edge at center of hip/ridge.

NOTE: Tile shall be attached to resist the aerodynamic moment determined when using the design pressures for the building and the fixing calculations set forth in the building code.

3.14 Valleys - Choose one of the following:

NOTE: Outer edge of the valley metal shall overlap deck flange of drip edge a minimum of 1".
Center of valley flashing shall extend a minimum of 2" beyond drip edge.

NOTE: It is not recommended to install trim tile in valleys. It may be necessary to remove the lugs from the field tile and/or install batten extenders at wall and valley flashings for proper positioning of cut field tiles and to facilitate water flow.

A. Preformed Metal With 1" Returns

1. Closed Valley - Miter tile to form straight border on either side of water diverter (See Drawing 19).
2. Open Valley - Miter tile to form straight border on either side of two water diverters (See Drawing 20).

DRAWING 19

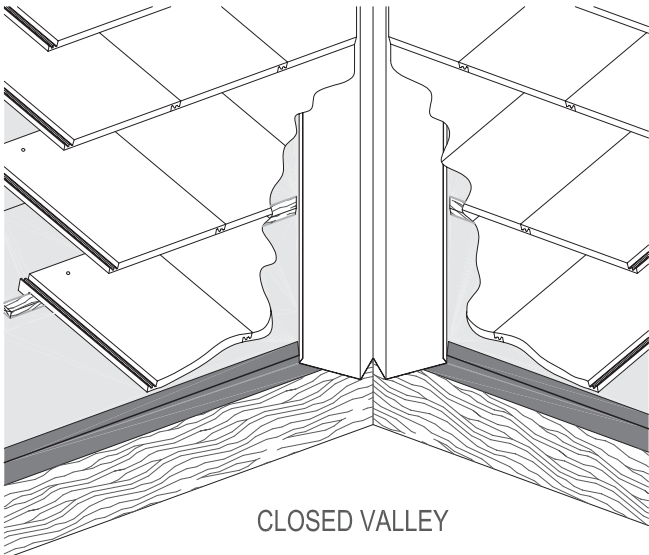

DRAWING 20

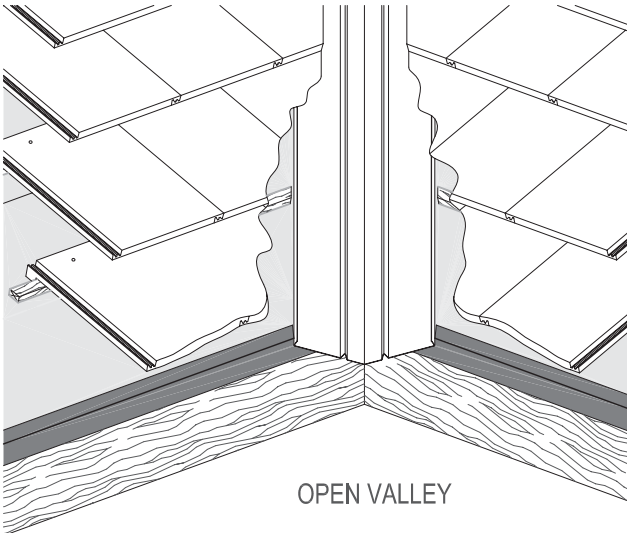

- 3.15 Hip Starter - Choose one of the following: (Refer to Instructions for Hip and Ridge Attachment)
- 3.16 Hip and Ridge Installation - (Refer to Instructions for Hip and Ridge Attachment)
- 3.17 Hip and Ridge Nailer Boards - (Refer to Instructions for Hip and Ridge Attachment)
- 3.18 Rake/Gable Tile - Choose one of the following:
- A. Rake/Gable Tile
 1. Install first rake tile to exposed length of first course of field tile with factory finish of rake tile towards the eave.
 2. Fasten rake tile with a minimum two 10D nails and/or of screws sufficient length to penetrate the framing a minimum of 3/4".
 3. Abut each succeeding rake tile to the nose of the field tile above and maintain a constant headlap.
 - B. Metal Finish
 1. Install prefabricated gable metal with 1" water return.
 2. Fasten by clipping 24" on center.
- NOTE:** Rake tile application at finishing end may need special consideration to provide proper drainage, i.e. flashing or sealant may be needed.
- 3.19 Wall Abutments
- A. Cut tile to fit approximately 1/2" to base of walls.
- NOTE:** It may be necessary to remove the lugs from the field tile and/or install batten extenders at wall and valley flashings for proper positioning of cut field tiles and to facilitate water flow.
- 3.20 Coatings - (optional)
- A. Sealer may be applied to exposed mortar.
 - B. Color coordinated paint may be applied to all metal flashings.
- 3.21 Tile Replacement
- A. Damaged Tile
 1. Break out and replace damaged roof tile. Do not disturb underlayment. Repair underlayment if necessary.
 2. Apply adhesive per adhesive manufacturer's recommendations.
 3. Immediately set replacement tile in position assuring proper contact.
 4. Removal of tile lugs is not recommended on batten systems.
 - B. Small Valley and Hip Cuts
 1. Elevate nose end of tile in course above small cut tile. Apply adhesive per adhesive manufacturer's recommendations.
 2. Immediately set tile in course above in position which assures proper contact.
- NOTE:** For hip cuts on roof slopes >7:12, mechanical fasteners may be required.
- 3.22 Clean-Up
- A. Remove all broken tile, debris and excess tile from roof.
- 3.23 Miscellaneous recommendations
- A. Instructions shall be given to all parties involved cautioning against traffic of any kind on finished roof. Damage to roof tiles and/or sub-roof may result.

FRSA & TRI MODEL TILE GUIDELINES

System Two

Mechanically Fastened Tile Guidelines

Sealed underlayment system using metal flashings without edge returns. Tiles are applied with mechanical fasteners direct to water-proofed deck.

DISCLAIMER NOTICE (PLEASE READ CAREFULLY):

These mechanically fastened tile guidelines are a consensus document developed by a joint Task Force of the Florida Roofing, Sheet Metal and Air Conditioning Contractors Association (FRSA) and the Florida Chapter of the Tile Roofing Institute (TRI). It is important to recognize that these recommendations are neither warranties, explicit or implicit, nor representative of the only method by which a mechanically fastened tile system can be installed. Rather, they try to summarize for the designer, applicator or developer good roofing practice and some of the industry standards for the installation of the mechanically-set tiles which have been developed over a period of time from actual trade practice and the requirements of various building code agencies. These guidelines may not be applicable in all geographical areas. **It is the responsibility of those individuals who are referring to these guidelines to independently research and determine which is best for their particular project.**

System Two

Mechanically Fastened Tile Guidelines

NOTE: The following table provides the contractor with the choices available for underlayment systems. These systems can only be used on pitches designated in the table below:

Slope of Roof	Direct Deck Only	Choice of Underlayments	Plastic or Compatible Cement at Fasteners Penetrating Underlayments	Reference
4":12" and greater	Direct Deck	1. Single-ply 90# Organic Cap Sheet or Modified Cap Sheet	Required	3.02 A
3":12" and greater	Direct Deck	2. Hot Mop Application - No.30 or No.43 / 90# Organic or Modified Cap Sheet	Required	3.02 B
3":12" and greater	Direct Deck	3. Cold Process Application - No.30 or No.43 / 90# Organic or Modified Sheet	Required	3.02 C
3":12" and greater	Direct Deck	4. Self Adhered Underlayment - Applied Direct to Wood Deck	See note below	3.02 D
3":12" and greater	Direct Deck	5. No.30/Self-Adhered Underlayment	See note below	3.02 E
As tested	Direct Deck	6. Alternative Membranes	See note below	3.02 F

Note: Refer to underlayment manufacturer's recommendations.

DIVISION 7

These guidelines cover Flat/Low, Medium and High Profile Roof Tile, using a minimum 3” tile headlap, or a designed limited headlap, on minimum 15/32” solid decking nailed in compliance with wind load requirements.

- 07300 - Shingles and Roofing Tiles
- 07320 - Roofing Tiles
 - Mechanically Fastened Tile Guidelines

PART I - GENERAL

- 1.01 Related Work Specified Elsewhere
 - A. Rough Carpentry - Section 06100
 - B. Roof and Deck Insulation - Section 07220
 - C. Flashing and Deck Insulation - Section 07600
 - D. Roof Accessories - Section 07700
- 1.02 Quality Assurance
 - A. Products
 - 1. Concrete Roof Tile - In compliance with the physical test requirements of the building code.
 - 2. Clay Roof Tile - In compliance with ASTM Standard C 1167.
 - B. Tile Attachment – Shall be in compliance with:
 - 1. ICC-SSTD-11
 - Or,
 - 2. TAS 101
- 1.03 Submittals
 - A. Samples - tile type and color as selected.
 - B. Manufacturer’s literature - including product descriptions and recommended installation procedures.
 - C. Tile Compliance Report.
- 1.04 Product Delivery, Storage and Handling
 - A. Distribute stacks of tile uniformly, not in concentrated loads.
 - B. When conditions warrant, install temporary battens to facilitate roof loading.
 - C. Care shall be taken to protect the underlayment during the tile loading and stacking process.
- 1.05 Job Conditions
 - A. Do not install underlayment or tiles on wet surfaces.
 - B. Ensure other trades are aware of precautions required when loading and stacking of tile, and their responsibility for protection of tile after loading and stacking is completed.
 - C. Any punctures or tears in the underlayment which occur during the loading and stacking of tile shall be immediately repaired with like materials.
- 1.06 Warranty
 - A. Materials - manufacturer’s limited warranty against defects in roof tile for ___ years.
(NOTE: Fill in appropriate number of years)

PART II - PRODUCTS

- 2.00 **DISCLAIMER NOTICE:** The FRSA and TRI rely on component industry data to establish minimum physical properties standards for their products. The standards listed in the Products section of this manual reflect that process.
- 2.01 Roof tile
- A. Tile Manufacturer: _____
 - B. Tile: _____
 - C. Approximate Weight: _____
- 2.02 Asphalt Saturated Roofing Underlayments
- A. Organic, type II, commonly called No. 30 or 30#, conforming to ASTM Standard D 226, type II organic saturated.
 - B. Asphalt - Saturated and Coated Organic Felt Base Sheet, commonly called No. 43 or 43#, per roll, conforming to ASTM D 2626.
 - C. Mineral surface roll roofing felt minimum 74 lbs. per roll commonly called 90#, conforming to ASTM D 249.
 - D. Modified bitumen single ply membrane minimum 40 mils.
 - E. Self-adhered membrane minimum 40 mils.
 - F. Granular surface SBS modified bitumen membrane, minimum 40 mils. at the selvage edge.
- 2.03 Membranes
- A. Organic - Asphalt impregnated cotton membrane, minimum 4" wide.
 - B. Inorganic - Asphalt impregnated fiberglass membrane, minimum 4" wide.
- 2.04 Fasteners
- A. Tile Fasteners
 - 1. Nails - corrosion resistant meeting ASTM A 641 Class 1 and/or corrosion resistance equal (according to ASTM B 117) of sufficient length to penetrate a minimum 3/4" into or through thickness of the deck.
 - a. Ring shank nails shall be 10d ring shank corrosion resistant steel nails (3 inches long, 0.283 inch flat head diameter, 0.121 inch shank diameter, 18-22 rings per inch).
 - 2. Screw Fasteners - corrosion resistant meeting ASTM A 641 Class 1 and/or corrosion resistance equal (according to ASTM B 117). Screws shall be 2 1/2" in length or penetrate a minimum 3/4" into the deck.
 - a. Minimum #8 course thread.
 - 3. Tile fasteners shall be compatible with batten material.
 - B. Underlayment Fasteners
 - 1. Nails or cap nails shall be of sufficient length to properly penetrate 3/4" into or through thickness of deck.
 - a. Minimum #11 gauge.
 - 2. Tin tags - not less than 1-5/8" nor greater than 2" in diameter and a minimum 32 gauge steel sheet metal.
 - a. Minimum #32 gauge sheet metal.
- 2.05 Metal Flashing
- A. Flashing shall be minimum 26 ga., G-90 corrosion resistant metal - conforming to ASTM A 525 and ASTM A 90, or other metal or composition profile materials as listed in the building code.
 - B. Lead for soil stacks shall be minimum 2.5 # per sq. ft. Lead weight flashing requirements follow the Lead Association recommendations.

- 2.06 Asphaltic Adhesive
 - A. Asphalt plastic roof cement - conforming to ASTM D 4586, type II, non-asbestos, non-running, heavy body material composed of asphalt and other mineral ingredients.
 - B. Cold process modified bitumen roofing mastic - conforming to ASTM D 3019, type III.
 - C. Asphalt - conforming to ASTM D 312, type III or IV (Note slope requirements in the building code).

- 2.07 Adhesive/Sealants
 - A. Structural bonding adhesive - conforming to ASTM D 3498.

- 2.08 Mortar
 - A. Materials
 - 1. Cement shall conform to ASTM C 91 Type M.
 - 2. Aggregates
 - a. Sand shall meet ASTM C 144, uniformly graded; clean and free from organic materials.
 - b. Lightweight aggregate shall meet ASTM C 332.
 - B. Mixes
 - 1. All mortar used to fasten field tiles shall be factory premixed and bagged and shall have a FBC (Florida Building Code) product approval.
 - 2. All mortar used to fasten hips and ridges shall, in addition to having a FBC product approval, be tested in accordance with ICC-SSTD-11 with data substantiating compliance.
 - 3. Job proportioned mixes (job site mortars) may be used for cosmetic purposes and for “wind block” only.

- 2.09 Eave Closure
 - A. Prefabricated EPDM synthetic rubber conforming to ASTM D 1056.
 - B. Prefabricated metal eave closure.
 - C. Prefabricated concrete or clay eave closure.
 - D. Mortar (color optional) on granular surface underlayments only.

- 2.10 Coating
 - A. Paint - color coordinated paint for painting tile, flashing and/or accessories (optional).
 - B. Sealer - for point-up mortar (optional).
 - C. Tint Seal - color coordinated sealer for staining tile or accessories (optional).

- 2.11 Sheathing - Material shall conform to APA rated sheathing.
NOTE: Refer to building code Wind Load requirements.
 - A. Minimum span rated 32/16; 15/32” thick APA rated sheathing.
 - B. Sheathing - Material shall conform to APA rated sheathing.
 - C. Nailer Boards - Material to be decay resistant or pressure treated in compliance with AWPI C2 or better.
 - 1. Nailer boards should not be bowed or twisted.
 - 2. Nailer boards shall be a nominal 2 inches x (sufficient height to satisfy conditions).

PART III - EXECUTION

3.01 Inspection

- A. Verify that surfaces to receive underlayments and roof tile are uniform, smooth, clean and dry.
- B. Proper ventilation is recommended on all tile applications. Verify ventilation requirements as set forth in the building code.

3.02 Underlayment Application - Choose one of the following:

NOTE: On cap sheet, cut fishmouths and seal with flashing cement and membrane where applicable.

NOTE: A No.15, No.30 or No.43 can be used as a dry in prior to installing the underlayment with this system (except on 3.02 D).

A. Single-ply 90# Organic Cap Sheet or Modified Cap Sheet (See Drawing 1)

A 90# organic cap sheet or modified cap sheet underlayment application can be installed with tiles applied direct to the cap sheet. Prior to applying the 90# or modified cap sheet, attach a 36" wide strip of same underlayment, (sweat sheet) down the center of the valley. Secure near the edge of the felt 24" on center. Apply a 90# or modified cap sheet perpendicular to the slope of the roof and mechanically attached to the wood deck with nails and tin caps, round cap nails or other fasteners spaced 12" on center near the top edge of felt. Use a minimum 4" head lap and 6" side laps. Overlap hip and ridges a minimum of 6". Seal all laps with compatible plastic cement.

DRAWING 1

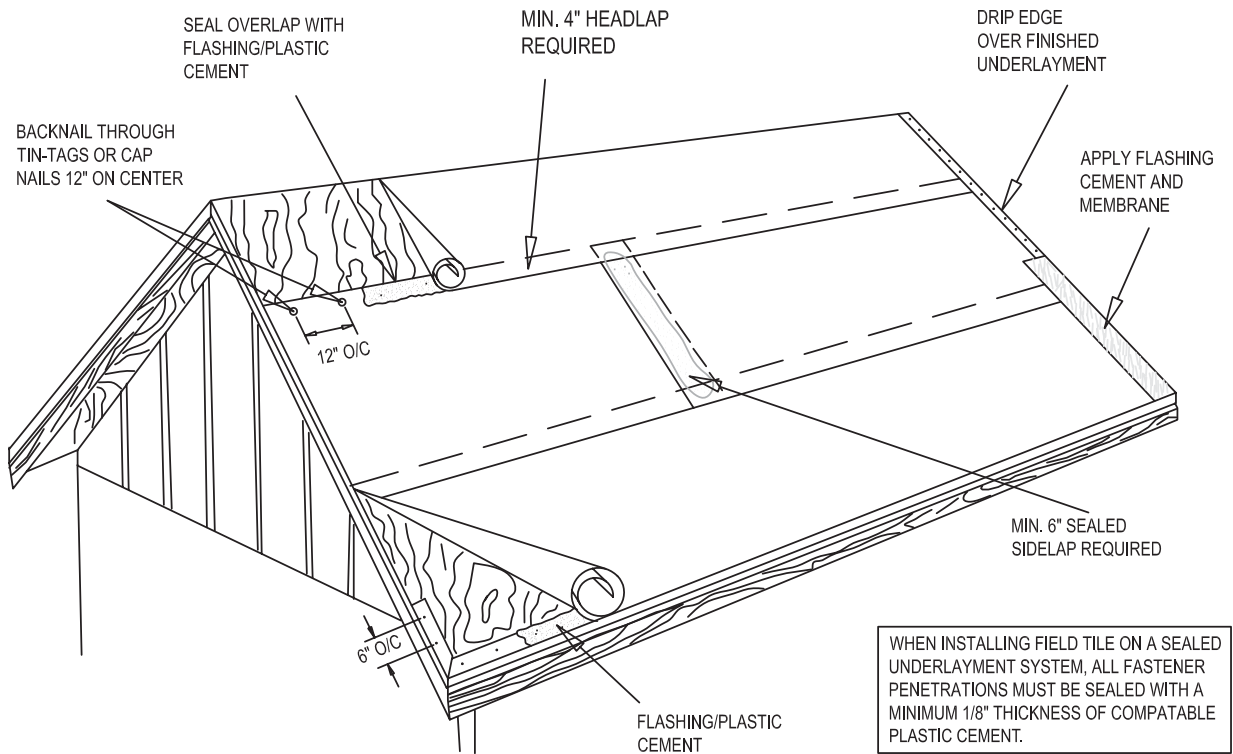

- B. Hot Mop Application - No.30 or No.43 / 90# Organic or Modified Cap Sheet (See Drawing 2)
 A two ply roof application commonly called a 'Hot Mop' system. The roof cover is terminated at metal flashings. A No.30 or No.43 base sheet shall be mechanically attached to the wood deck with nails and tin caps, round cap nails or other fasteners spaced in a 12" grid staggered in two rows in the field, and 6" on center at the laps. Extend base sheet a minimum of 4" up vertical surfaces. Base sheet side laps shall be a minimum of 6" and head laps shall be a minimum of 2". Over installed base sheet, apply the cap sheet in an application rate 25 #/sq. \pm 15% mopping of asphalt. With this system the cap sheet may come in contact with the base sheet, allowing felt to touch felt. Side laps shall be a minimum of 6"; head laps shall be a minimum of 3" and back nailed 12" on center.
- C. Cold Process Application - No.30 or No.43/90# Organic or Modified Cap Sheet (See Drawing 2)
 A two ply roof application commonly called a 'Cold Process' system. The roof cover is terminated at metal flashings. A No.30 or No.43 base ply sheet shall be mechanically attached to the wood deck with nails and tin caps, round cap nails or other fasteners spaced in a 12" grid staggered in two rows in the field, and 6" on center at the laps. Extend base ply sheet a minimum of 4" up vertical surfaces. Base ply side laps shall be a minimum of 6" and head laps shall be a minimum of 2". Over installed base sheet, apply a cap sheet according to underlayment/adhesive manufacturer recommendations. Cap sheet side laps shall be a minimum of 6"; head laps shall be a minimum of 3" and back nailed 12" on center.
- NOTE:** For Cold Process-Systems, in windy conditions, it may be necessary to spot nail cap sheet laps at a maximum of 3' on center.

DRAWING 2

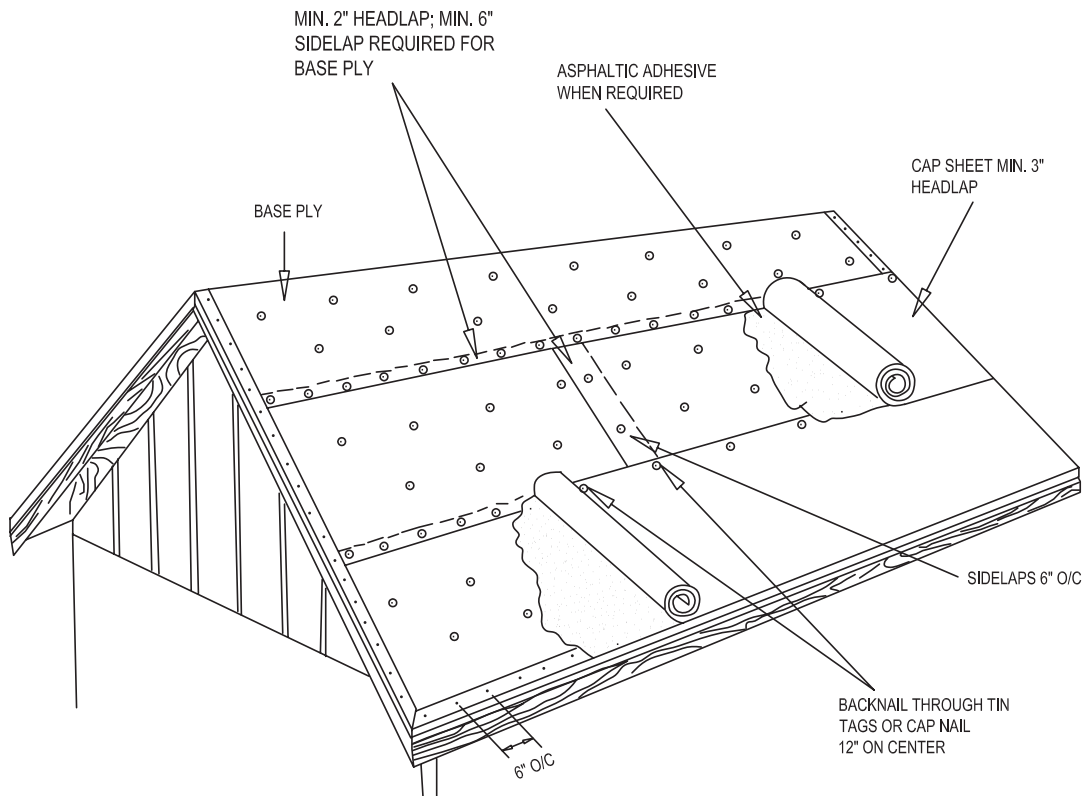

D. Self-Adhered Underlayment - Applied Direct to Wood Deck.

A single ply underlayment system utilizing self-adhered underlayment. Apply one layer of self-adhered underlayment in compliance with the self-adhered underlayment manufacturers' recommendations.

E. No.30/Self-Adhered Underlayment

A two ply roof application utilizing a self-adhered underlayment. A No.30 felt shall be mechanically attached to the wood deck with nails and tin caps, round cap nails or other fasteners spaced in a 12" grid staggered in two rows in the field, and 6" on center at the laps. Extend base ply a minimum of 4" up vertical surfaces. Anchor sheet side laps shall be a minimum of 6" and head laps shall be a minimum of 2". Over installed base ply, apply one layer of self-adhered underlayment in compliance with the self-adhered underlayment manufacturers' recommendation.

F. Alternative Membranes

Any product consisting of one or more water shedding layers applied to a sloped roof prior to the application of a prepared roof covering having been tested in compliance with the building code. The primary purpose of an underlayment is defined as a water shedding layer to function in combination with a prepared roof covering.

3.03 Drip Edge Metal - Choose one of the following:

(For anti-ponding metal, see Section 3.08 C.2.c)

A. Single ply underlayment systems

1. Drip edge metal shall be installed at the eave, over the sheathing. The metal shall be fastened 6" on center with 12 ga. corrosion resistant roofing nails or fasteners of compatible metals. All joints shall be lapped a minimum of 2". The metal shall be coated with a bed of flashing cement.
2. Apply underlayments as per section 3.02 A for single ply underlayments.
3. Continue from eave up rake/gable in same manner, ensuring watershedding capabilities of all metal laps. On gable, the metal and underlayments sheet shall be joined with a bed of flashing cement, and a 4" strip of asphalt saturated cotton or fiberglass fabric. The fabric shall be fully embedded in the flashing cement.

or,

B. 2-ply underlayment systems

1. Edge metal shall be installed over the anchor sheet at all perimeters fastened 6" on center with 12 ga. corrosion resistant roof nails or other fasteners. All joints shall be lapped a minimum of 2". Continue from eave up rake/gable in same manner, ensuring watershedding capabilities of all metal laps. The cap sheet shall be bonded to the metal with asphaltic adhesive.
- or,
2. Drip edge metal shall be installed at the eave over the finished cap sheet. The metal shall be fastened 6" on center with 12 ga. corrosion resistant roofing nails, or other fasteners. All joints shall be lapped a minimum of 2". The metal and cap sheet shall be joined with a bed of flashing cement and a 4" strip of asphalt saturated cotton or fiberglass fabric. The fabric shall be fully embedded in the flashing cement.

3.04 Valleys - Choose one of the following: (See drawings 3, 4 & 5)

A. Two Ply System - Choose one of the following:

1. Standard Roll Metal - minimum 16" wide, shall be placed over the anchor sheet in the valley and shall be fastened 6" on center with 12 gauge corrosion resistant roofing nails, or other fasteners of compatible metals near the outside edge of the valley metal. All joints shall be lapped a minimum of 6" in a bed of flashing cement. The cap sheet shall be bonded to the metal with asphaltic adhesive (See Drawing 6).
- or,
2. Preformed metal without returns - minimum 16" wide, shall be placed over the anchor sheet in the valley and shall fastened 6" on center with 12 gauge corrosion resistant roofing nails, or other fasteners of compatible metals near the outside edge of the valley metal. All joints shall be lapped a minimum of 6" in a bed of flashing cement. The cap sheet shall be bonded to the metal with asphaltic adhesive (See Drawings 7).

DRAWING 3

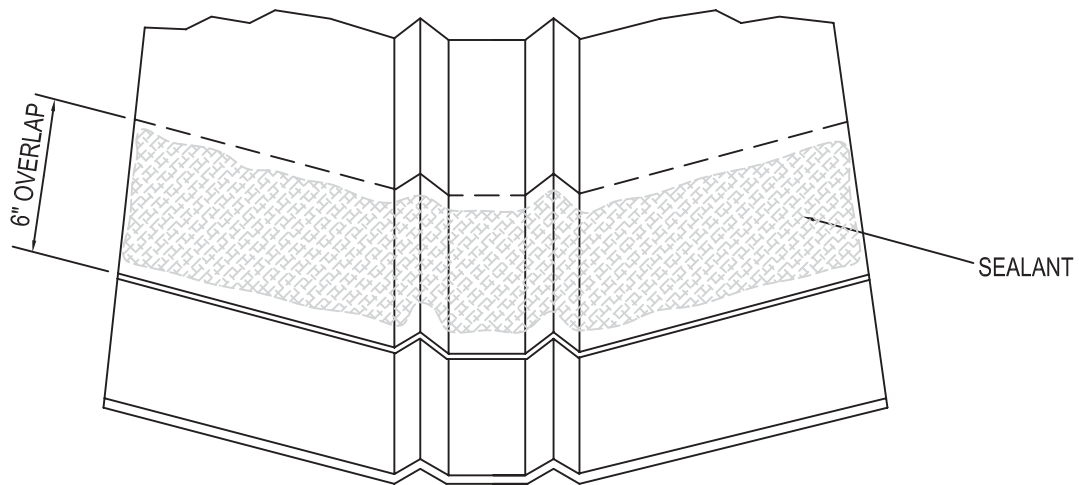

DRAWING 4

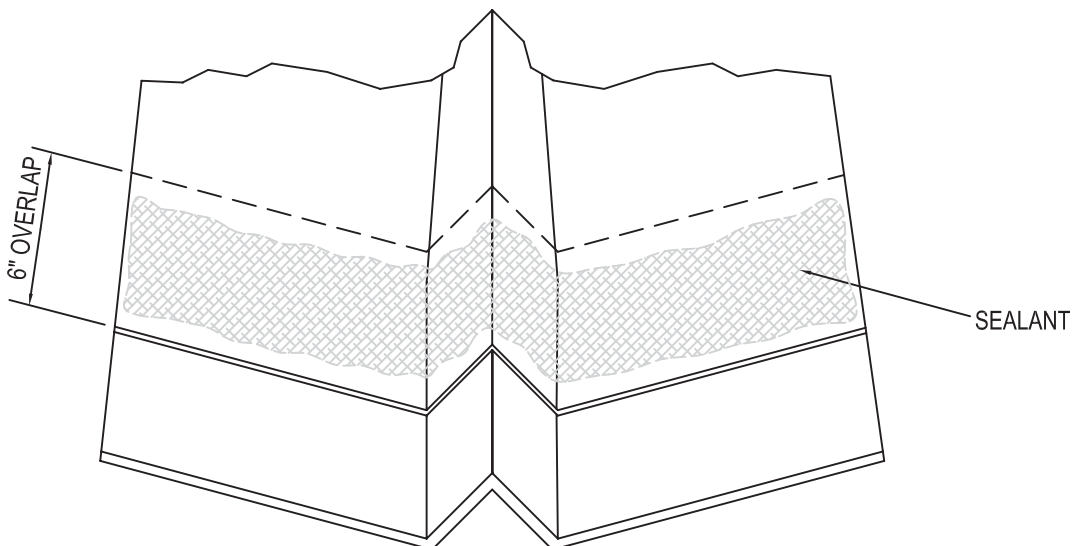

DRAWING 5

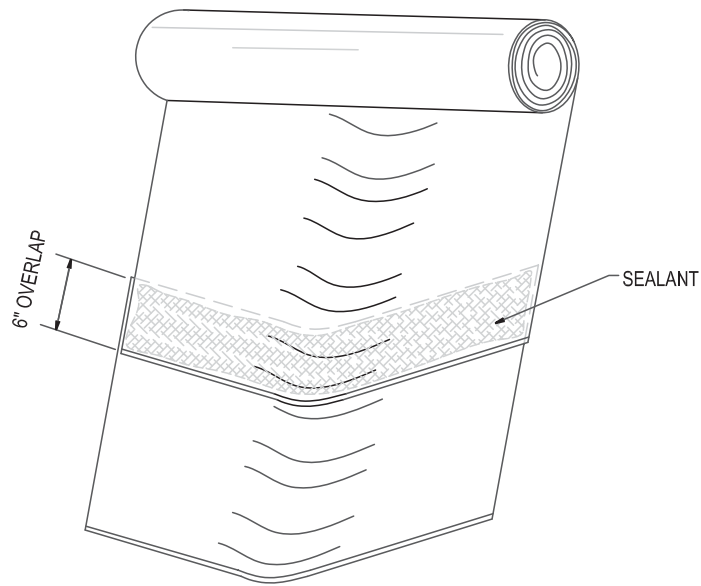

B. Over Cap Sheet - Choose one of the following:

1. Standard Roll Metal - minimum 16" wide shall be placed over the cap sheet in the valley and shall be fastened 6" on center with 12 gauge corrosion resistant roofing nails, or other fasteners of compatible metals near the outside edge of the valley metal. All joints shall be lapped a minimum of 6" in a bed of flashing cement. The cap sheet shall be joined with a bed of flashing cement and a 4" strip of asphalt saturated cotton or fiberglass fabric. The fabric shall be fully embedded in the flashing cement.

or,

2. Preformed Metal Without Returns -minimum 16" wide shall be placed over the anchor sheet in the valley and shall be fastened 6" on center with 12 gauge corrosion resistant roofing nails, or other fasteners of compatible metals near the outside edge of the valley metal. All joints shall be lapped a minimum of 6" in a bed of flashing cement. The cap sheet shall be joined with a bed of flashing cement and a 4" strip of asphalt saturated cotton or fiberglass fabric. The fabric shall be fully embedded in the flashing cement.

DRAWING 6

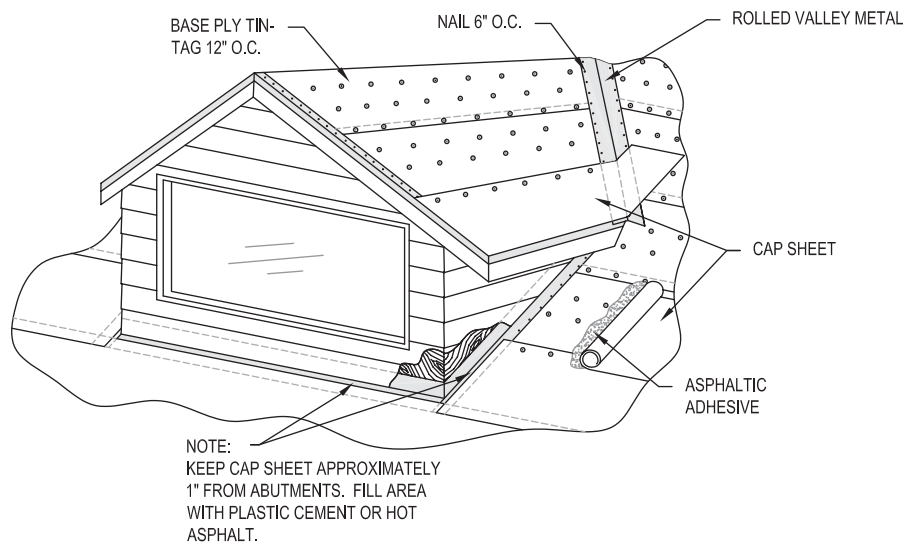

DRAWING 7

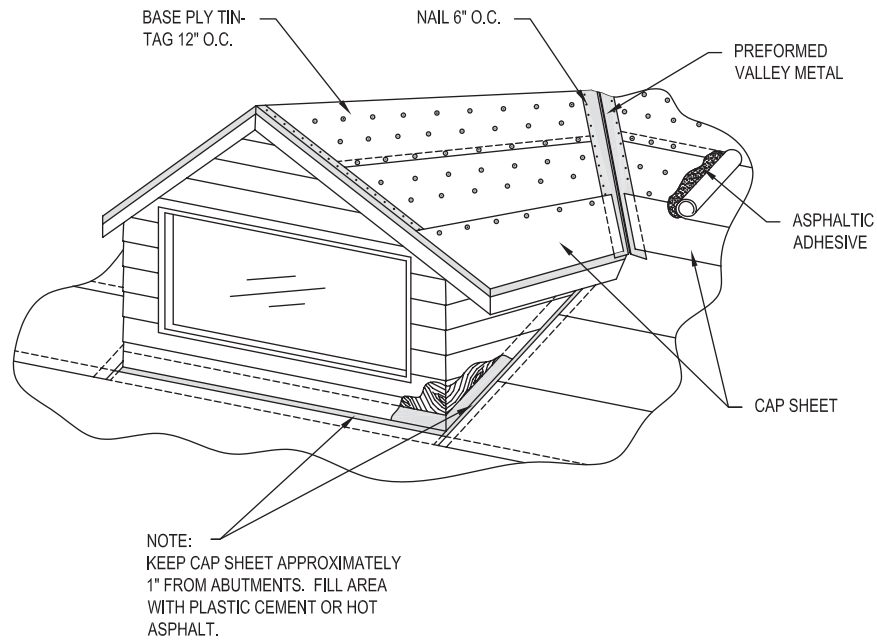

DRAWING 8

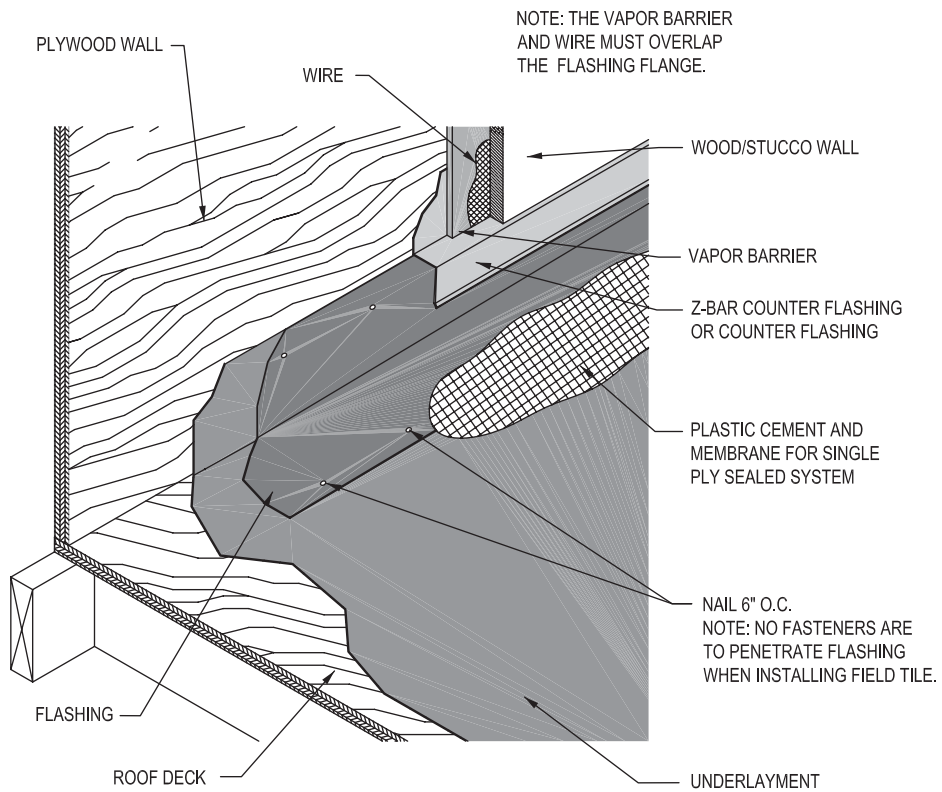

DRAWING 9

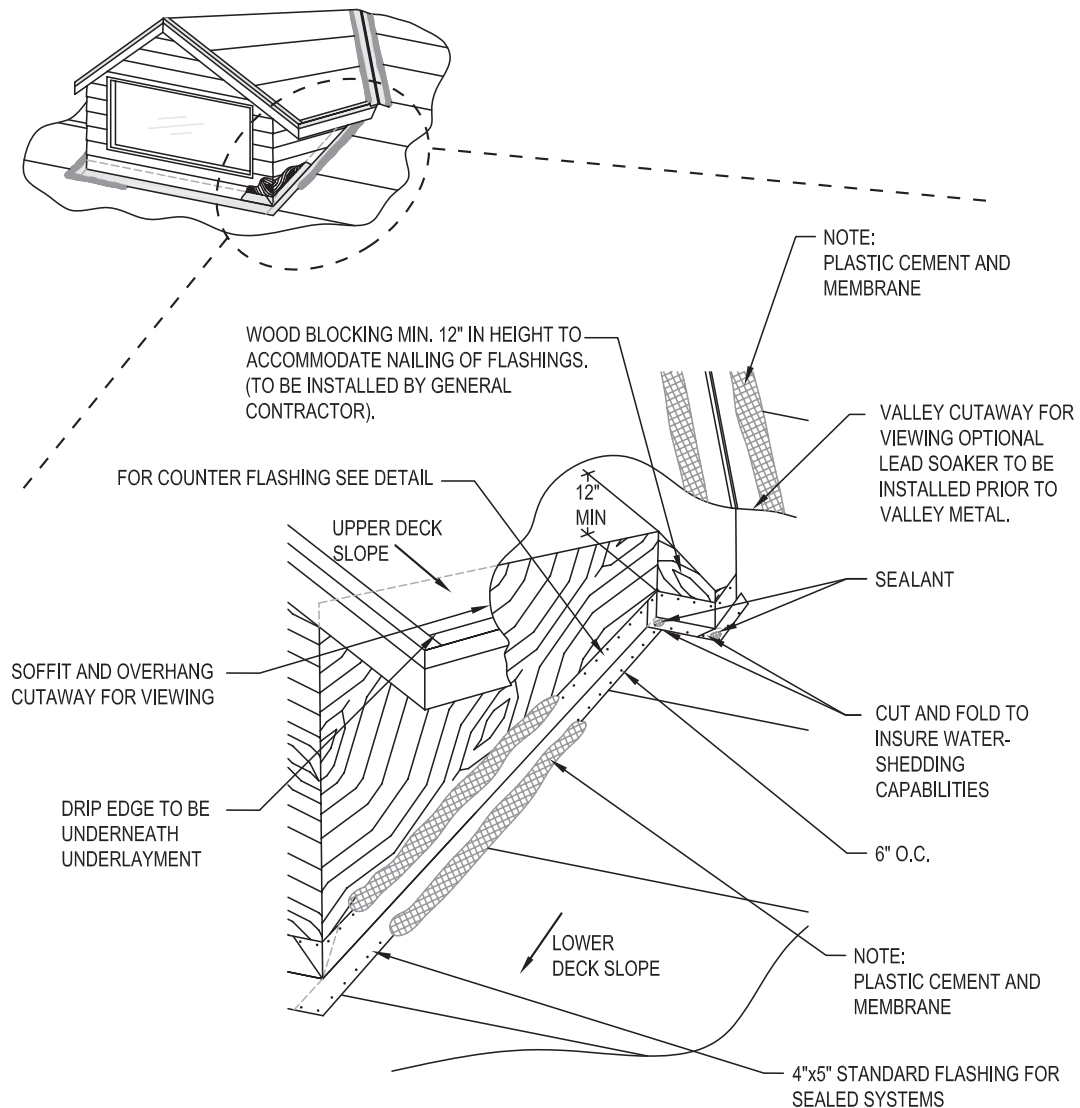

3.05 Flashing and Counter Flashings at Wall Abutments

A. Single Ply System (See Drawing 8 and 9)

1. Install 4" x 5" "L" flashing flush to base of walls with 4" flange on single ply underlayment and nail near the metals edge. Lap joints 4" and apply flashing cement between laps. Start at lower portion and work up to ensure water tightness. Nail 6" on center near the edge of the metal.
2. On block walls, seal along top edge of vertical flange, covering all nail penetrations with flashing cement and membrane where required.
3. When installing optional counter flashing, lap top flange of base flashing a minimum of 2 1/2". Nail metal near the outside edge a minimum of 6" on center or set metal into reglets and seal thoroughly. Lap joints a minimum of 4" and apply flashing cement or sealant between the laps.
4. On frame walls, install vapor barrier over flashing.
5. All head/apron flashing shall be installed on top of cap sheet (See Drawing 9). Ensure the deck flange conforms to the pitch of the roof and extend minimum 4" onto deck. Seal along edge with flashing cement and membrane.

- B. Two Ply System - (Choose 1 or 2) (See Drawings 6 and 7 or 10 and 11).
1. Install 4" x 5" "L" flashing flush to base of walls with 4" flange on the anchor sheet and nail near the metals edge. Lap joints 4" and apply flashing cement between laps. Start at lower portion and work up to ensure water tightness. Fastened 6" on center near the edge of the metal. The cap sheet shall be bonded to the metal with asphaltic adhesive.
or,

DRAWING 10

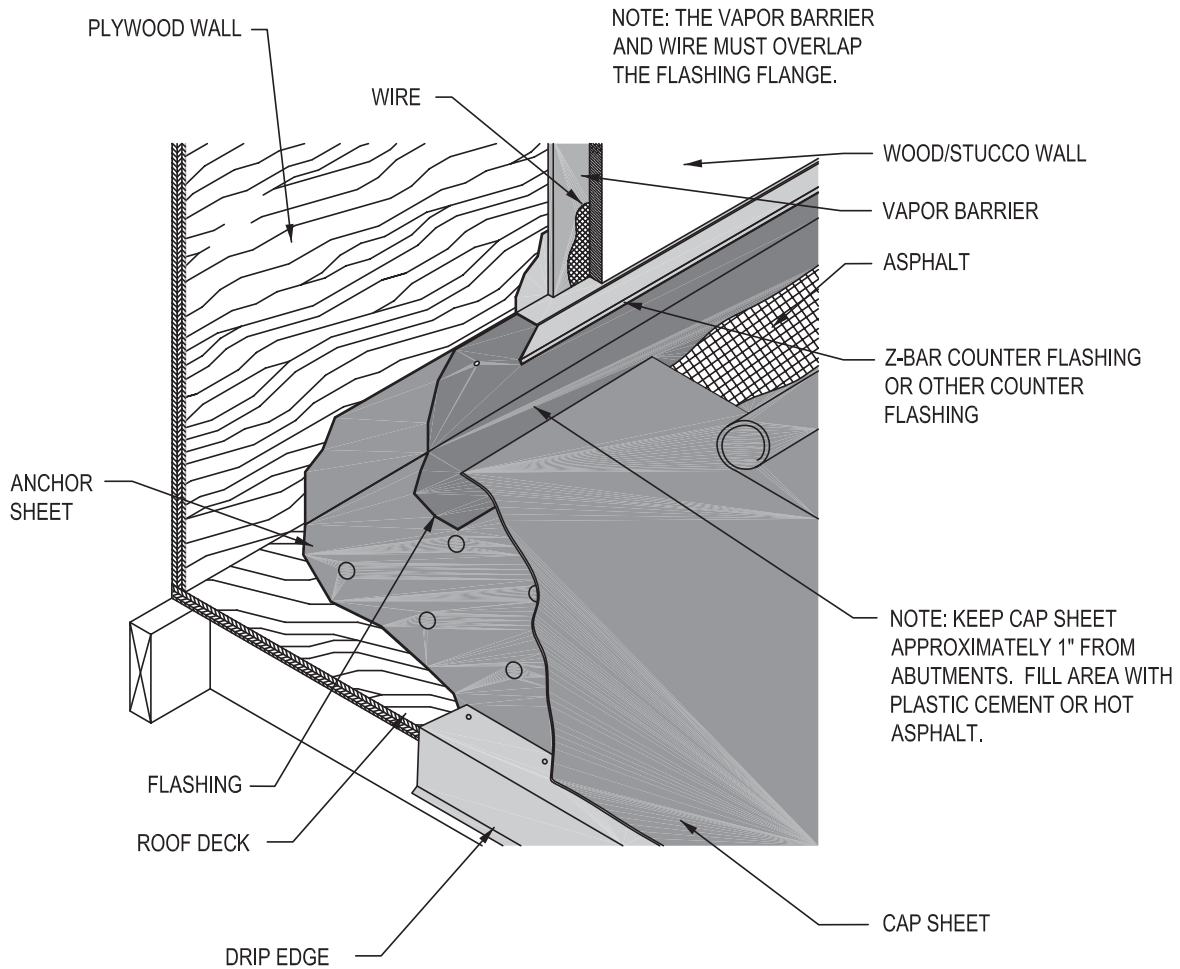

DRAWING 11

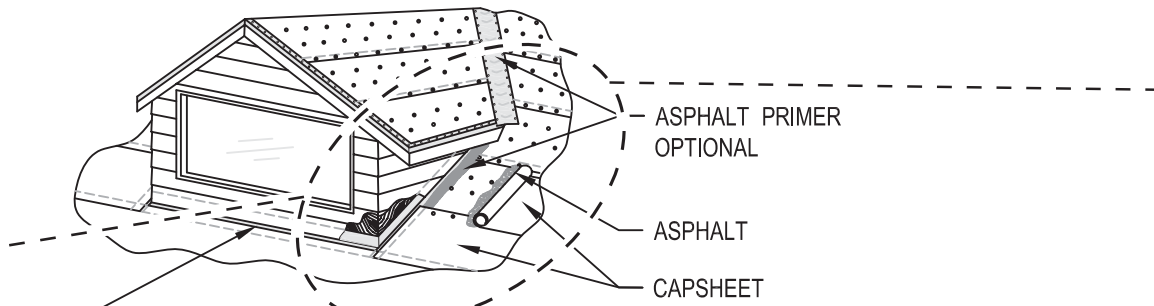

NOTE:
KEEP CAP SHEET APPROXIMATELY 1" FROM ABUTMENTS.
FILL AREA WITH PLASTIC CEMENT, HOT ASPHALT, OR PLASTIC CEMENT AND MEMBRANE.

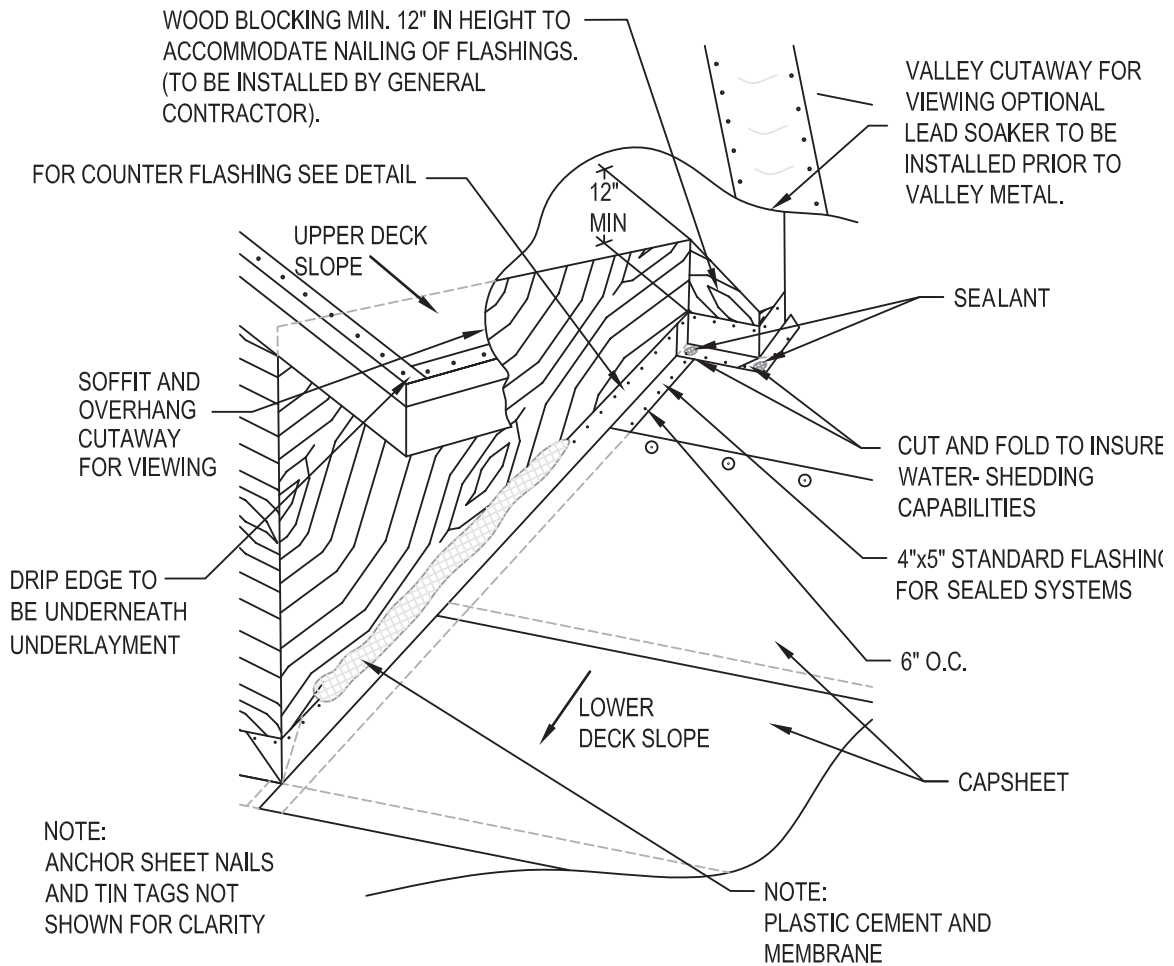

2. Install 4" x 5" "L" flashing on the cap sheet and fasten 6" on center with 12 ga. corrosion resistant roof nails, or other fasteners of compatible metals near the outside edge of the metal. All joints shall be lapped a minimum of 4" and apply plastic cement between laps. Cap sheet shall be joined to the "L" flashing with flashing cement and a 4" strip of asphalt saturated cotton or fiberglass fabric. The fabric shall be fully embedded in the flashing cement.
3. Seal along top edge of vertical flange, covering all nail penetrations with flashing cement and membrane where required.
4. When installing optional counter flashing, lap top flange of base flashing minimum 3". Nail metal near the outside edge a minimum of 6" on center or set into reglets (secured properly) and thoroughly caulk. Lap joints minimum 3" and apply flashing cement between laps.

3.06 Standard Curb Mounted Skylights, Chimneys, Etc. (See 3.05)

A. Install in compliance with regular flashing installation procedures.

NOTE: For self curbing or prefabricated skylights, refer to skylight manufacturer's installation instructions.

3.07 Pipes, Turbines, Vents, Etc. (See Drawings 12 & 13)

A. Apply flashing cement around base of protrusion and on the bottom side of metal flanges sealing unit base flashing to deck.

B. Nail and secure all sides of base flashing near the edge. Make certain base is flush to deck.

NOTE 1: If pipes, vents and/or turbines are installed after finished cap sheet has been applied follow instructions in 3.07 A & B. Cap sheet and metal flange shall be joined with a bed of flashing cement and a strip of asphalt saturated cotton or fiberglass fabric. The fabric shall be fully embedded in the flashing cement.

NOTE 2: Profile specific ventilators should be installed as per manufacturer's installation instructions.

DRAWING 12

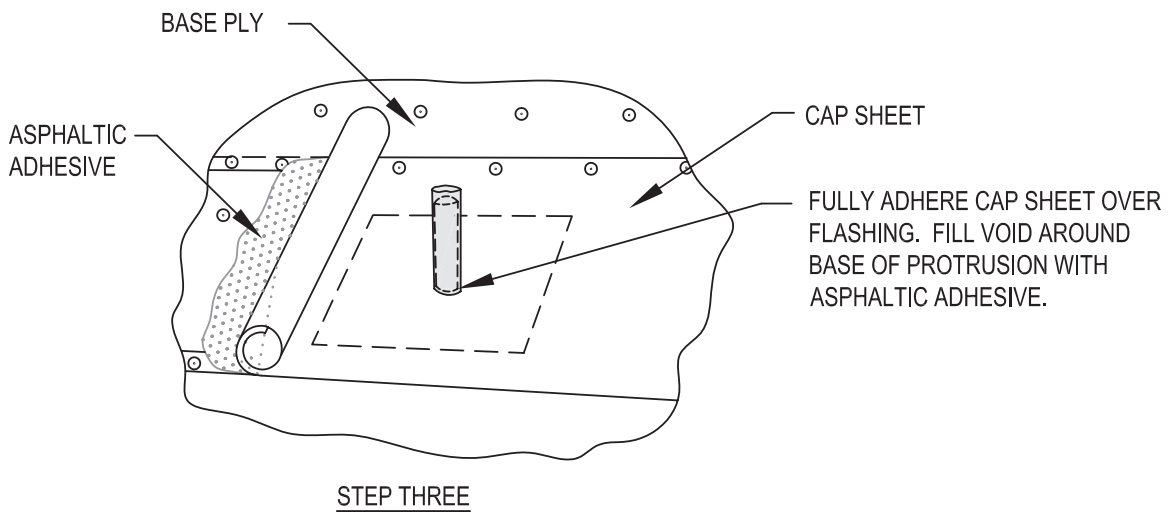
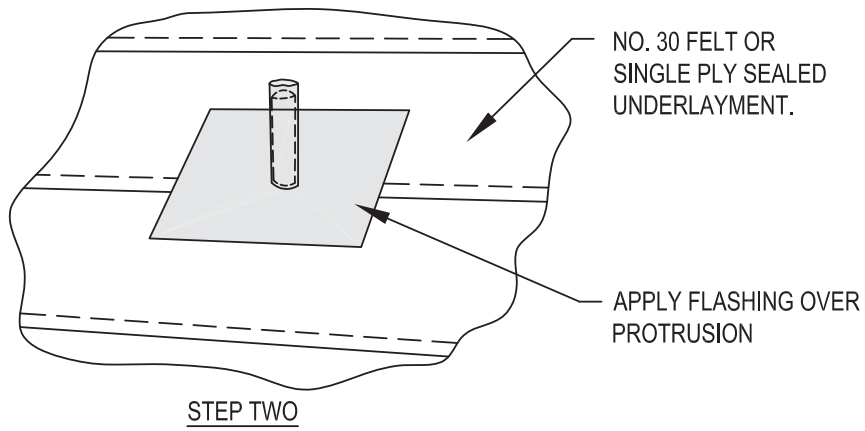
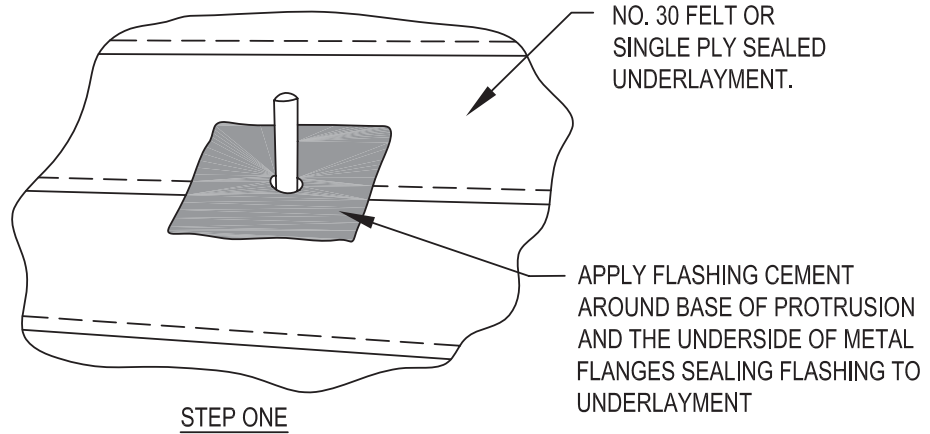

DRAWING 13

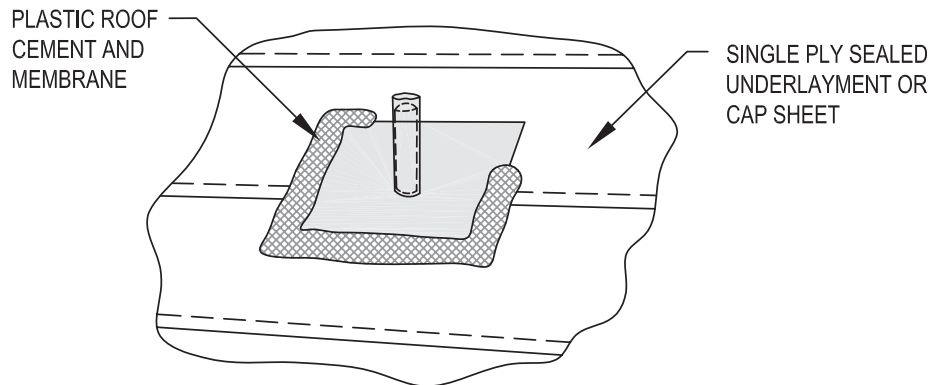

APPLY FLASHING CEMENT AROUND BASE OF PROTRUSION AND UNDERSIDE OF METAL FLANGES. SEAL ALONG EDGE OF METAL FLANGES, COVERING ALL NAIL PENETRATIONS WITH PLASTIC ROOF CEMENT AND MEMBRANE.

3.08 Tile Installation

A. Layout - Horizontal

1. Chalk horizontal lines beginning one tile length from eave less desired overhang. Overhang shall be 3/4" to 2", depending on tile type, use of gutter or other functional requirements.
2. Chalk succeeding lines for a minimum 3" headlap unless restricted by product design.
3. Increase headlap when necessary for equal course spacing, or as needed for unusual application conditions.

B. Layout - Vertical - Choose one of the following:

1. Staggered/cross bond tile installation -
 - a. Gable end - Choose one of the following:
 - i. Chalk vertical lines one full tile and one half tile width plus 1" to 2" from starting gable to accommodate rake tile.
 - or,
 - ii. Chalk vertical lines one full tile and one half tile width plus 1/4" from starting gable to accommodate flush finish.
 - iii. Chalk additional lines, if necessary, to maintain alignment.
 - b. Hip roof
 - i. Chalk vertical line 90 degrees from eave line.
 - ii. Chalk second line parallel to first to accommodate staggered/cross bonded tile.
 - iii. Chalk additional lines, if necessary, to maintain alignment.
 - or,
2. Straight bond tile installation - (Not recommended for flat/low profile tile)
 - a. Gable end
 - i. Chalk vertical line one full tile width plus 1" to 2" from starting gable.
 - ii. Chalk additional lines, if necessary, to maintain alignment.

- b. Hip roof
 - i. Chalk vertical line 90 degrees from eave line.
 - ii. Chalk second line parallel to first to accommodate staggered/cross bonded tile.
 - iii. Chalk additional lines, if necessary, to maintain alignment.

C. Tile Installation

- 1. Stack tile to facilitate installation and minimize tile movement.
 - 2. Eave treatment - Choose one of the following:
 - a. Prefabricated Rubber Eave Closure - Install closure strip along eave. Fasten with minimum three fasteners per 36" strip (See Drawing 14).
or,
 - b. Metal Eave Closure - Install closure strip along eave. Fasten minimum 18" on center. If metal closure is inclusive of the drip edge fasten 6" on center (See Drawing 15).
or,
 - c. Raised Fascia/Wood Starter Strip - (when using a 3/4" fascia, a nominal 1" x 2" wood starter strip must be installed behind fascia).
 - i. Install fascia board approximately 3/4" above roof deck or a nominal 1" x 2" wood starter strip at roof edge (See Drawing 16).
Choose one of the following:
 - ii. Install 8" tapered cant strip at eave behind fascia and/or starter strip to support metal flashing when using drip edge.
or,
 - iii. Install a minimum 8" wide anti-ponding metal flashing to ensure positive drainage over fascia/starter strip. Tapered cant strip is optional when using anti-ponding metal. Nail top edge of flange onto roof.
- NOTE:** Limited to slopes 3:12 and over.
- iv. Apply underlayment as per Section 3.02.
or
 - d. Prefabricated concrete or clay eave closure (apply per manufacturer's instructions)

DRAWING 14

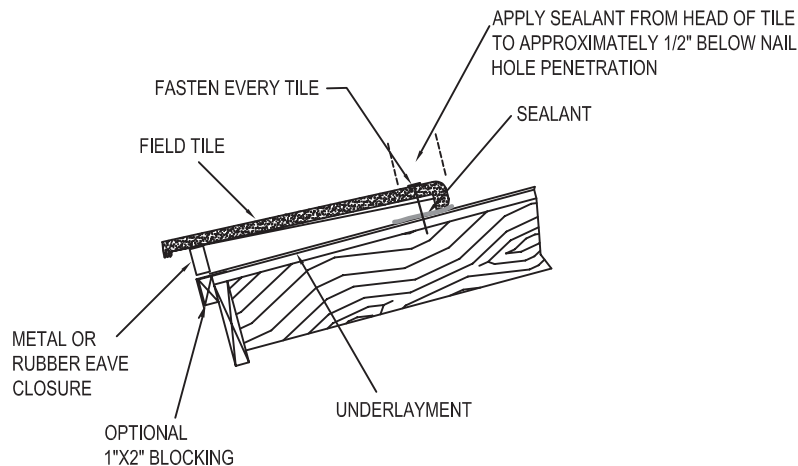

DRAWING 15

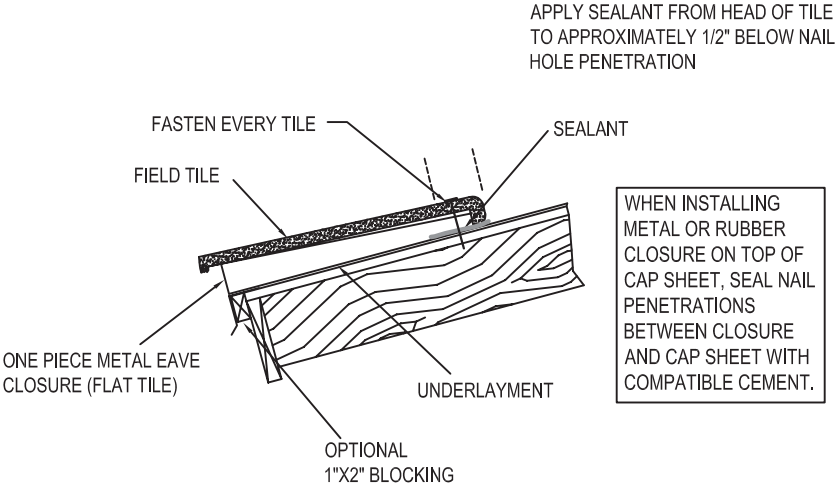

DRAWING 16

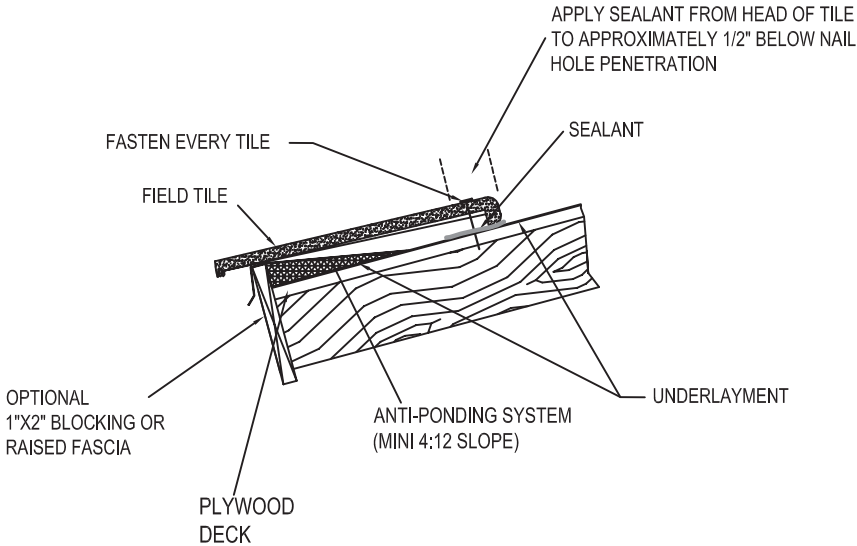

- e. Mortar Application - Install mortar to elevate eave edge.
 - i. Apply mortar along the eave edge, applying enough mortar to elevate the eave end of the tile to be on plane with the remaining roof tile.
 - ii. Point and smooth finish flush to eave line.
 - iii. A minimum 3/8" weephole flush with the roof underlayment shall be formed at the spacing of not less than one weephole per tile.

3.09 Flat/Low, Medium and High Profile Tile

- A. Starting at lower left corner (facing down roof) install first course of tile. Make certain all tile overhangs drip edge evenly along entire first course.
- B. Secure tile with fasteners through a minimum 1/8" thick compatible sealant applied to underlayment.

- C. Cut/break tile for proper staggering of tile courses when using staggered/cross bond method of installation.
- D. Set tile in stepped course fashion or in a horizontal and/or vertical fashion when utilizing straight bond method.
- E. Lay succeeding courses of field tile in same manner.
- F. Cut/break field tile to form straight edge at center of hip/ridge.

NOTE: Tile shall be attached to resist the aerodynamic moment determined when using the design pressures for the building and the fixing calculations set forth in the local building code.

3.10 Valleys - Choose one of the following:

NOTE: It is not recommended to install trim tile in the valleys. It may be necessary to remove the lugs from the field tile at walls and valley flashing for proper positioning of cut field tiles.

- A. Standard Roll Valley (See Drawing 17)
 - 1. Closed Valley - Miter tile to meet at center of valley.
 - 2. Open Valley - Chalk a line minimum 2” on both sides valley center. Place bed of mortar along outside edge of chalk lines. Miter tile to form straight border and point mortar to finish.
or,
- B. Preformed Metal Without Returns
 - 1. Closed Valley - Miter tile to form straight border on either side of water diverter. (See Drawing 18)
 - 2. Open Valley - Miter tile to form straight border on either side of the two water diverters. (See Drawing 19)

DRAWING 17

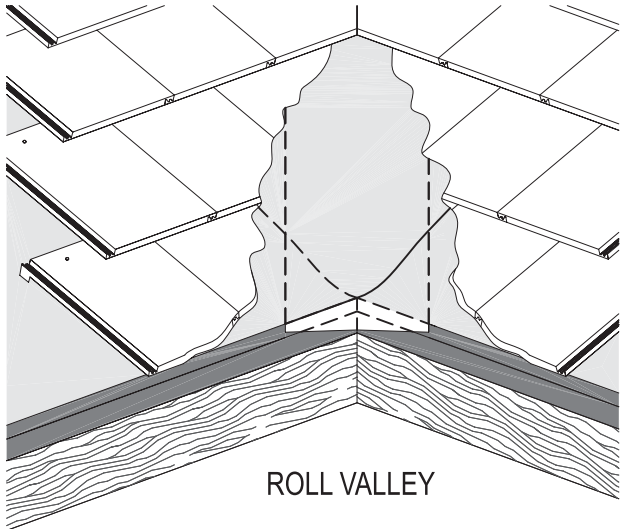

DRAWING 18

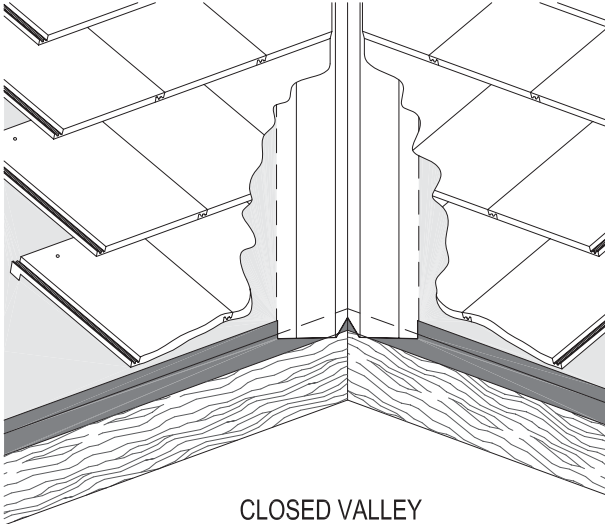

DRAWING 19

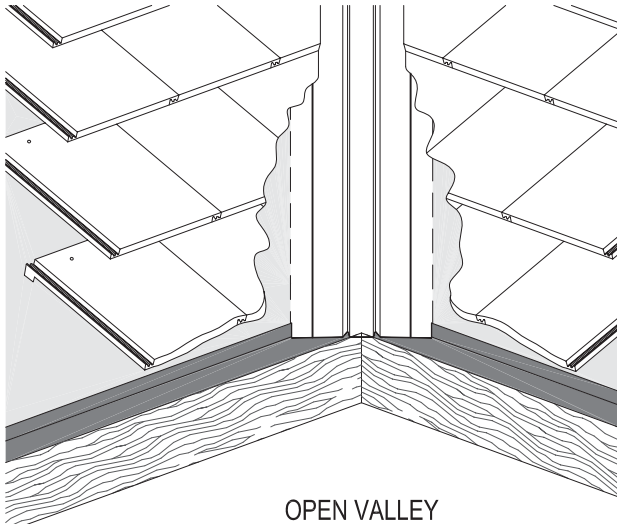

- 3.11 Hip Starter - Choose one of the following:
 - A. Prefabricated hip starter
 - 1. Miter tile as hip starter to match eave lines.
 - or,
 - B. Use standard hip tiles as starter.
- 3.12 Hip and Ridge Installation – (See Instructions for Hip and Ridge Attachment)
- 3.13 Hip and Ridge Nailer Boards - (See Instructions for Hip and Ridge Attachment)

- 3.14 Rake/Gable - Choose one of the following:
- A. Rake/Gable Tile
 1. Install first rake tile the exposed length of first course of field tile with factory finish of rake tile towards the eave.
 2. Fasten rake tile with a minimum two 10D nails and/or of sufficient length to penetrate the framing a minimum of 3/4".
 3. Abut each succeeding rake tile to the nose of the field tile above and maintain a constant head lap.
or,
 - B. Mortar Finish
 1. Place mortar bed along roof edge.
 2. Point smooth to a straight edge finish.
- 3.15 Wall Abutments
- A. Cut tile to fit approximately 1/2" to base of walls. Point-up mortar is optional.
- NOTE:** It may be necessary to remove lugs from the field tile and/or install batten extenders at wall flashing for proper positioning of cut field tiles. For tiles installed at headwalls, tile shall be installed with roof tile adhesive.
- 3.16 Plumbing Stacks
- A. Cut tile to fit close to plumbing stack, fill void with mortar and point to finish.
- 3.17 Coatings - (optional)
- A. Sealer may be applied to exposed mortar.
 - B. Color coordinated paint may be applied to all metal flashings.
- 3.18 Tile Replacement
- A. Damaged Tile
 1. Break out and replace damaged roof tile. Do not disturb underlayment. Repair underlayment if necessary.
 2. Apply adhesive per adhesive manufacturer's recommendations.
 3. Immediately set replacement tile in position assuring proper contact.
 - B. Small Valley and Hip Cut
 1. Elevate nose end of tile in course above small cut tile. Apply adhesive per adhesive manufacturer's recommendations.
 2. Immediately set tile in course above in position which assures proper contact.
- NOTE:** For roof slopes > 7":12" on hip cuts only, mechanical fastening may be required.
- 3.19 Clean-Up
- A. Remove all broken tile, debris and excess tile from roof.
- 3.20 Miscellaneous Recommendations
- A. Instructions shall be given to all parties involved cautioning against traffic of any kind on finished roof. Damage to roof tiles and/or sub-roof may result.

FRSA & TRI MODEL TILE GUIDELINES

System Three

Mortar Set Tile Applications Only

**Sealed underlayment system using standard metal flashings.
Tiles are applied with mortar direct to waterproofed deck.**

DISCLAIMER NOTICE (PLEASE READ CAREFULLY):

These mortar set fastened tile guidelines are a consensus document developed by a joint Task Force of the Florida Roofing, Sheet Metal and Air Conditioning Contractors Association (FRSA) and the Tile Roofing Institute (TRI). It is important to recognize that these recommendations are neither warranties, explicit or implicit, nor representative of the only method by which a mortar set tile system can be installed. Rather, they try to summarize for the designer, applicator or developer good roofing practice and some of the industry standards for the installation of mortar set tiles which have been developed over a period of time from actual trade practice and the requirements of various building code agencies. These guidelines may not be applicable in all geographical areas. **It is the responsibility of those individuals who are referring to these guidelines to independently research and determine which is best for their particular project.**

System Three

Mortar Set Tile Guidelines

NOTE: The following table provides the contractor with the choices available for underlayment systems. These systems can only be used on pitches designated in the table below:

Slope of Roof	Direct Deck Only	Choice of Underlayments	Plastic or Compatible Cement at Fasteners Penetrating Underlayments	Reference
2":12" and greater	Direct Deck	1. Hot Mop Application - No.30 or No.43 / 90# Organic or Modified Cap Sheet	Required	3.02A
2":12" and greater	Direct Deck	2. Cold Process Application - No.30 or No.43 / 90# Organic or Modified Cap Sheet	Required	3.02B
<p>NOTE: Alternate underlayments may be used based on laboratory or field testing.</p> <p>NOTE: Additional interplies may be used prior to installing cap sheet.</p>				

DIVISION 7

These guidelines cover Flat/Low, Medium and High Profile Roof Tile, using a minimum 2” tile headlap, or a design limited headlap, on minimum 15/32” solid decking nailed in compliance with wind load requirements.

- 07300 - Shingles and Roofing Tiles
- 07320 - Roofing Tiles
 - Mortar Set Tile Guidelines

PART I - GENERAL

- 1.01 Related Work Specified Elsewhere
 - A. Rough Carpentry - Section 06100.
 - B. Roof and Deck Insulation - Section 07220.
 - C. Flashing and Deck Insulation - Section 07600.
 - D. Roof Accessories - Section 07700.

- 1.02 Quality Assurance
 - A. Products.
 - 1. Concrete Roof Tile - In compliance with physical test requirements of the building code.
 - 2. Clay Roof Tile - In compliance with ASTM Standard C 1167.
 - B. Tile Attachment – Shall be in compliance with:
 - 1. ICC-SSTD-11
 - Or,
 - 2. TAS 101

- 1.03 Submittals
 - A. Samples - tile type and color as selected.
 - B. Manufacturer’s literature - including product descriptions and recommended installation procedures.
 - C. Tile Compliance Report.

- 1.04 Product Delivery, Storage and Handling
 - A. Distribute stacks of tile uniformly, not in concentrated loads.
 - B. When conditions warrant, install temporary battens to facilitate roof loading.
 - C. Care shall be taken to protect the underlayment during the tile loading and stacking process.

- 1.05 Job Conditions
 - A. Do not install underlayment on wet surfaces.
 - B. Ensure other trades are aware of precautions required when loading and stacking of tile, and their responsibility for protection of tile after loading and stacking is completed.
 - C. Any punctures or tears in the underlayment which occur during the loading and stacking of tile shall be immediately repaired with like materials.

- 1.06 Warranty
 - A. Materials - manufacturer’s limited warranty against defects in roof tile for ___ years.
(NOTE: Fill in appropriate number of years)

PART II - PRODUCTS

- 2.00 **DISCLAIMER NOTICE:** The FRSA and TRI rely on component industry data to establish minimum physical properties standards for their products. The standards listed in the Products section of this manual reflect that process.
- 2.01 Roof Tile
- A. Tile Manufacturer: _____
 - B. Tile Type: _____
 - C. Approximate Weight: _____
- 2.02 Asphalt Saturated Roofing Underlayments
- A. Organic, type II, commonly called No. 30 or 30#, conforming to ASTM Standard D 226, type II organic saturated.
 - B. Asphalt Saturated and Coated Organic Felt Base Sheet, commonly called No. 43 or 43#, per roll, conforming to ASTM D 2626.
 - C. Mineral surface roll roofing felt minimum 74 lbs. per roll commonly called 90# conforming to ASTM D 6380.
- 2.03 Membranes
- A. Organic - Asphalt impregnated cotton membrane, minimum 4" wide.
 - B. Inorganic - Asphalt impregnated fiberglass membrane, minimum 4" wide.
- 2.04 Fasteners
- A. Tile Fasteners
 - 1. Nails - corrosion resistant meeting ASTM A 641 Class 1 and/or corrosion resistance equal (according to ASTM B 117) of sufficient length to penetrate a minimum 3/4" into or through thickness of the deck.
 - a. Ring shank nails shall be 10d ring shank corrosion resistant steel nails (3 inches long, 0.283 inch flat head diameter, 0.121 inch shank diameter, 18-22 rings per inch)
 - b. Smooth or screw shank nails be 10d corrosion resistant steel (3 inches long, 0.28 inch flat head diameter, 0.128 inch screw or 0.131 inch smooth shank diameter).
 - 2. Screw Fasteners - corrosion resistant meeting ASTM A 641 Class 1 and/or corrosion resistance equal (according to ASTM B 117. Screws shall be 2 1/2" in length or penetrate a minimum 3/4" into the deck.
 - a. Minimum #8 course thread.
 - B. Underlayment Fasteners
 - 1. Nails or cap nails shall be of sufficient length to properly penetrate 3/4" into or through thickness of deck.
 - a. Minimum #1 gauge.
 - 2. Tin tags - not less than 1-5/8" nor greater than 2" in diameter and a minimum 32 gauge steel sheet metal.
 - 3. Cap Nails - 1" round 11 gauge of sufficient length to penetrate 3/4" into or through thickness of deck.
- 2.05 Metal Flashing
- A. Flashing shall be minimum 26 ga., G-90 corrosion resistant metal - conforming to ASTM A 525 and ASTM A 90, or other metal or composition profile materials as listed in the building code.
 - B. Lead for soil stacks shall be minimum 2.5 # per sq. ft. Lead weight flashing requirements follow the Lead Association recommendations.

- 2.06 Asphaltic Adhesive
- A. Asphalt plastic roof cement - conforming to ASTM D 4586, type II, non-asbestos, non-running, heavy body material composed of asphalt and other mineral ingredients.
 - B. Cold process modified bitumen roofing mastic - conforming to ASTM D 3019, type III.
 - C. Asphalt - conforming to ASTM D 312, type III or IV (Refer to slope requirements in the building code).
- 2.07 Adhesives / Sealants
- A. Structural bonding adhesive conforming to ASTM D 3498.
- 2.08 Mortar
- A. Materials
 - 1. Cement shall conform to ASTM C 91 Type M.
 - 2. Aggregates
 - a. Sand shall meet ASTM C 144, uniformly graded; clean and free from organic materials.
 - b. Lightweight aggregate shall meet ASTM C 332.
 - B. Mixes
 - 1. All mortar used to fasten field tiles shall be factory premixed and bagged and shall have a FBC (Florida Building Code) product approval.
 - 2. Job proportioned mixed (job site mortars) may be used for cosmetic purposes and for “wind block” only.
- 2.09 Eave Closure
- A. Prefabricated EPDM synthetic rubber conforming to ASTM D 1056.
 - B. Prefabricated metal eave closure.
 - C. Prefabricated concrete or clay eave closure.
 - D. Mortar (color optional) on granular surface underlayments only.
- 2.10 Coatings
- A. Paint - color coordinated paint for painting tile, flashing and/or accessories (optional).
 - B. Sealer - for point-up mortar (optional).
 - C. Tint Seal - color coordinated sealer for staining tile or accessories (optional).
- 2.11 Sheathing - Material shall conform to APA rated sheathing.
- NOTE:** Refer to building code Wind Load requirements.
- A. Minimum span rated 32/16; 15/32” thick APA rated sheathing.

PART III - EXECUTION

- 3.01 Inspection
- A. Verify that surfaces to receive underlayments are uniform, smooth, clean and dry.
 - B. Proper ventilation is recommended on all tile applications. Verify ventilation requirements as set forth in the building code.
- 3.02 Underlayment Application - Choose one of the following:
- NOTE 1:** On cap sheet, cut fishmouths and seal with flashing cement and membrane where applicable.
- NOTE 2:** Anchor sheet fastening shall be in accordance with Tables 1 to 5C

NOTE 3: Anchor sheet shall be in a minimum 2-ply in the valley.

A. Hot Mop Application - No.30 or No.43 / 90# Organic Cap Sheet (See Drawing 1)

A two ply roof application commonly called a ‘Hot Mop’ system. The roof cover is terminated at metal flashings. A No.30 or No.43 anchor sheet shall be mechanically attached to the wood deck with nails and tin caps, round cap nails or other fastener spaced according to tables 1 to 5C near the top edge of felt. Extend anchor sheet a minimum of 4” up vertical surfaces. Anchor sheet side laps shall be a minimum of 6” and head laps shall be a minimum of 2”. Over installed anchor sheet, apply a layer of organic cap sheet in an application rate of 25 #/sq. ± 15% mopping of asphalt. With this system the cap sheet may come in contact with the base sheet, allowing felt to touch felt. Side laps shall be a minimum of 6”; head laps shall be a minimum of 3” and back nailed 12” on center.

DRAWING 1

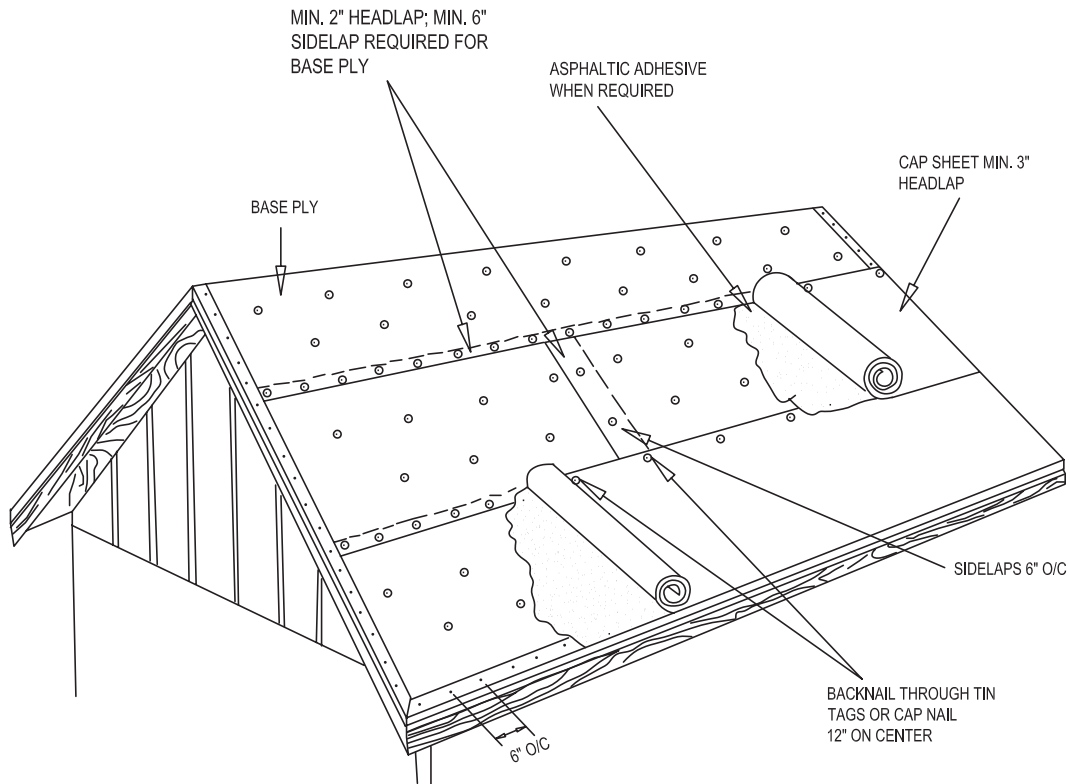

B. Cold Process Application - No.30 or No.43/90# Organic (See Drawing 1)

A two ply roof application commonly called a ‘Cold Process’ system. The roof cover is terminated at metal flashings. A No.30 or No.43 base ply sheet shall be mechanically attached to the wood deck with nails and tin caps, round cap nails or other fasteners spaced according to anchor sheet fastening tables 1 to 5C near the top edge of felt. Extend anchor sheet a minimum of 4” up vertical surfaces. Anchors sheet side laps shall be a minimum of 6” and head laps shall be a minimum of 2”. Over installed base sheet, apply a cap sheet according to underlayment/adhesive manufacturer recommendations. Cap sheet side laps shall be a minimum of 6”; head laps shall be a minimum of 3” and back nailed 12” on center.

NOTE: For Cold Process Systems, in windy conditions, it may be necessary to spot nail cap sheet laps at a of maximum 3’ on center.

- 3.03 Drip Edge Metal - choose one of the following: (For anti-ponding metal, see Section 3.08 C.2.c)
 - A. Edge metal shall be installed over the anchor sheet at all perimeters fastened 6” on center with 12 ga. corrosion resistant roof nails or other fasteners of compatible metals. All joints shall be lapped a minimum of 2”. Continue from eave up rake/gable in same manner, ensuring water shedding capabilities of all metal laps. The cap sheet shall be bonded to the metal with asphaltic adhesive.
 - or,
 - B. Drip edge metal shall be installed at the eave over the finished cap sheet. The metal shall be fastened 6” on center with 12 ga. corrosion resistant roofing nails, or other fasteners. All joints shall be lapped a minimum of 2”. The metal and underlayment sheet shall be joined with a bed of flashing cement and a 4” strip of asphalt saturated cotton or fiberglass fabric. The fabric shall be fully embedded in the flashing cement.

- 3.04 Valleys - Choose one of the following: (See Drawings 2, 3 & 4)
 - NOTE:** (See drawings 22, 23, 24) Outer edge of the valley metal shall overlap deck flange of drip edge a minimum of 1”. Center of valley flashing shall extend a minimum of 2” beyond drip edge.
 - NOTE:** Preformed valley metal shall be either a minimum width of 16” (24” stretch out) with a minimum 2 1/2” high center diverter or a ribbed design with 1” center diverter, a minimum four (4) 3/8” ribs spaced 3 1/2” with a 3 3/4” flange.
 - A. Standard roll metal, 16” wide, shall be placed over the anchor sheet in the valley and shall be fastened 6” on center with 12 ga. corrosion resistant roof nails, or other fasteners of compatible metals placed near the outside edge of the valley metal. All joints shall be lapped a minimum of 6” in a bed of flashing cement. The cap sheet shall be bonded to the metal with asphaltic adhesive.
 - or,

DRAWING 2

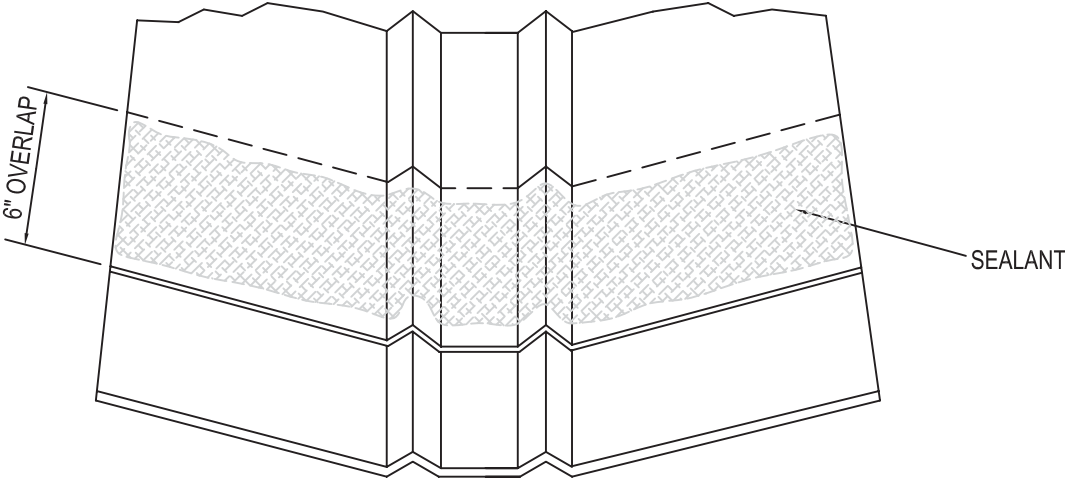

DRAWING 3

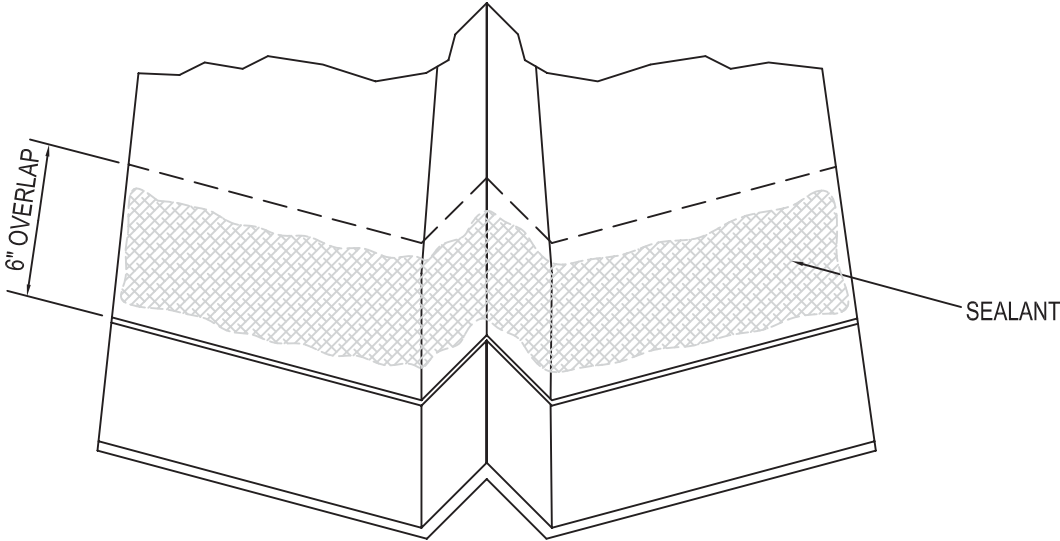

DRAWING 4

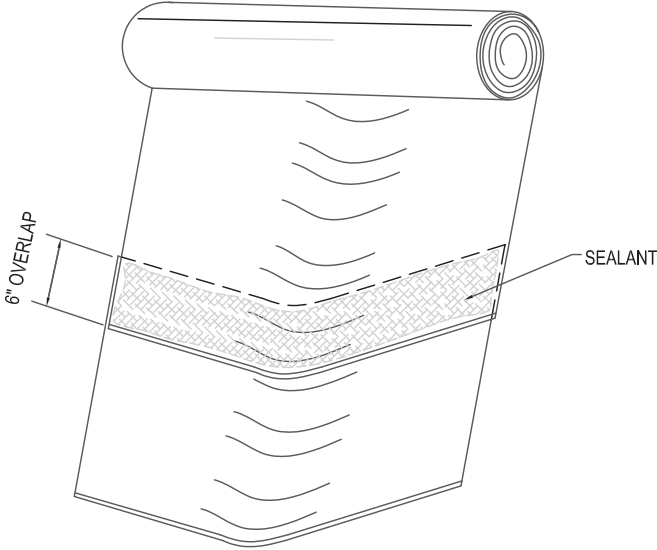

- B. Preformed metal without returns, 16” wide, shall be placed over the anchor sheet in the valley and shall be fastened 6” on center with 12 ga. corrosion resistant roof nails, or other fasteners of compatible metals placed near the outside edge of the valley metal. All joints shall be lapped a minimum of 6” in a bed of flashing cement. The cap sheet shall be bonded to the metal with asphaltic adhesive.
or,
- C. Preformed metal without returns 16” wide, shall be installed on top of cap sheet and placed in the valley and fastened 6” on center with 12 ga. corrosion resistant roof nails, or other fasteners of compatible metals. All joints shall be lapped a minimum of 6” and apply plastic cement between laps. The cap sheet shall be joined with a bed of flashing cement and a 4” strip of asphalt saturated cotton or fiberglass fabric. The fabric shall be fully embedded in the flashing cement. An optional sweat sheet may be applied prior to the installation of the valley metal and cap sheet.

- 3.05 Flashing and Counter Flashings at Wall Abutments - (Choose A or B)
- A. Install 4" x 5" "L" flashing flush to base of walls with 4" flange on the anchor sheet and nail near the outside edges of metal. Lap joints 4" and apply flashing cement between laps. Start at lower portion and work up to ensure water tightness. Nail 6" on center near the outside edge of the metal. The mineral surface cap sheet shall be bonded to the metal with asphaltic adhesive (See Drawings 5 & 6).
 - or,
 - B. Install a 4" x 5" "L" flashing on the top ply and fasten 6" on center with 12 ga. corrosion resistant roof nails, or other fasteners of compatible metals near the outside edge of the metal. All joints shall be lapped a minimum of 4" and apply plastic cement between laps. The cap sheet shall be joined to the "L" flashing with a bed of flashing cement and a 4" strip of asphalt saturated cotton or fiberglass fabric. The fabric shall be fully embedded in the flashing cement (See Drawings 7, 8, 9, 10).
 - C. Seal along top edge of vertical flange, covering all nail penetrations with flashing cement and membrane where required.
 - D. When installing optional counter flashing, lap top flange of base flashing a minimum of 3". Nail metal near the outside edge of metal a minimum of 6" on center or set into reglets (secured properly) and thoroughly caulk. Lap joints minimum 3" and apply flashing cement between laps.
- 3.06 Standard Curb Mounted Skylights, Chimneys, Etc. (See 3.05 above)
- A. Install in compliance with regular flashing installation procedures.
- NOTE:** For self curbing or prefabricated skylights, refer to skylight manufacturer's installation instructions.

DRAWING 5

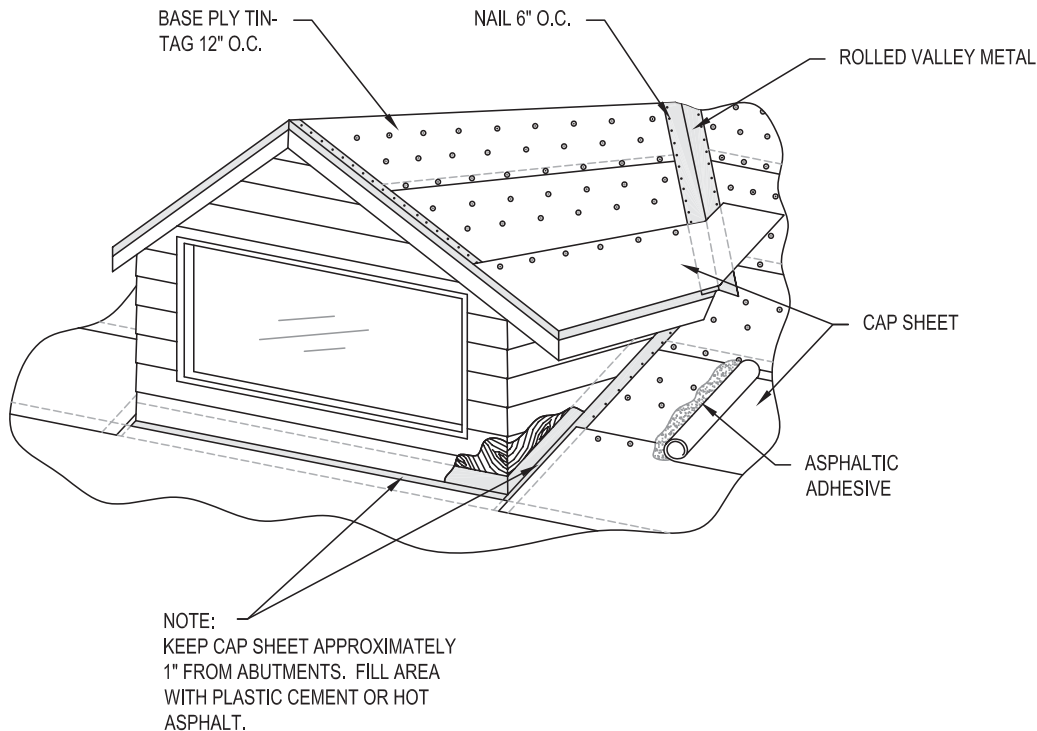

DRAWING 6

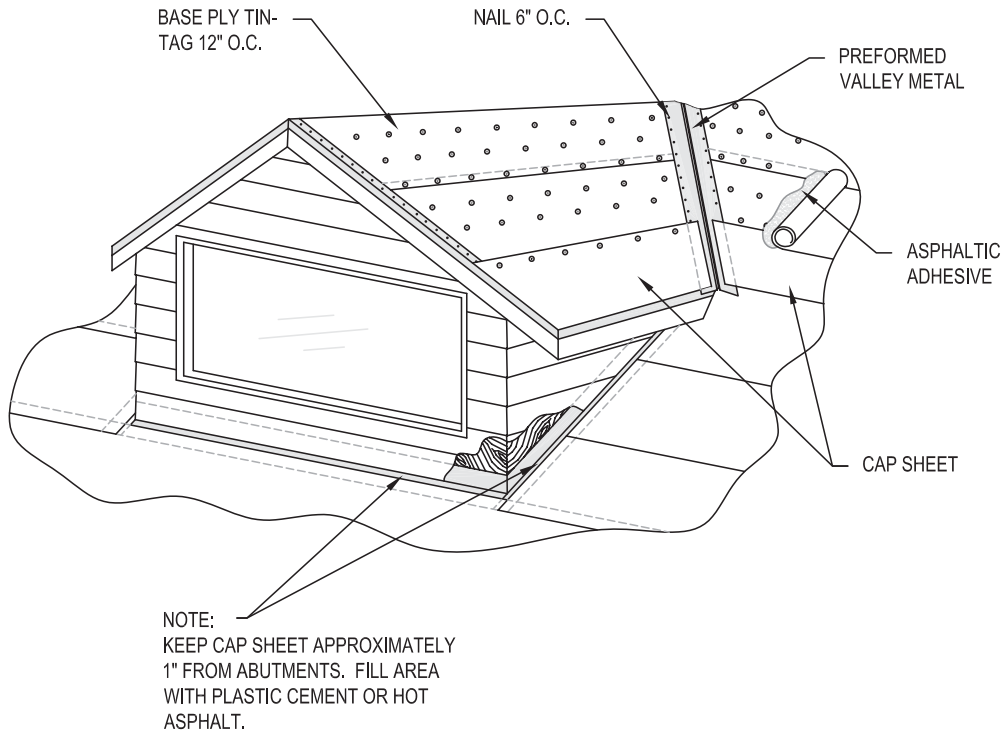

DRAWING 7

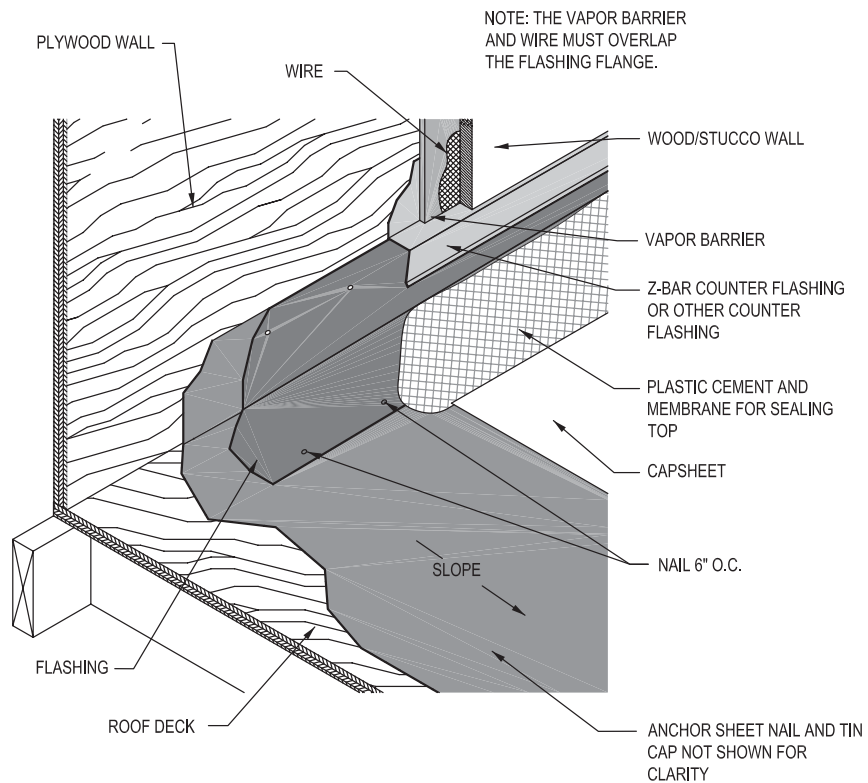

DRAWING 8

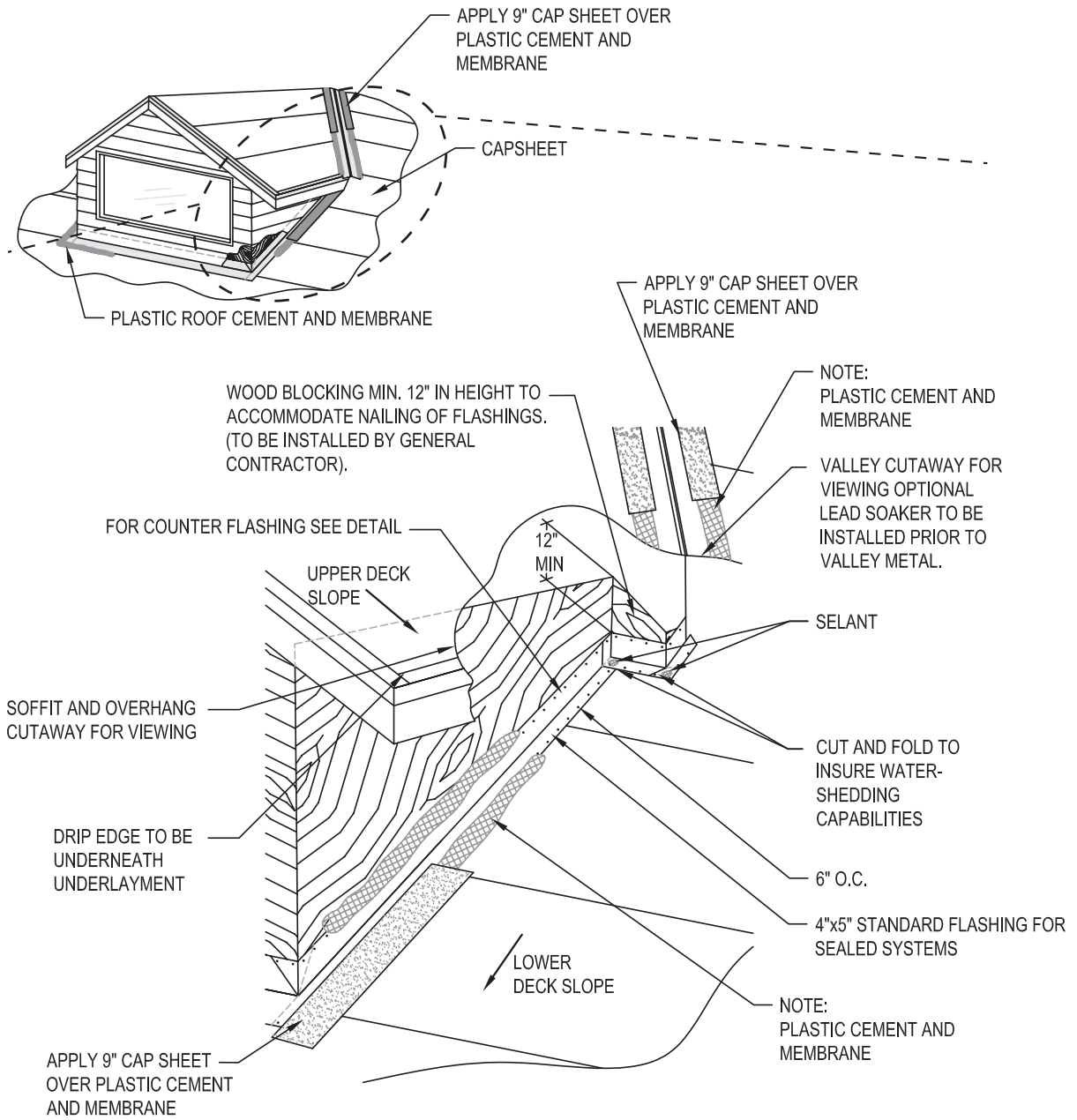

DRAWING 9

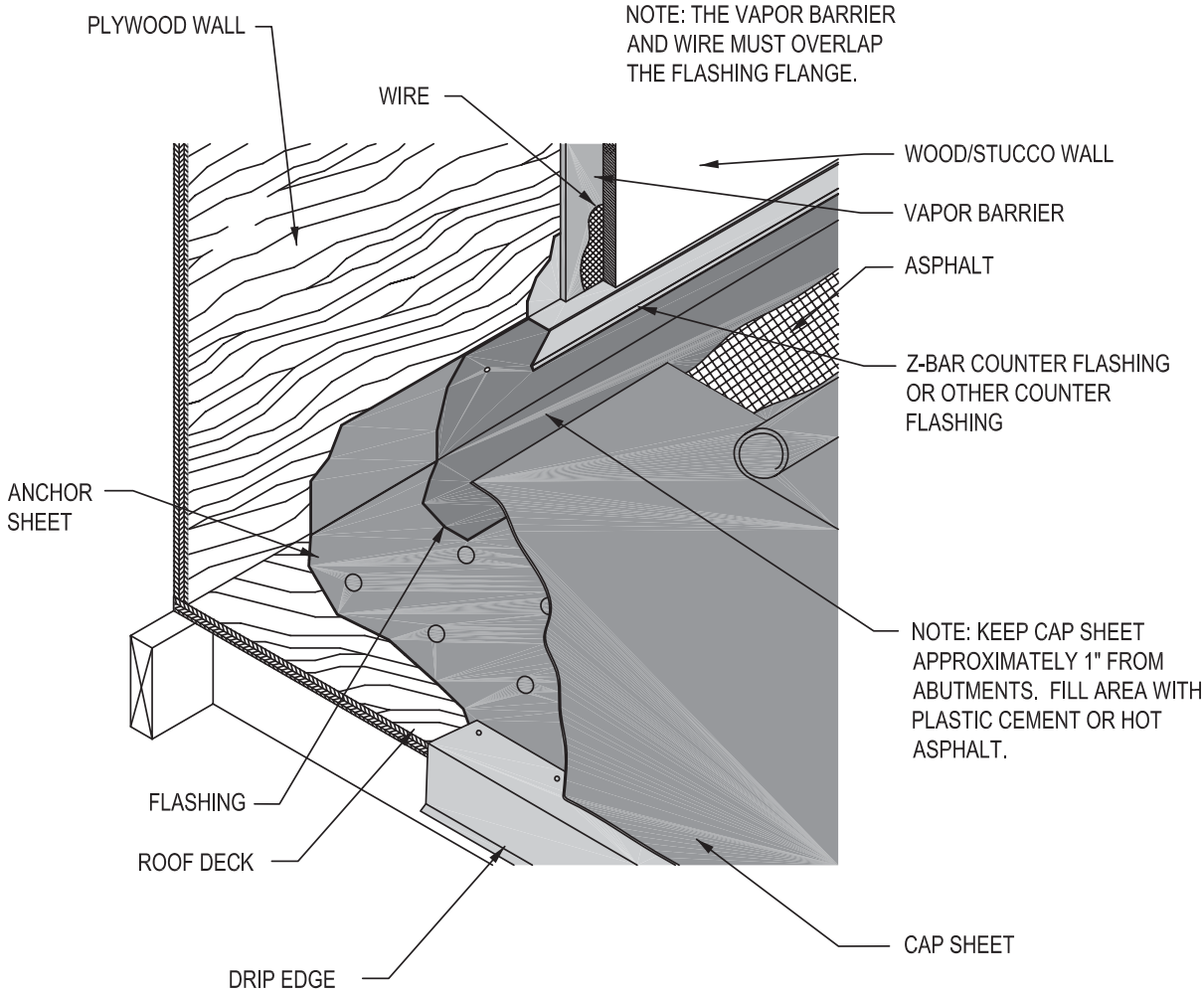

DRAWING 10

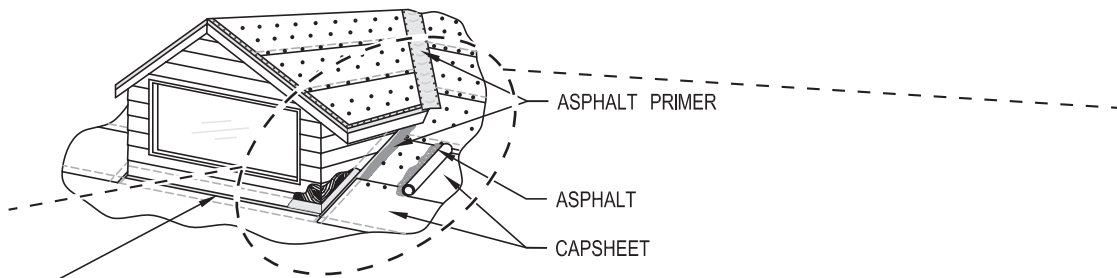

NOTE:
KEEP CAP SHEET APPROXIMATELY 1" FROM ABUTMENTS.
FILL AREA WITH PLASTIC CEMENT, HOT ASPHALT, OR PLASTIC CEMENT AND MEMBRANE.

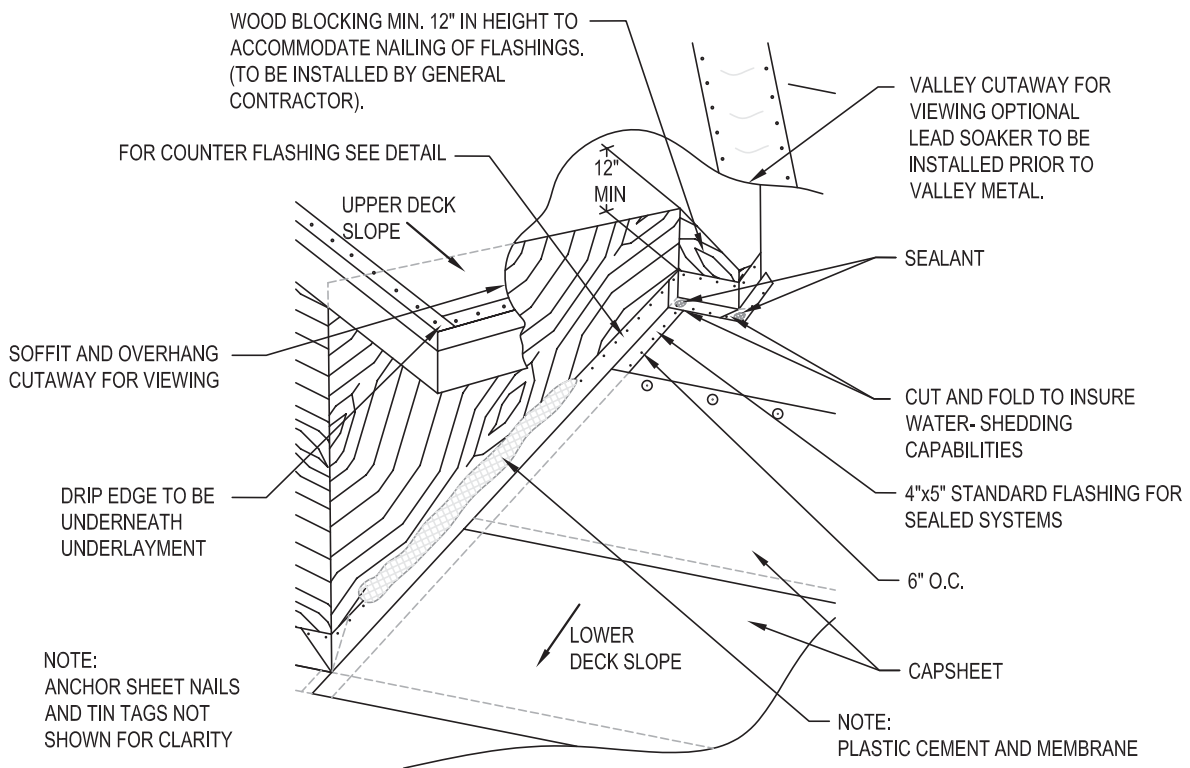

- 3.07 Pipes, Turbines, Vents, Etc. (See Drawings 11, 12, 13, 14)
- A. Apply flashing cement around base of protrusion and on the bottom side of metal flanges sealing unit base flashing to anchor sheet.
 - B. Nail and secure all sides of base flashing. Make certain base is flush to deck.
- NOTE 1:** If pipes, vents and/or turbines are installed after finished cap sheet has been applied follow instructions in 3.07 A & B, then the cap sheet and metal flange shall be joined with a bed of flashing cement and a strip of asphalt saturated cotton or fiberglass fabric. The fabric shall be fully embedded in the flashing cement.
- NOTE 2:** Profile specific ventilators should be installed as per manufacturer's installation instructions.

DRAWING 11

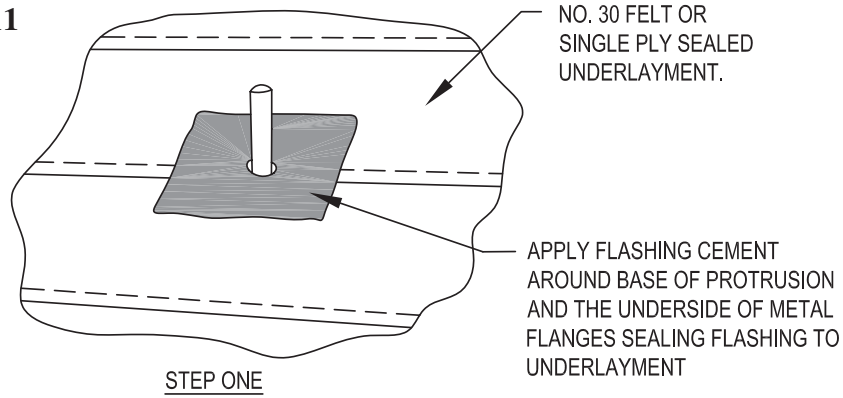

DRAWING 12

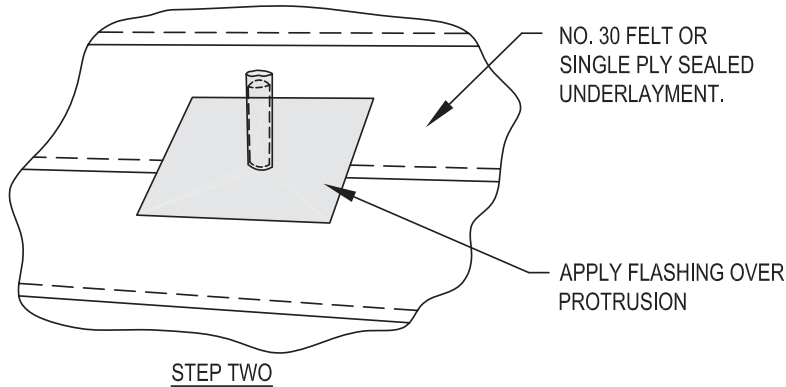

DRAWING 13

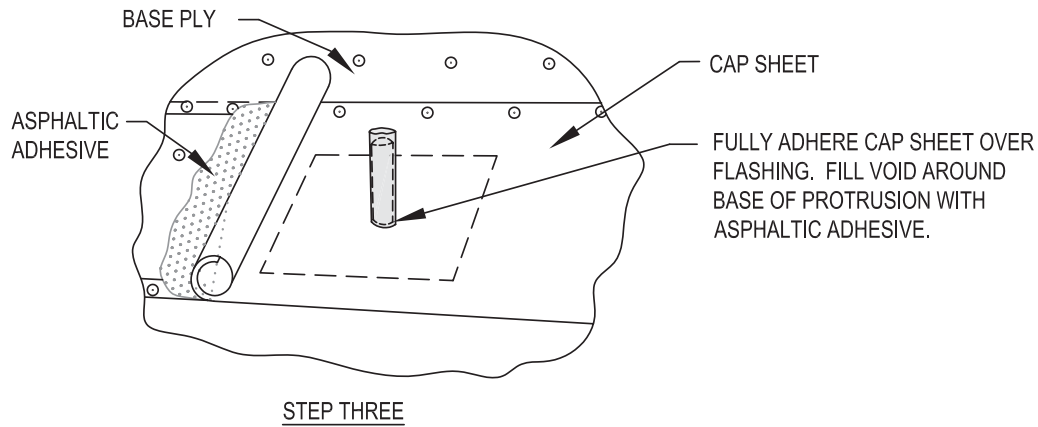

DRAWING 14

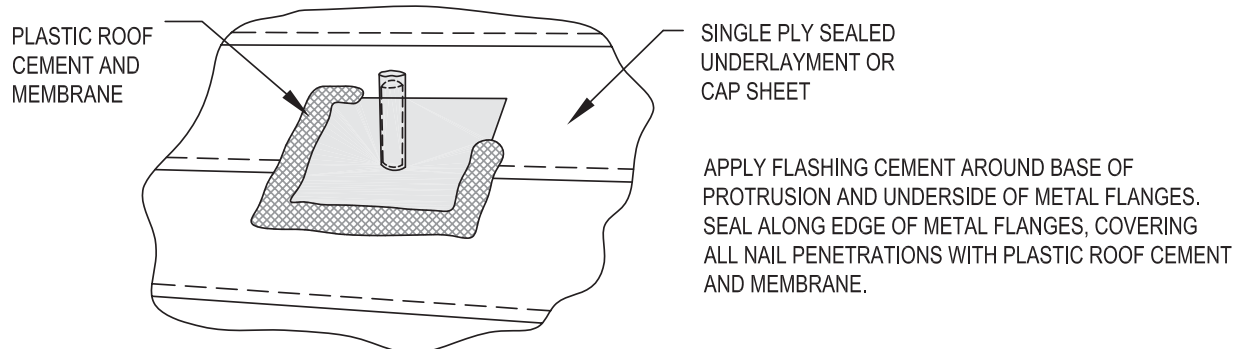

3.08 Tile Installation

A. Layout - Horizontal.

1. Chalk horizontal lines beginning one tile length from eave less desired overhang. Overhang shall be 3/4" to 2", depending on tile type, use of gutter, or other functional requirements.
2. Chalk succeeding lines to accommodate a minimum 2" headlap unless restricted by product design.
3. Increase headlap when necessary for equal course spacing.

B. Layout - Vertical - Choose one of the following:

1. Staggered/cross bond tile installation - (Recommended for Flat/Low profile tile)
 - a. Gable end - Choose one of the following.
 - i. Chalk vertical lines one full tile and one half tile width plus 1" to 2" from starting gable to accommodate rake tile.
or,
 - ii. Chalk vertical lines one full tile and one half tile width from starting gable to accommodate flush finish.
 - iii. Chalk additional lines, if necessary, to maintain alignment.

NOTE: Flush finish gable treatment can only be used when utilizing a single-ply peel and stick underlayment or a two-ply asphaltic adhesive underlayment system.

- a. Hip roof
 - i. Chalk vertical line 90 degrees from eave line.
 - ii. Chalk second line parallel to first to accommodate staggered/cross bonded tile.
 - iii. Chalk additional lines, if necessary, to maintain alignment.
or,
2. Straight bond tile installation - (Not recommended for Flat/Low profile tile))
 - a. Gable end - Choose one of the following.
 - i. Chalk vertical line one full tile width plus 1" to 2" from starting gable to accommodate rake tile.
or,
 - ii. Chalk vertical line one full tile width from starting gable to accommodate flush finish.
 - iii. Chalk additional lines, if necessary, to maintain alignment.
 - b. Hip roof
 - i. Chalk vertical line 90 degrees from eave line.
 - ii. Chalk second line parallel to first to accommodate staggered/cross bonded tile.
 - iii. Chalk additional lines, if necessary, to maintain alignment.

C. Tile Installation

1. Stack tile to facilitate installation and minimize tile movement.
2. Eave treatment - Choose one of the following. (See Drawing 15, 16 & 17).
 - a. Metal Eave Closure - install closure strip along eave. Fasten a minimum of 18" on center. If metal closure is inclusive of the drip edge fasten 6" on center.
or,
 - b. Prefabricated Rubber Eave Closure - install closure strip along eave. Fasten with a minimum 3 fasteners per 36" strip
or,
 - c. Raised Fascia/Wood Starter Strip

NOTE 1: The use of eave closure is required in a raised fascia system when using a medium or high profile tile.

- i. Install fascia board approximately 1 1/2” above roof deck or a nominal 2” x 2” starter strip at roof edge.
Choose one of the following:
 - ii. Install tapered cant strip at eave behind fascia and /or starter strip to support metal flashing and ensure positive drainage when using drip edge.
or,
 - iii. Install a minimum 8” wide anti-ponding metal flashing to ensure positive drainage over fascia/starter strip. Nail top edge of flange onto roof. Tapered cant strip is optional when using anti-ponding metal.
 - iv. Apply underlayment as per Section 3.02.
or,
- d. Prefabricated concrete or clay eave closure - (Applied per manufacturer’s specifications)
- e. Mortar Application - install mortar to elevate eave edge.
 - i. Apply mortar along the eave edge, applying enough mortar to elevate the eave end of the tile to be on plane with the remaining roof tiles.
 - ii. Point and smooth finish flush to eave line.
 - iii. A minimum 3/8” weephole flush with the roof underlayment at the spacing of not less than one weephole per tile.

DRAWING 15

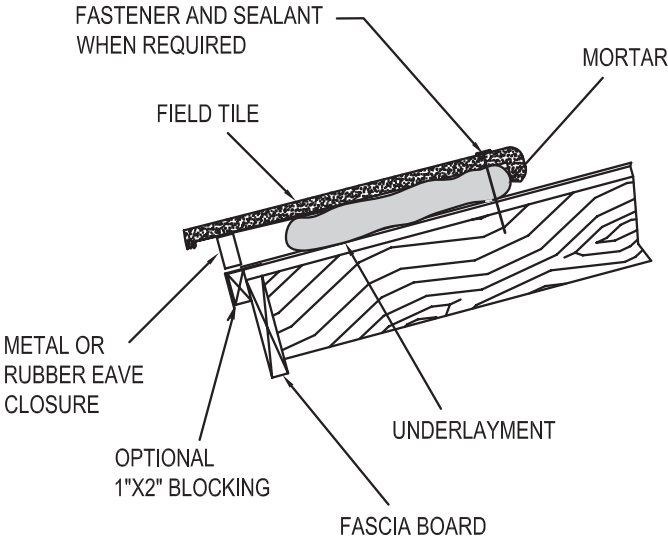

DRAWING 16

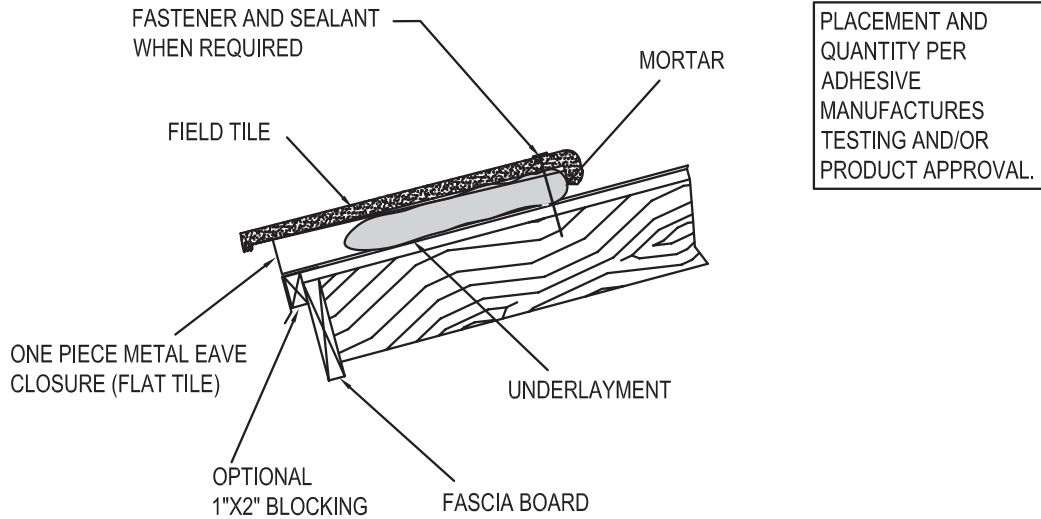

DRAWING 17

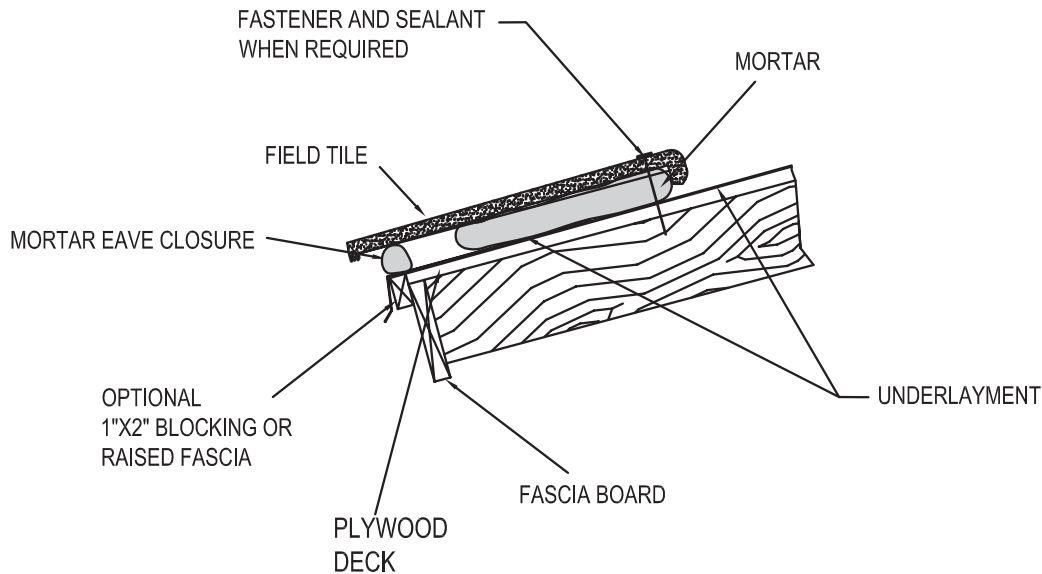

3.09 Flat/Low, Medium and High

NOTE: All mortar used to fasten field tiles shall be factory premixed and bagged and shall have a FBC(Florida Building Code) product approval.

NOTE: Mortar set tile shall be applied at an incline up to and including 6":12". For pitches above 6":12" up to and including 7":12" fasten every tile in the first course and every third tile in every fifth course in addition to mortar. For pitches above 7":12" fasten every tile in addition to mortar. (For two piece barrel tile see Section 3.09.C.) Apply flashing cement to seal all fastener penetrations.

NOTE: Tile shall be attached to resist the aerodynamic moment determined when using the design pressures for the building and fixing calculations set forth in the building code. Mortar quantities and placement determine the total resistance values. Consult with the

specific mortar manufacturer for amounts and specific resistance values. Values may be supplied through independent laboratory testing or field testing.

- A. Mortar Application: Flat/Low, Medium and High Profile Tile (See Drawings 18, 19, & 20)
- B. Install first course of tile, making certain all tile overhangs drip edge evenly along entire first course.
 - 1. Set tile in a bed of mortar. Apply 10” minimum length trowel of mortar vertically under pan. For Flat/Low tile place mortar vertically adjacent to the overlock of the tile being installed. Do not apply mortar under headlug of tile, or onto the underlock of adjacent tile which may create a tilted or cocked tile.
 - 2. Use half starter/finisher tile when provided or cut/break tile for proper staggering of tile courses when using the staggered/cross bond method of installation.
 - 3. Set tile in stepped course fashion or in a horizontal fashion when utilizing straight bond method.
 - 4. Lay succeeding course of field tile in same manner.
 - 5. Cut/break field tile to form straight edge at center of hip/ridge.

DRAWING 18

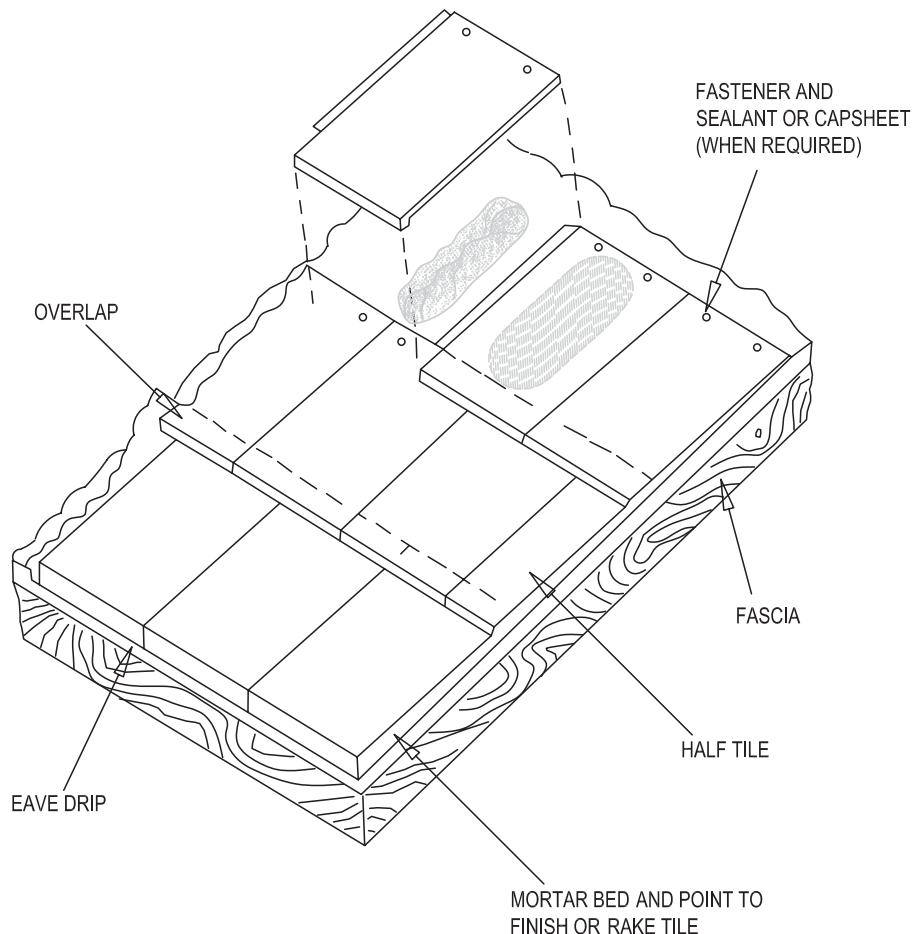

DRAWING 19

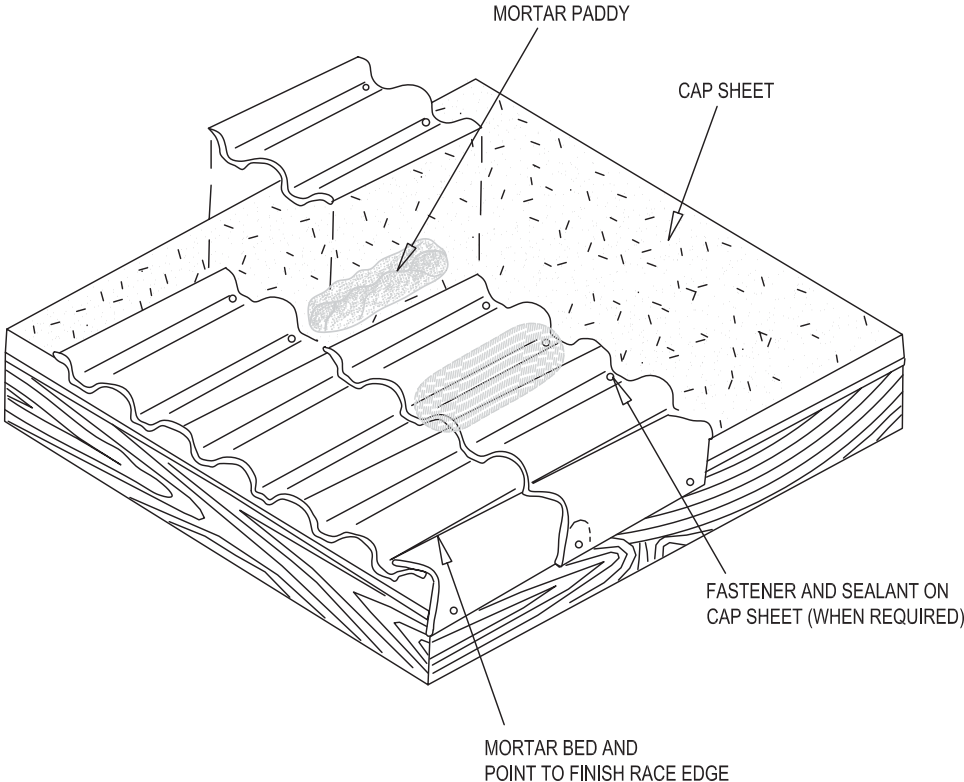

DRAWING 20

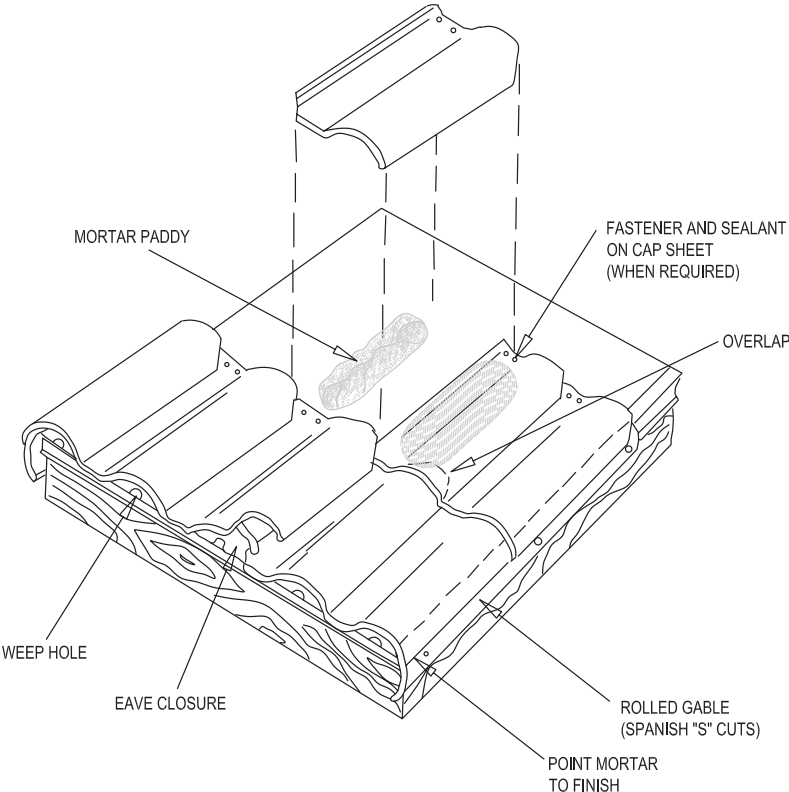

C. Mortar application. Two-Piece Barrel Tile (See Drawing 21)

NOTE: For pitches above 6:12 up to and including 7:12, fasten every pan tile in the first course and every fifth course thereafter in addition to mortar. For pitches above 7:12 fasten every pan tile in addition to mortar.

NOTE: Tile shall be attached to resist the aerodynamic moment determined when using the design pressures for the building and fixing calculations set forth in the building code. Mortar quantities and placement determine the total resistance values. Consult with the specific mortar manufacturer for amounts and specific resistance values. Values may be supplied through independent laboratory testing or field testing.

1. Apply 10” trowel of mortar vertically over chalk line and under center of each pan with narrow end facing down roof.
2. Place bed of mortar along inside edges of pans and set covers with wide end facing down roof.
3. Point mortar to form acceptable straight-edge finish ensuring contact along edges.
4. Lay succeeding courses of field tile in same manner.
5. Cut/break field tile to form straight edge at center of hip/ridge.

DRAWING 21

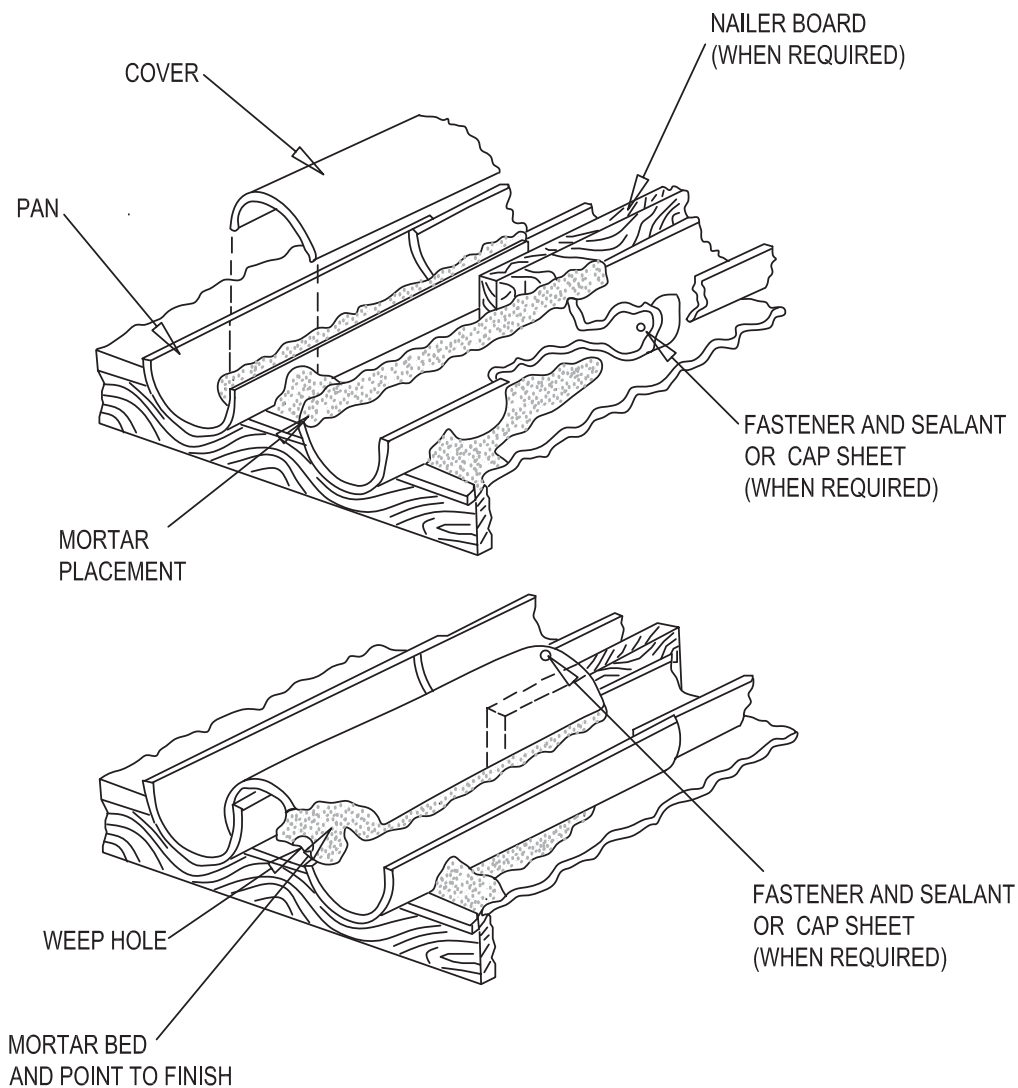

- 3.10 Valleys - Choose one of the following:
 - NOTE:** (See drawings 22 & 23) Outer edge of the valley metal shall overlap deck flange of drip edge a minimum of 1". Center of valley flashing shall extend a minimum of 2" beyond drip edge.
 - NOTE:** It may be necessary to remove the lugs from the field tile at walls and valley flashings for proper positioning of cut field tiles.
 - A. Standard Roll Valley (See Drawing 22)
 - 1. Closed Valley - Miter tile to meet at center of valley.
 - 2. Open Valley - Chalk a line minimum 2" on both sides valley center. Place bed of mortar along outside edge of chalk lines. Miter tile to form straight border and point to match tile surface.
 - 3. Valley with trim tile - Chalk a line down center of valley. Cut/break field tile near center line. Set trim tile in a continuous bed of mortar on tile surface, lapping tile a minimum of 1". Valleys shall remain unobstructed. Point mortar to finish. Ensure weep hole at end of valley.or,
 - B. Preformed Metal Without Returns
 - 1. Closed Valley - Miter tile to form straight border on either side of water diverter (See Drawing 23).
 - 2. Open Valley - Miter tile to form straight border on either side of two water diverters (See Drawing 24).

- 3.11 Hip Starter - choose one of the following:
 - A. Prefabricated hip starter
 - or,
 - B. Use standard hip tiles as starter.
 - 1. Miter tile to match eave lines.

- 3.12 Hip and Ridge Installation – Refer to instructions for hip and ridge attachment.

DRAWING 22

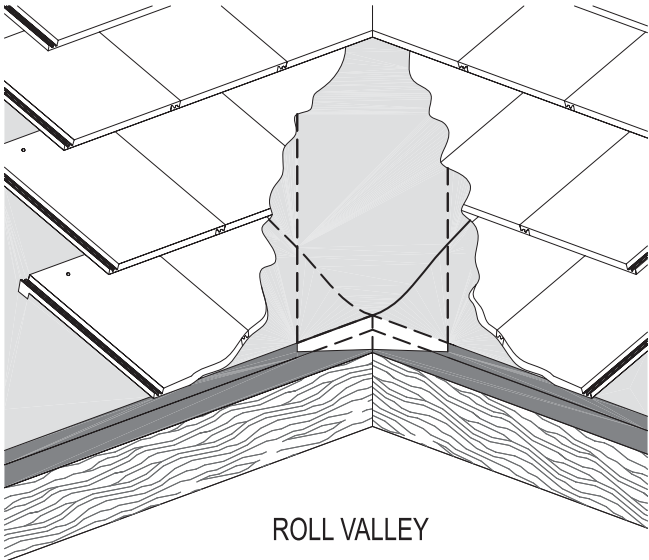

DRAWING 23

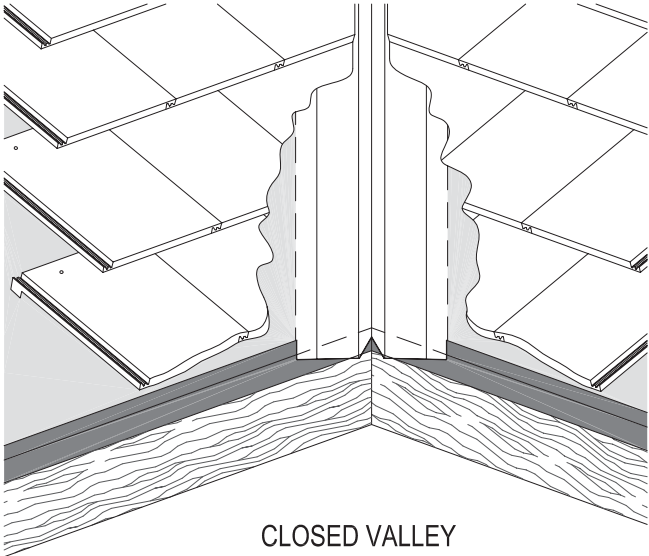

DRAWING 24

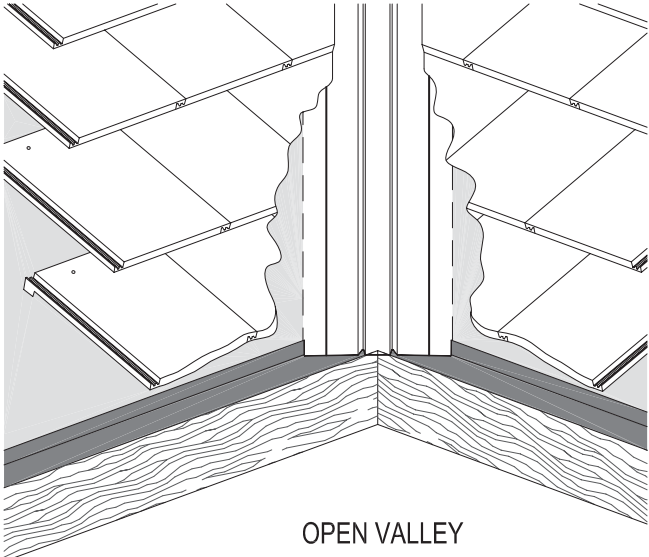

- 3.13 Hip and Ridge Nailer Boards – Refer to instructions for hip and ridge attachment.
- 3.14 Rake/Gable - Choose one of the following:
 - A. Rake/Gable Tile
 - 1. Install first rake tile to expose length of first course of field tile with factory finish of rake tile towards the eave.

2. Fasten rake tile with a minimum two 10D nails and/or of sufficient length to penetrate the framing a minimum of 3/4”.
 3. Abut each succeeding rake tile to the nose of the field tile above and maintain a constant headlap.
or,
B. Mortar Finish
- 3.15 Wall Abutments
- A. Cut tile to fit approximately 1/2” to base of walls. Point-up mortar is optional.
NOTE: It may be necessary to remove the lugs from the field tile at wall flashing for proper positioning of cut field tiles. For tiles installed at headwalls, tile shall be installed with roof tile adhesive.
- 3.16 Plumbing Stacks
- A. Cut tile to fit close to plumbing stack, fill void with mortar and point to finish.
- 3.17 Coatings - (Optional)
- A. Sealer may be applied to exposed mortar.
 - B. Color coordinated paint may be applied to all metal flashings.
 - C. Tint Seal - color coordinated sealer for staining tile, mortar or accessories.
- 3.18 Tile Replacement
- A. Damaged Tile
 1. Break out and replace damaged roof tile. Do not disturb underlayment. Repair underlayment if necessary.
 2. Apply roof tile adhesive per adhesive manufacturer’s recommendations.
 3. Immediately set replacement tile in position assuring proper contact.
 - B. Small Valley and Hip Cuts
 1. Elevate nose end of tile in course above small cut tile. Apply adhesive per adhesive manufacturer’s recommendations.
 2. Immediately set tile in course above in position which assures proper contact.
- 3.19 Clean-Up
- A. Remove all broken tile, debris and excess tile from roof.
- 3.20 Miscellaneous Recommendations
- Instructions shall be given to all parties involved cautioning against traffic of any kind on finished roof. Damage to roof tiles and/or sub-roof may result.

FRSA & TRI MODEL TILE GUIDELINES

System Four

Adhesive - Set Tile Guidelines

System “A”

Unsealed or sealed underlayment system using preformed metal flashings with edge returns. Tiles are applied over the underlayment with adhesive to the deck with or without horizontal battens.

Or,

System “B”

Sealed underlayment system using standard metal flashings. Tiles are applied with adhesive direct to waterproofed deck.

DISCLAIMER NOTICE (PLEASE READ CAREFULLY):

These adhesive-set tile guidelines are a consensus document developed by a joint task force of the Florida Roofing, Sheet Metal and Air Conditioning Association (FRSA) and the Florida Chapter of the Tile Roofing Institute (TRI). It is important to recognize that these recommendations are neither warranties, explicit or implicit, nor representative of the only method by which an adhesive set tile system can be installed. Rather, they try to summarize for the designer, applicator or developer good roofing practice and some of the industry standards for the installation of the adhesive set tiles which have been developed over a period of time from actual trade practice and the requirements of various building code agencies. These guidelines may not be applicable in all geographical areas. **It is the responsibility of those individuals who are referring to these guidelines to independently research and determine which is best for their particular project.**

Adhesive - Set Tile Guidelines

DIVISION 7

These recommendations cover Flat/Low, Medium, High and Two Piece Barrel Profile Roof Tile, using a 2” and 3” tile headlap or a design limited headlap, on minimum 15/32” solid decking nailed in compliance with wind load requirements.

- 07300 - Shingles and Roofing Tiles
- 07320 - Roofing Tiles
 - Mechanically Fastened Tile Recommendations
 - Adhesive - Set Tile Recommendations

PART I - GENERAL

- 1.01 Related Work Specified Elsewhere
 - A. Rough Carpentry - Section 06100
 - B. Roof and Deck Insulation - Section 07220.
 - C. Flashing and Deck Insulation - Section 07600.
 - D. Roof Accessories - Section 07700.
- 1.02 Quality Assurance
 - A. Products
 - 1. Concrete Roof Tile - In compliance with ASTM C 1492.
 - 2. Clay Roof Tile - In compliance with ASTM C 1167.
 - B. Tile Attachment – Shall be in compliance with:
 - 1. ICC-SSTD-11
 - Or,
 - 2. TAS 101
- 1.03 Submittals
 - A. Samples - tile type and color as selected.
 - B. Manufacturer’s literature - including product descriptions and recommended installation procedures.
 - C. Tile Compliance Report.
- 1.04 Product Delivery, Storage and Handling
 - A. Distribute stacks of tile uniformly, not in concentrated loads.
 - B. When stacking tile on roof top prior to installation, install battens under nose of tile stacks when required.
 - C. Care shall be taken to protect the underlayment during the tile loading and stacking process.
- 1.05 Job Conditions
 - A. Do not install underlayment or tiles on wet surfaces.
 - B. Ensure other trades are aware of precautions required when loading and stacking of tile, and their responsibility for protection of tile during and upon loading and stacking completion.
 - C. Any punctures or tears in the underlayment which occur during the loading and stacking of tile shall be immediately repaired with like materials.
- 1.06 Warranty
 - A. Materials - refer to specific manufacturer’s limited warranty.

PART II - PRODUCTS

- 2.00 **DISCLAIMER NOTICE:** The FRSA and TRI rely on component industry data to establish minimum physical properties standards for their products. The standards listed in the Products section of this manual reflect that process.
- 2.01 Roof tile
- A. Tile Manufacturer: _____
 - B. Tile Type: _____
 - C. Approximate Weight: _____
- 2.02 Asphalt Saturated Roofing Underlayments
- A. Organic, type II, Commonly called No. 30 or 30#, conforming to ASTM Standard D 226, type II organic saturated.
 - B. Asphalt -Saturated and Coated Base Sheet, commonly called No. 43 or 43 #, per roll, conforming to ASTM D 2626.
 - C. Mineral surface roll roofing - Type 1, minimum 74 # per 100 sq. ft., commonly called 90 #, conforming to ASTM D 6380.
 - D. Modified bitumen single ply membrane, minimum 40 mils.
 - E. Self -adhered membrane, minimum 40 mils.
 - F. Granular surface SBS modified bitumen membrane, minimum 40 mils at the selvage edge.
- 2.03 Membranes
- A. Organic - Asphalt impregnated cotton membrane, minimum 4” wide.
 - B. Inorganic - Asphalt impregnated fiberglass membrane, minimum 4” wide.
- 2.04 Fasteners
- A. Tile Fasteners
 - 1. Nails - corrosion resistant meeting ASTM A 641 Class 1 and/or corrosion resistance equal (according to ASTM B 117) of sufficient length to penetrate a minimum 3/4” into or through thickness of the deck or batten, whichever is less.
 - a. Ring shank nails shall be 10d ring shank corrosion resistant steel nails (3 inches long, 0.283 inch flat head diameter, 0.121 inch shank diameter, 18-22 rings per inch).
 - b. Smooth or screw shank nails be 10d corrosion resistant steel (3 inches long, 0.28 inch flat head diameter, 0.128 inch screw or 0.131 inch smooth shank diameter).
 - 2. Screw Fasteners - corrosion resistant meeting ASTM A 641 Class 1 and/or corrosion resistance equal (according to ASTM B 117). Screws shall be 2 1/2” in length penetrate a minimum 3/4” into the deck or batten, whichever is less.
 - B. Underlayment Fasteners
 - 1. Nails or cap nails shall be of sufficient length to properly penetrate 3/4” into or through thickness of deck.
 - a. Minimum #1 gauge.
 - 2. Tin tags - not less than 1-5/8” nor greater than 2” in diameter and a minimum 32 gauge steel sheet metal.
- 2.05 Metal Flashing
- A. Flashing shall be minimum 26 ga., G-90 corrosion resistant metal - conforming to ASTM A 525 and ASTM A 90, or other metal or composition profile materials as listed in the building code.
 - B. Lead for soil stacks shall be minimum 2.5 # per sq. ft. Lead weight flashing requirements follow Lead Association recommendation.

- 2.06 Asphaltic Adhesive
 - A. Asphalt plastic roof cement - conforming to ASTM D 4586, type II, non-asbestos, non-running, heavy body material composed of asphalt and other mineral ingredients.
 - B. Cold process modified bitumen roofing mastic - conforming to ASTM D 3019, type II.
 - C. Asphalt - conforming to ASTM D 312, type III and IV (Note slope requirements in the building code).

- 2.07 Roof Tile Adhesive - Conforming to section 2.09 below.
 - A. One Component
 - B. Two Component

- 2.08 Mortar (When Used For Trim Tiles Or As Eave Closure Only)
 - A. Materials
 - 1. Cements shall conform to ASTM C 91 Type M.
 - 2. Aggregates
 - a. Sand shall meet ASTM C 144, uniformly graded, clean and free from organic materials.
 - b. Lightweight aggregate shall meet ASTM C 332.
 - B. Mixes
 - 1. All mortar used to fasten hips and ridges shall, in addition to having a FBC product approval, be tested in accordance with ICC-SSTD-11 with data substantiating compliance.
 - 2. Job proportioned mixes (job site mortars) may be used for cosmetic purposes and for “wind block” only.

- 2.09 Polyurethane adhesives
 - A. Polyurethane adhesive conforming to the following specifications.
 - 1. Density conforming to ASTM D 1622.
 - 2. Compressive strength conforming to ASTM D 1621.
 - 3. Tensile strength conforming to ASTM D 1623.
 - 4. Water absorption conforming to ASTM D 2842.
 - 5. Moisture vapor transmission conforming to ASTM E 96.
 - 6. Dimensional stability conforming to ASTM D 2126.
 - 7. Closed cell content conforming to ASTM D 2856.
 - 8. Surface burning characteristics conforming to ASTM E 84.
 - 9. Fire tests of roof coverings conforming to ASTM E 108.

- 2.10 Eave Closure
 - A. Prefabricated EPDM synthetic rubber conforming to ASTM D 1056.
 - B. Prefabricated metal eave closure.
 - C. Prefabricated concrete or clay eave closure.
 - D. Mortar (color optional) on granular surface underlayments only.

- 2.11 Coating
 - A. Paint - color coordinated paint for painting tile, flashing and/or accessories (optional).
 - B. Sealer - for point-up mortar (optional).
 - C. Tint Seal - color coordinated sealer for staining tile or accessories (optional).

2.12 Sheathing - Material shall conform to APA rated sheathing.

NOTE: Refer to building code wind load requirements.

A. Minimum span rated 32/16; 15/32" thick APA rated sheathing.

B. Battens - material to be decay resistant.

1. Battens shall not be bowed or twisted.

2. Horizontal battens should be a nominal 1" x 2".

C. Nailer Boards - material to be decay resistant.

1. Nailer boards shall not be bowed or twisted.

2. Nailer boards shall be a nominal 2 inches x (sufficient height to satisfy conditions).

System Four

Adhesive-Set Tile Guidelines Underlayment Option “A”

NOTE: The following table provides the contractor with the choices available for underlayment systems. These systems can only be used on pitches designated in the table below:

Slope of Roof	Battens or Direct Deck	Choice of Underlayments	Plastic or Compatible Cement at Penetrating Underlayments	Reference
4" : 12" and greater	Either	1. Single-ply 90# Organic Cap Sheet or Modified Cap Sheet	Not Required	3.02A
4" : 12" and greater	Either	2. Hot Mop Application - No.30 or No.43 / 90# Organic or Modified Cap Sheet	Not Required	3.02B
4" : 12" and greater	Either	3. Cold Process Application - No.30 or No.43 / 90# Organic or or Modified Cap Sheet	Not Required	3.02C
4" : 12" and greater	Either	4. Self-Adhered Underlayment -Applied Direct to Wood Deck	Not Required	3.02D
4" : 12" and greater	Either	5. No.30/Self-Adhered Underlayment	Not Required	3.02E
As tested	Either	6. Alternative Membranes	Not Required	3.02F
<p>NOTE: All applications above must use preformed flashings with metal edge returns and a 3" tile headlap unless restricted or dictated by product design.</p> <p>NOTE: Not all tiles are designed to be engaged over battens. Check with roof tile manufacturer.</p>				

System #4 - Option “A”

3.02 Underlayment Application - Choose one of the following:

NOTE: On cap sheet, cut fishmouths and seal with compatible flashing cement and membrane where applicable.

NOTE: Anchor sheet fastening shall be in accordance with Tables 1 to 5C.

NOTE: Anchor sheet shall be a minimum 2-plys in the valley.

NOTE: A No.15, No.30 or No.43 can be used as a dry in prior to installing the underlayment with this system (except on 3.02 D).

A. Single-ply 90# Organic Cap Sheet or Modified Cap Sheet (See Drawing A-1)

A 90# organic cap sheet or modified cap sheet underlayment application can be installed with tiles applied direct to the cap sheet. Prior to applying the 90# or modified cap sheet, attach a 36” wide strip of same underlayment, (sweat sheet) down the center of the valley. Secure near the edge of the felt 24” on center. Apply a 90# or modified cap sheet perpendicular to the slope of the roof and mechanically attached to the wood deck with nails and tin caps, round cap nails or other fasteners according to the Anchor Sheet Fastening Tables 1 to 5C near the top edge of felt. Use a minimum 4” head lap and 6” side laps. Extend anchor sheet up vertical surfaces a minimum 4”. Overlap hip and ridges a minimum of 6”. Secure near the edge of felt 12” on center at overlaps and side laps of the underlayment.

DRAWING A-1

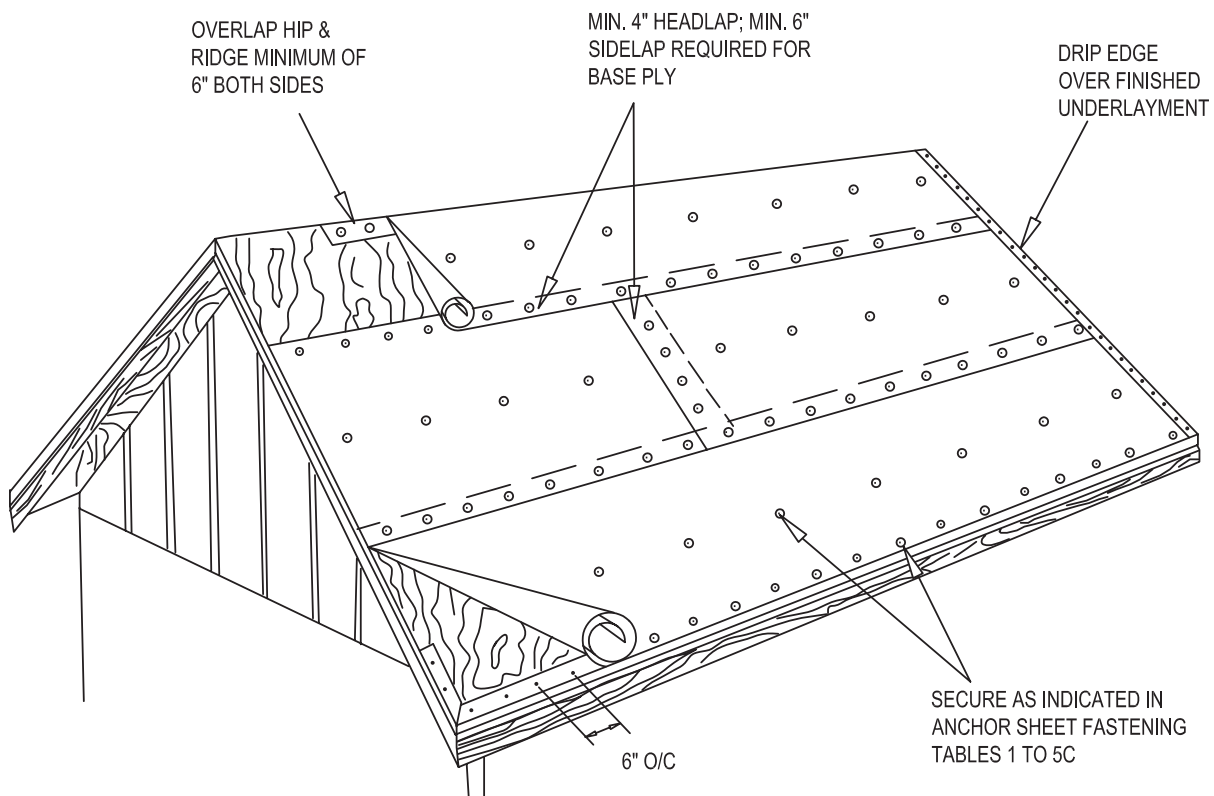

- B. Hot Mop Application - No.30 or No.43 / 90# Organic or Modified Cap Sheet (See Drawing A-2)
 A two ply roof application commonly called a ‘Hot Mop’ system. The roof cover is terminated at metal flashings. A No.30 or No.43 anchor sheet shall be mechanically attached to the wood deck with nails and tin caps, round cap nails or other fasteners spaced according to Anchor Sheet Fastening Tables 1 to 5C near the top edge of felt. Extend anchor sheet a minimum of 4” up vertical surfaces. Anchor sheet side laps shall be a minimum of 6” and head laps shall be a minimum of 2”. Over installed anchor sheet, apply a layer of organic cap sheet with an application rate of 25 #/sq. ± 15% mopping of asphalt. With this system the cap sheet may come in contact with the base sheet, allowing felt to touch felt. Side laps shall be a minimum of 6”; head laps shall be a minimum of 3” and back nailed 12” on center.
- C. Cold Process Application - No.30 or No.43/90# Organic or Modified Cap Sheet (See Drawing A-2)
 A two ply roof application commonly called a ‘Cold Process’ system. A No.30 or No.43 anchor sheet shall be mechanically attached to the wood deck with nails and tin caps, round cap nails or other fasteners spaced according to Anchor Sheet Fastening Tables 1 to 5C. Extend anchor sheet a minimum of 4” up vertical surfaces. Anchor sheet side laps shall be a minimum of 6” and head laps shall be a minimum of 2”. Over installed anchor sheet, apply a cap sheet in a continuous layer of cold process adhesive at the rate of 1.5 gal/sq. or according to underlayment/adhesive manufacturers’ recommendation. Cap sheet side laps shall be a minimum of 6”; head laps shall be a minimum of 3” and back nailed 12” on center.
- NOTE:** For Cold Process Systems, in windy conditions, it may be necessary to spot nail cap sheet at a maximum of 3 feet on center.

DRAWING A-2

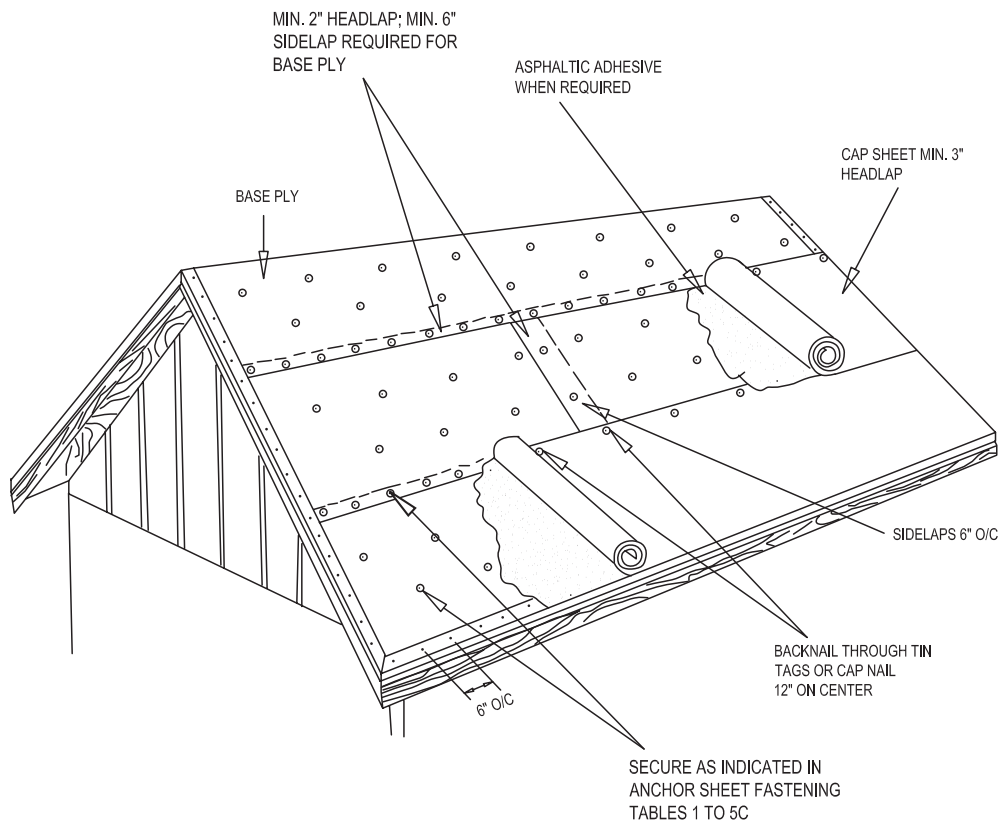

- D. Self-Adhered Underlayment - Applied Direct to Wood Deck.
A single ply underlayment system utilizing self-adhered underlayment. Apply one layer of self-adhered underlayment in compliance with the self-adhered underlayment manufacturers' recommendations.
 - E. No.30/Self-Adhered Underlayment
A two ply roof application utilizing a self-adhered underlayment. No.30 felt shall be mechanically attached to the wood deck with nails and tin caps, round cap nails or other fasteners spaced according to Anchor Sheet Fastening Tables 1 to 5C. Extend anchor sheet a minimum of 4" up vertical surfaces. Anchor sheet side laps shall be a minimum of 6" and head laps shall be a minimum of 2". Over installed anchor sheet, apply one layer of self-adhered underlayment in compliance with the self-adhered underlayment manufacturers' recommendation.
 - F. Alternative Membranes
Any product consisting of one or more water shedding layers applied to a sloped roof prior to the application of a prepared roof covering having been tested in compliance with the building code. The primary purpose of an underlayment is defined as a water shedding layer to function in combination with a prepared roof covering.
- 3.03 Drip Edge Metal - Choose one of the following: (For anti-ponding metal, see Section 4.02 B.3).
- A. Single ply underlayment systems
 1. Drip edge metal shall be installed at the eave, over the sheathing. The metal shall be fastened 6" on center with 12 ga. corrosion resistant roofing nails or fasteners of compatible metals. All joints shall be lapped a minimum of 2". The metal shall be coated with a bed of flashing cement.
 2. Apply underlayments as per section 3.02 A or B for single ply underlayments.
or,
 - B. 2-ply underlayment systems
 1. Drip edge metal shall be installed over anchor sheet, fastened 6" on center with 12 ga. corrosion resistant roof nails or fasteners of compatible metals. All joints shall be lapped a minimum of 2".
 2. Continue from eave up rake/gable in same manner, ensuring water shedding capabilities of all metal laps.
 3. The cap sheet shall be bonded to the metal with asphaltic adhesive.
- 3.04 Gable treatment -Choose one of the following:
- NOTE:** For two-ply underlayment systems see section 3.03 B.
- A. Underlayment wrapped gable - Choose one of the following:
NOTE: Not Recommended for flush finish. Rake tiles must be installed.
 1. Extend underlayment beyond rake/gable end. Fold down onto fascia or barge board. Secure with nails and tin tags, round cap nails or other fasteners 6" on center.
or,
 2. Trim underlayment at fascia or barge board. Install a peel and stick underlayment extending underlayment beyond rake/gable end. Fold down and seal onto fascia or barge board.
or,
 - B. Metal Finish
 1. Drip edge metal shall be installed at the gable, over the finished underlayment. The metal shall be fastened 6" on center with 12 ga. corrosion resistant roofing nails or fasteners of compatible metals. Continue from eave up rake/gable in same manner, insuring water shedding capabilities of all metal laps.

3.05 Valleys - Choose one of the following:

NOTE: (See drawing 4.05, 4.06, 4.07) Outer edge of the valley metal shall overlap deck flange of drip edge a minimum of 1". Center of valley flashing shall extend a minimum of 2" beyond drip edge.

NOTE: Where special conditions exist, it may be necessary to increase the width of the valley metal.

NOTE: Install preformed closed valley minimum width of 16" (24" stretch out) with a minimum 2 1/2" high center diverter and 1" edge returns or a ribbed design with 1" center diverter, a minimum of four (4) 3/8" ribs spaced 3 1/2" with 3 3/4" flange.

A. Install preformed closed valley. Lap all joints a minimum of 6" and apply a coating or separator sheet for corrosion resistance (See Drawing A-3)

or,

B. Install preformed open valley with a minimum width of 16" (24" stretch-out) with a minimum 1" high twin center diverter and minimum 1" metal edge returns. Lap joints a minimum 6" and apply a coating or separator sheet for corrosion resistance (See Drawing A- 4).

For A or B:

1. When using valley metal with returns, secure with clips fabricated from similar or compatible material. Clip 1" metal edge returns to either deck or batten strip with roofing nail through metal strap.
2. Trim metal at all valley/ridge junctions, ensuring water shedding capabilities onto the valley.
3. Install lead soaker at all valley/ridge junctions. Turn lead up a minimum of 1" to create a water diverter, ensuring water shedding capabilities onto the valley.

DRAWING A-3

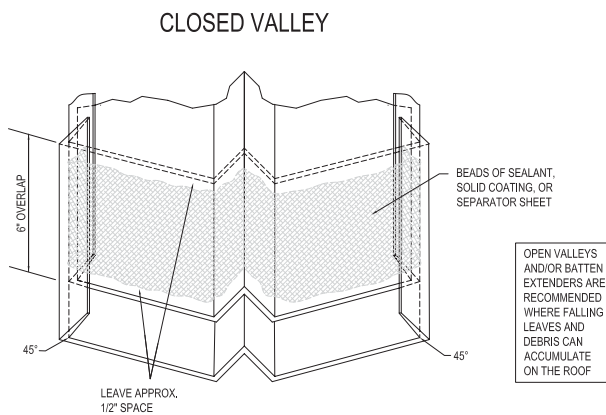

DRAWING A-4

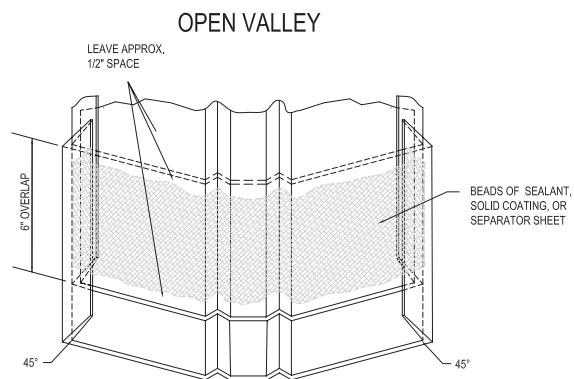

3.06 Valley or Wall Flashings Termination onto Roof Plane

A. When valley or wall flashing terminates onto roof plane install in accordance with valley flashing procedures in section 3.05 and/or 3.07 respectively.

1. Apply a lead soaker/skirt underneath the eave end of valley or wall flashing to carry water off the valley/wall flashing back onto the field tile (See Drawing A-5).
2. If lead skirt is not used, extend length of valley metal to carry water off the valley back onto the field tile.

DRAWING A-5

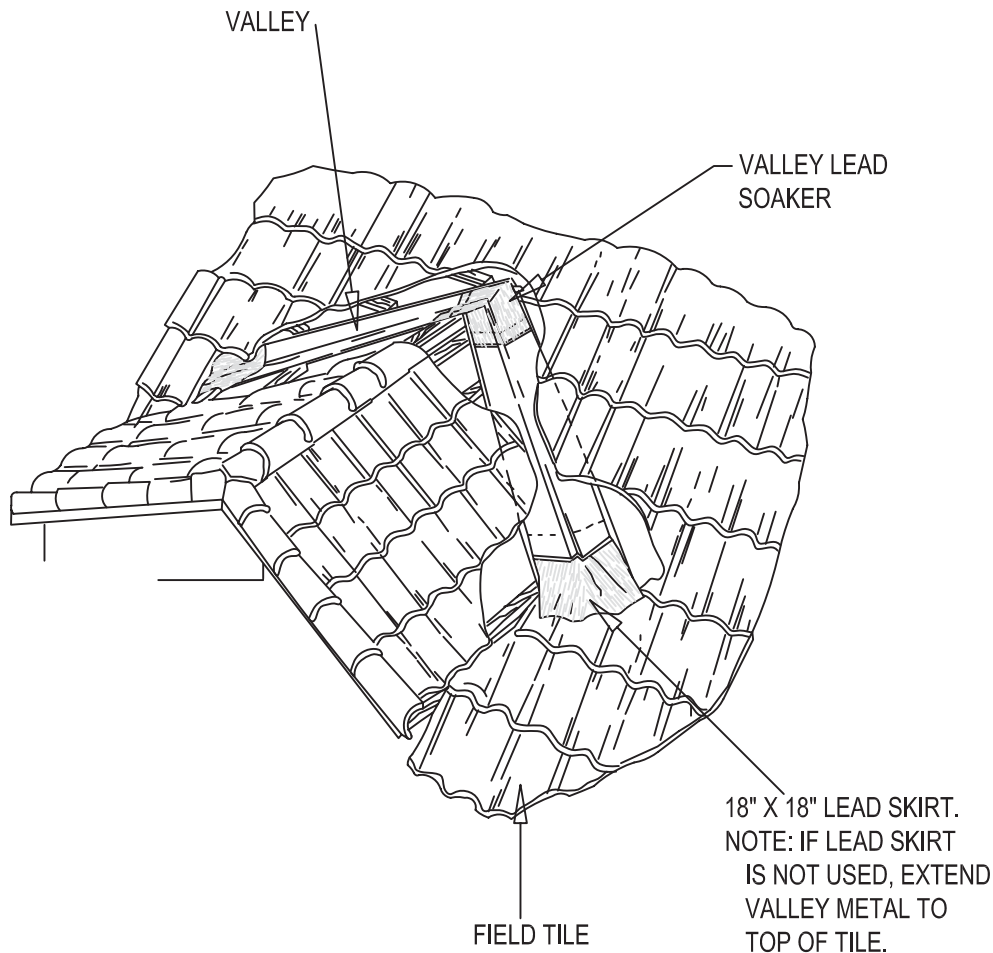

3.07 Flashing and Counter Flashings at all Abutments (See Drawing A-6)

- A. Install preformed metal wall tray 5" vertical flange, 6" base flange with 1" metal edge return flush to base of walls over underlayment. Start at lower portion and work up to ensure watertight application.
- B. Secure with clips fabricated from compatible material 24" on center. Clip 1" metal edge return to deck or batten strip with roofing nail through a metal strap.
- C. Nail vertical metal flange near outside edge. Secure as necessary to meet job conditions. Lap joints a minimum of 4" and apply flashing cement for corrosion resistance.
- D. On block walls, seal along entire edge of vertical metal flange, covering all nail penetrations with flashing cement and membrane.
- E. On frame walls, install vapor barrier over flashing.
- F. When installing optional counter flashing, lap top flange of base flashing a minimum of 4". Nail metal near the outside edge a minimum of 6" on center or set metal into reglets and seal thoroughly. Lap joints a minimum of 3" and apply flashing cement or sealant between the laps.

NOTE: Where special conditions exist, it may be necessary to increase the width of the valley metal and/or pan flashing.

DRAWING A-6

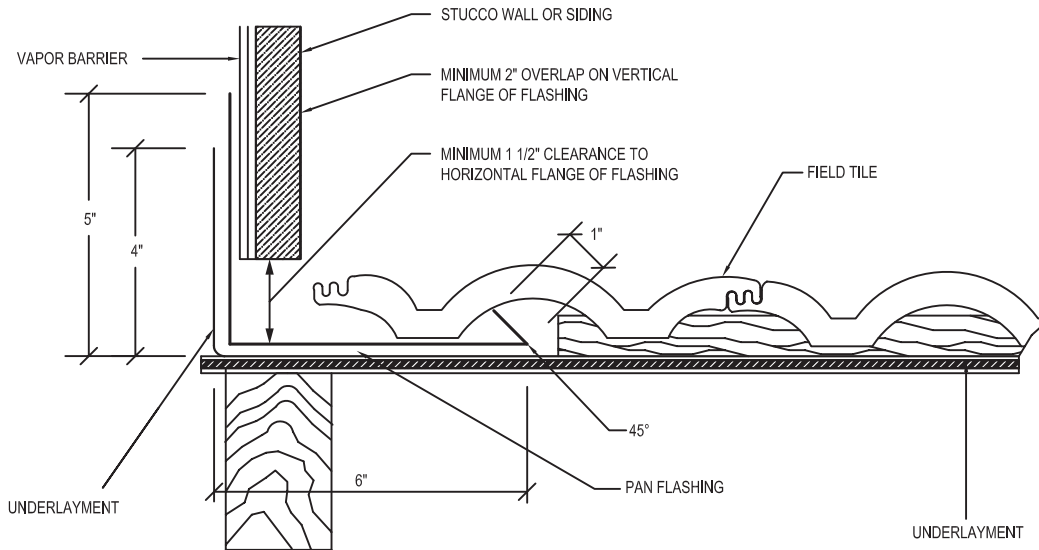

NOTE: THE FLASHING DIMENSIONS SHOWN ABOVE MAY VARY IN ACCORDANCE WITH THE BUILDING CODE, LOCAL BUILDER AND/OR SUB-CONTRACTOR PRACTICE AND LOCAL WEATHER CONDITIONS. ALL FLASHING MUST BE DESIGNED AND INSTALLED TO BE WATERTIGHT

3.08 Head & Apron Flashing (See Drawings A-7, A-8 & A-9)

A. Install apron flashing a minimum 4" on tile surface. Nail vertical flange of flashing within 1" of metal edge and secure as necessary. Lap metal 6". Seal laps with flashing cement.

3.09 Standard Curb Mounted Skylights, Chimneys, Etc. (See Drawing A-10)

- A. Curbs shall be a minimum 2" x 6", and a minimum of 1-1/2" above the tile height.
- B. Install a minimum 12" width lead at eave end of each curb.
- C. Secure with fasteners 6" on center, insuring nails will be covered by skylight/hood vent flange.
- D. Continue with flexible or rigid flashing on both sides of the curb working up toward ridge. Trim as necessary to ensure water shedding onto field tile.
- E. Secure with roofing fasteners 6" on center.
- F. Install flexible or rigid flashing on ridge end of curb.
- G. Seal all nail penetrations, at skylight or hood vent joints with sealant.

NOTE: For self curbing or prefabricated skylights refer to skylight manufacturer's instructions.

DRAWING A-7

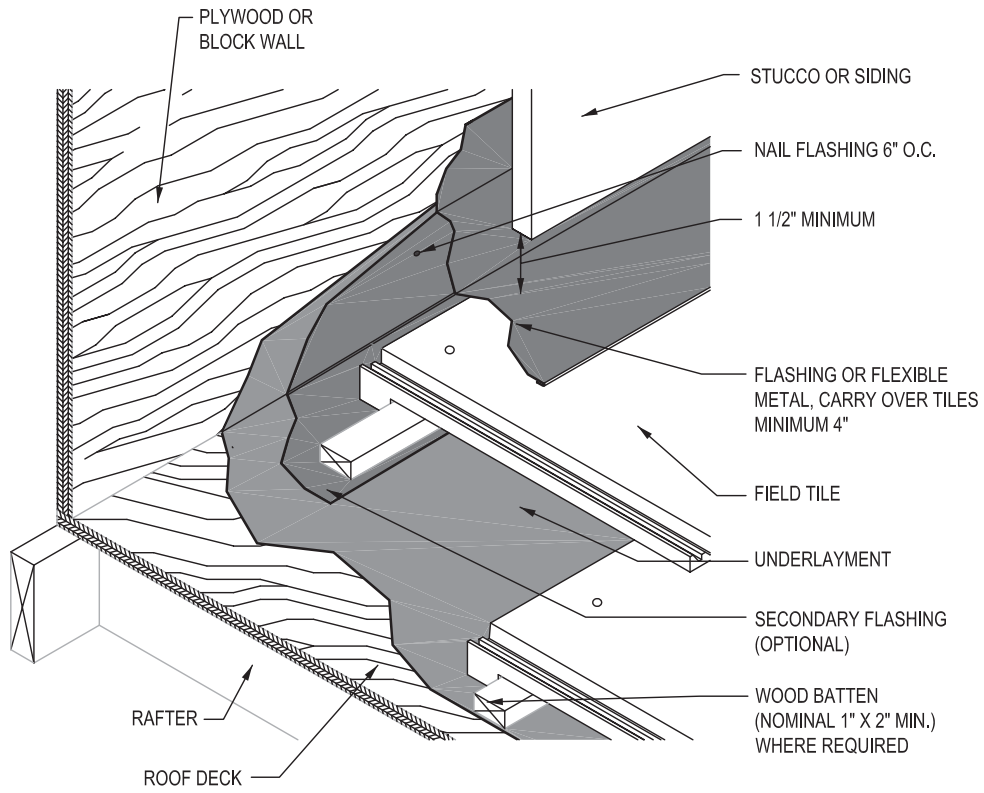

DRAWING A-8

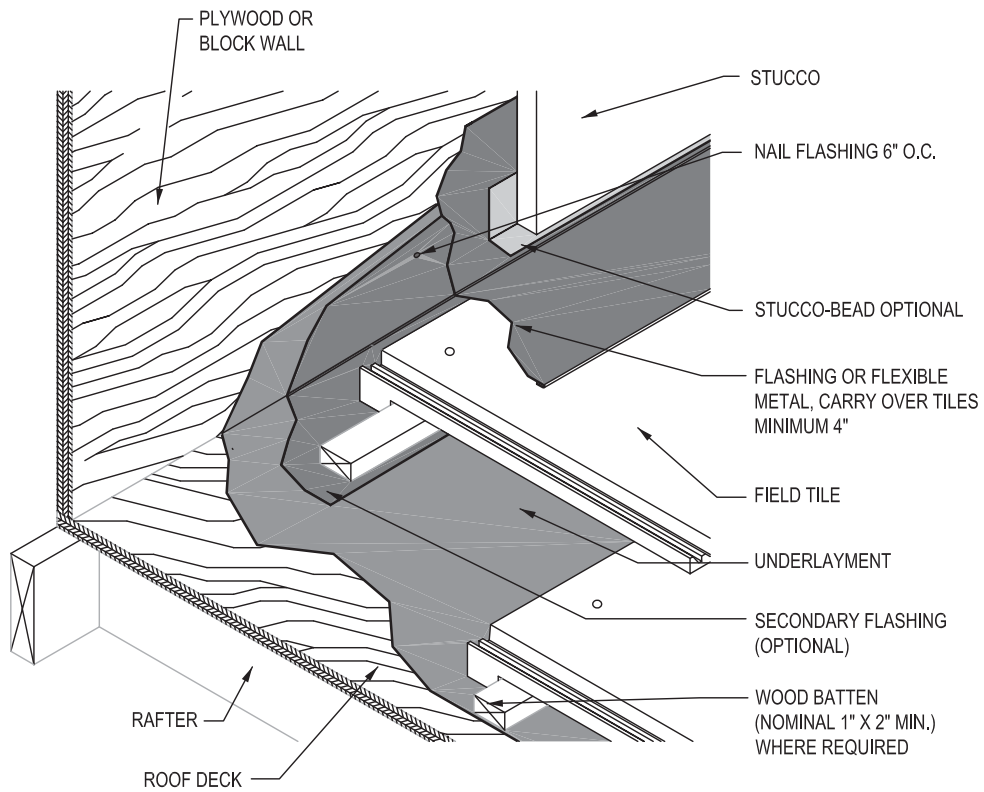

DRAWING A-9

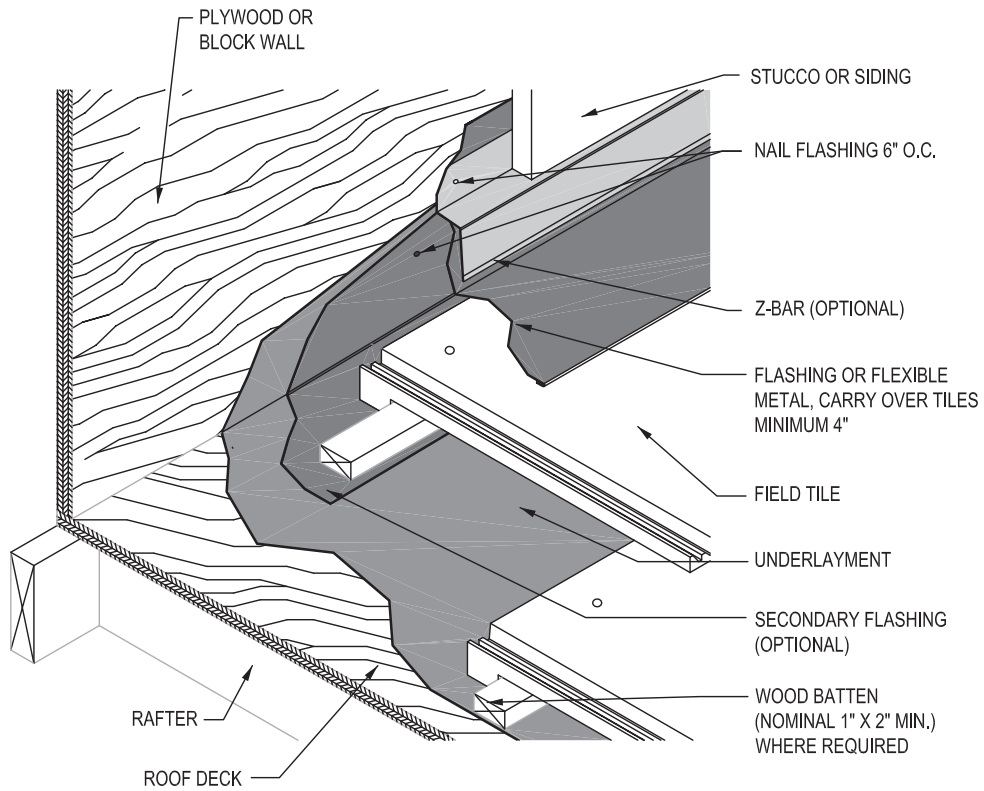

DRAWING A-10

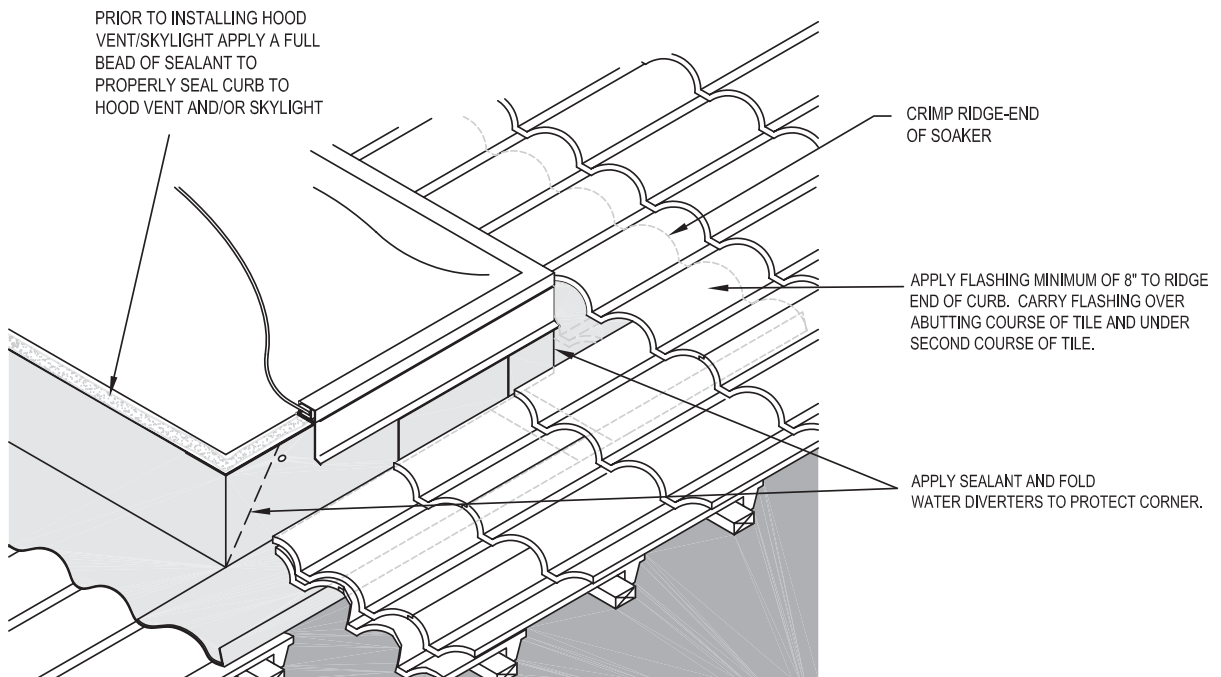

3.10 Pipes, Turbines, Vents, Etc.

A. Top Flashing on Tile (See Drawings A-11, A-12 & A-13).

- 1. Seal around penetration with flashing cement.
- 2. Apply skirt flashing over last field tile cut previously installed extending under the course of tile above penetration. Insure flashing is of sufficient width to redirect the water away from the penetration.
- 3. Seal flashing to tile with sealants as needed

NOTE: Profile specific ventilators should be installed as per manufacturer’s installation instructions.

DRAWING A-11

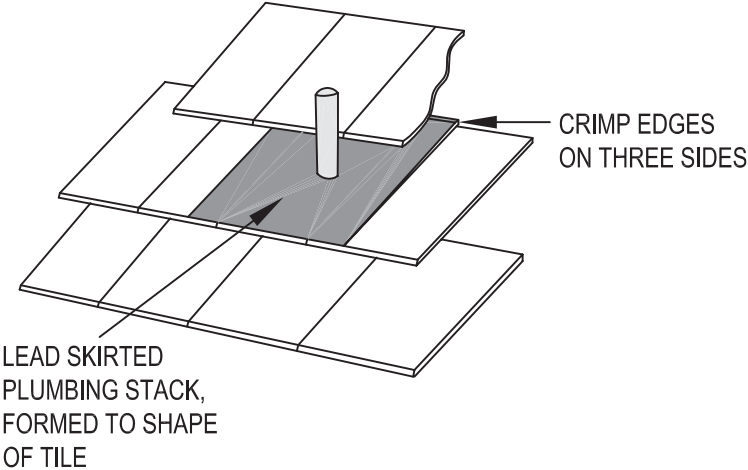

DRAWING A-12

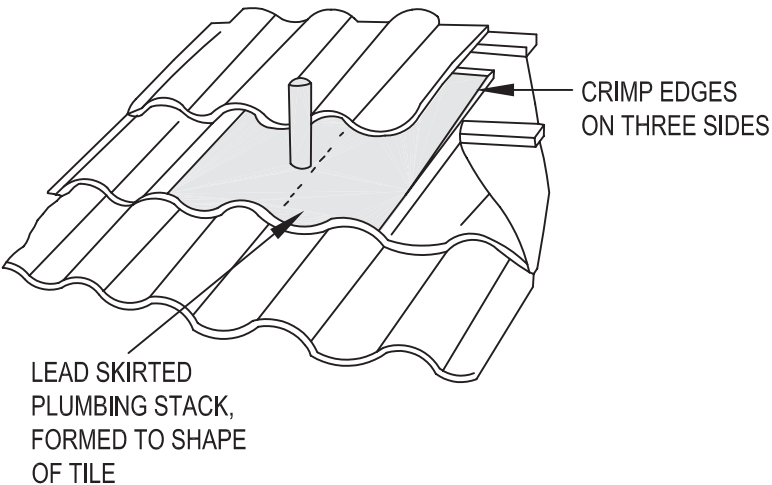

DRAWING A-13

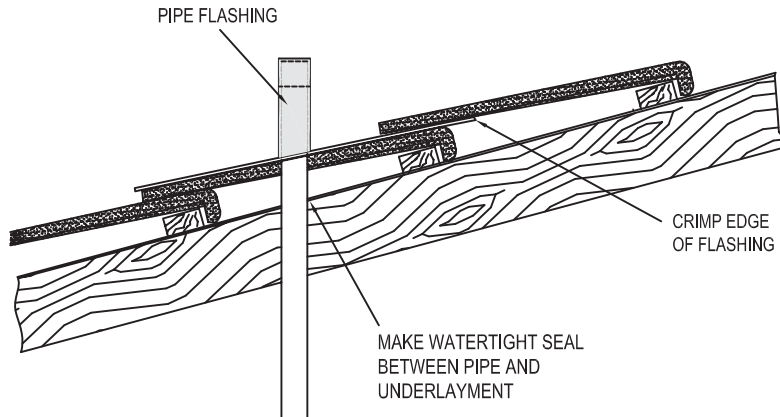

3.11 Batten Installation (See Drawing A-14)

NOTE: Horizontal battens shall be a minimum of 4' in length. When utilizing battens, preformed metal flashing with metal edge returns must be used in addition to a 3" tile head lap (unless restricted by product design). Battens are not allowed below a 4":12" slopes and are optional for slopes 4":12" and above.

- A. Install top edge of horizontal batten to horizontal line. Horizontal battens may be a minimum nominal 1" x 2".
- B. Fasten and secure maximum 24" on center with nails or screws of sufficient length to penetrate the sheathing a minimum of 3/4".
- C. Leave 1/2" space between batten ends and between batten and metal edge return.

DRAWING A-14

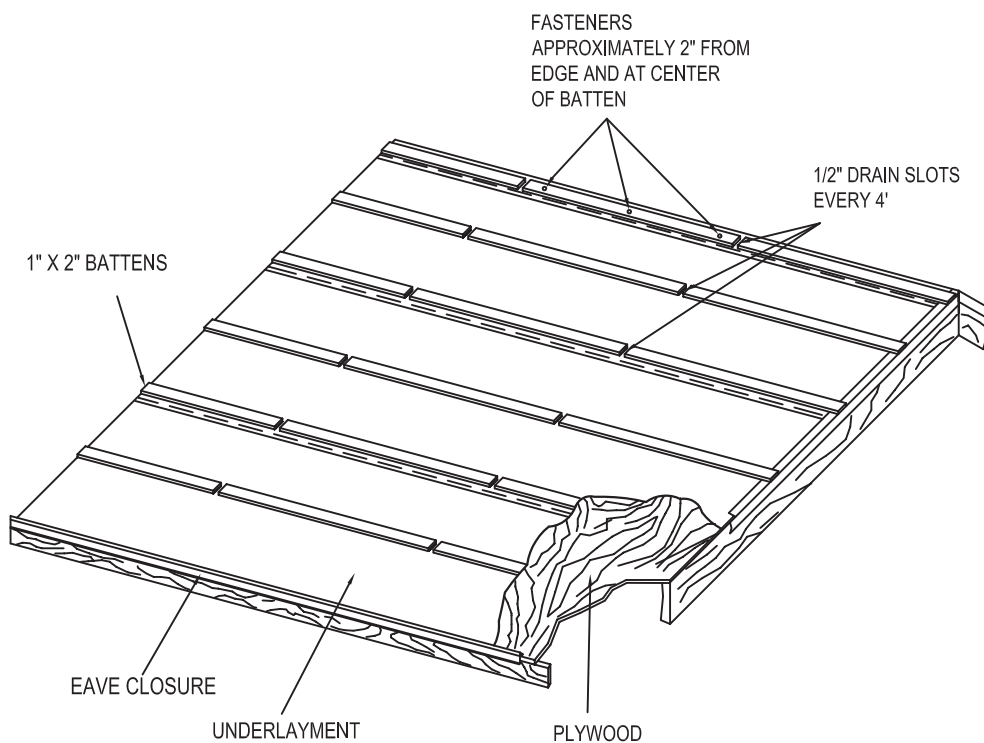

System Four

Adhesive-Set Tile Guidelines Underlayment Option “B”

NOTE: The following table provides the contractor with the choices available for underlayment systems. These systems can only be used on pitches designated in the table below:

Slope of Roof	Direct Deck	Choice of Underlayments	Plastic or Compatible Cement at Fasteners Penetrating Underlayments	Reference
2”: 12” and greater	Direct Deck	1. Hot Mop No.30 or No.43/90# Organic or Modified Cap Sheet	Required	3.02A
2”: 12” and greater	Direct Deck	2. Cold Process No.30 or No.43/90# Organic or Modified Cap Sheet	Required	3.02B
2”: 12” and greater	Direct Deck	3. Self-Adhered Underlayment - Applied Direct to Wood Deck	See note below	3.02C
2”: 12” and greater	Direct Deck	4. No.30/Self-Adhered Underlayment	See note below	3.02D
As tested	Direct Deck	5. Alternative Membranes	See note below	3.02E

NOTE: Refer to underlayment manufacturer’s recommendations.

System #4 - Option “B”

3.02 Underlayment Application - Choose one of the following:

NOTE: On cap sheet, cut fishmouths and seal with compatible flashing cement and membrane where applicable.

NOTE: Anchor sheet fastening shall be in accordance with Anchor Sheets Fastening Tables 1 to 5C.

NOTE: Anchor sheet shall be a minimum 2-plys in the valley.

NOTE: A No.15, No.30 or No.43 can be used as a dry in prior to installing the underlayment with this system (except on 3.02 C).

A. Hot Mop Application - No.30 or No.43 / 90# Organic or Modified Cap Sheet (See Drawing B-1)
A two ply roof application commonly called a ‘Hot Mop’ system. The roof cover is terminated at metal flashings. A No.30 or No.43 anchor sheet shall be mechanically attached to the wood deck with nails and tin caps, round cap nails or other fasteners spaced according to Anchor Sheets Fastening Tables 1 to 5C. Extend anchor sheet a minimum of 4” up vertical surfaces. Anchor sheet side laps shall be a minimum of 6” and head laps shall be a minimum of 2”. Over installed anchor sheet, apply the cap sheet with an application rate of 25 #/sq. ± 15% mopping of asphalt. With this system the cap sheet may come in contact with the base sheet, allowing felt to touch felt. Side laps shall be a minimum of 6”; head laps shall be a minimum of 3” and back nailed 12” on center.

B. Cold Process Application - No.30 or No.43/90# Organic or Modified Cap Sheet (See Drawing B-1)
A two ply roof application commonly called a ‘Cold Process’ system. A No.30 or No.43 anchor sheet shall be mechanically attached to the wood deck with nails and tin caps, round cap nails or other fasteners spaced according to Anchor Sheets Fastening Tables 1 to 5C. Extend anchor sheet a minimum of 4” up vertical surfaces. Anchors sheet side laps shall be a minimum of 6” and head laps shall be a minimum of 2”. Over installed anchor sheet, apply the cap sheet in a continuous layer of cold process adhesive at the rate of 1.5 gal/sq. or according to underlayment/adhesive manufacturers recommendation. Cap sheet side laps shall be a minimum of 6”; head laps shall be a minimum of 3” and back nailed 12” on center.

NOTE: For Cold Process Systems, in windy conditions, it may be necessary to spot nail cap sheet at laps at a maximum of 3’ on center.

C. Self-Adhered Underlayment - Applied Direct to Wood Deck.

A single ply underlayment system utilizing self-adhered underlayment. Apply one layer of self-adhered underlayment in compliance with the self-adhered underlayment manufacturers’ recommendations.

D. No.30/Self-Adhered Underlayment

A two ply roof application utilizing a self-adhered underlayment. No.30 felt shall be mechanically attached to the wood deck with nails and tin caps, round cap nails or other fasteners spaced according to Anchor Sheets Fastening Tables 1 to 5C. Extend anchor sheet a minimum of 4” up vertical surfaces. Anchor sheet side laps shall be a minimum of 6” and head laps shall be a minimum of 2”. Over installed anchor sheet, apply one layer of a self-adhered underlayment in compliance with the self-adhered underlayment manufacturers’ recommendation.

E. Alternative Membranes

Any product consisting of one or more water shedding layers applied to a sloped roof prior to the application of a prepared roof covering having been tested in compliance with the building code. The primary purpose of an underlayment is defined as a water shedding layer to function in combination with a prepared roof covering.

- 3.03 Eave Drip Metal - Choose one of the following: (For anti-ponding metal, see Section 4.02 B.3).
- A. Drip edge metal shall be installed over anchor sheet, fastened 6” on center with 12 ga. corrosion resistant roof nails or fasteners of compatible metals. All joints shall be lapped a minimum of 2”. Continue from eave up rake/gable in same manner, ensuring water shedding capabilities of all metal laps. The cap sheet shall be bonded to the metal with asphaltic adhesive.

DRAWING B-1

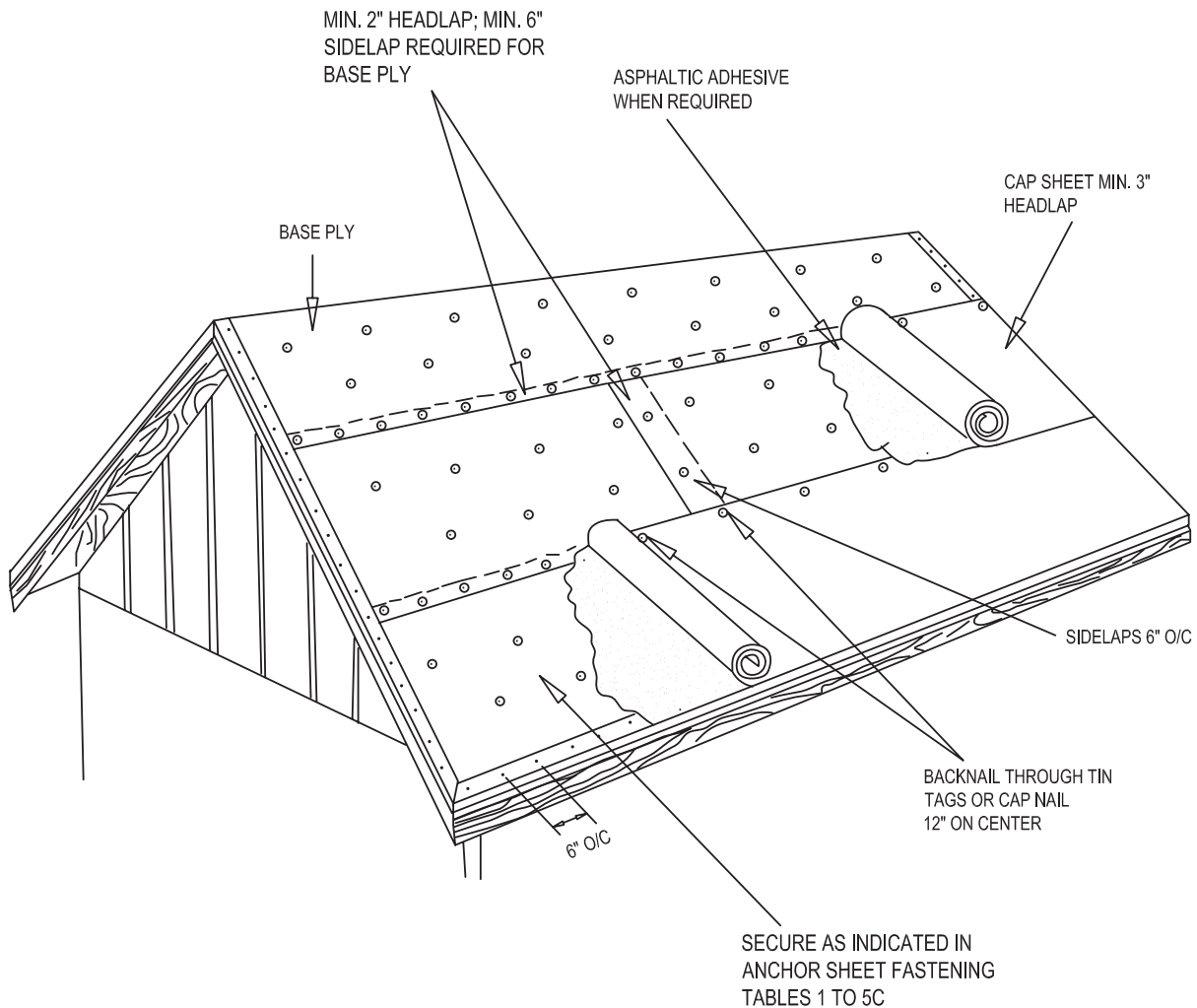

or,

- B. Drip edge metal shall be installed at eave over the finished cap sheet. The metal shall be fastened 6” on center with 12 ga. corrosion resistant roof nails or fasteners of compatible metals. All joints shall be lapped a minimum of 2”. The metal and underlayment shall be joined with a bed of flashing cement and a 4” strip of asphalt saturated cotton or fiberglass fabric. The fabric shall be fully embedded in the flashing cement.

- 3.04 Valleys - Choose one of the following: (See Drawings B-2, B-3, B-4)

NOTE: Outer edge of the valley metal shall overlap deck flange of drip edge a minimum of 1”. Center of valley flashing shall extend a minimum of 2” beyond drip edge.

- NOTE:** Preformed valley metal shall be either a minimum width of 16” (24” stretch out) with a minimum 2 1/2” high center diverter or a ribbed design with 1” center diverter, a minimum four (4) 3/8” bibs spaced 3 1/2” with a 3 3/4” flange.
- A. Two Ply System - Choose one of the following:
1. Standard Roll Metal - minimum width of 16”, shall be placed over the anchor sheet in the valley and shall be fastened 6” on center with 12 gauge corrosion resistant roofing nails, or other fasteners of compatible metals near the outside edge of the valley metal. All joints shall be lapped a minimum of 6” in a bed of flashing cement. The cap sheet shall be bonded to the metal with asphaltic adhesive (See Drawing B-5).
or,
 2. Preformed metal without returns - minimum 16” wide, shall be placed over the anchor sheet in the valley and shall fastened 6” on center with 12 gauge corrosion resistant roofing nails, or other fasteners of compatible metals near the outside edge of the valley metal. All joints shall be lapped a minimum of 6” in a bed of flashing cement. The cap sheet shall be bonded to the metal with asphaltic adhesive (See Drawings B-6).
- B. Over Cap Sheet - Choose one of the following:
1. Standard Roll Metal - minimum 16” wide shall be placed over the cap sheet in the valley and shall be fastened 6” on center with 12 gauge corrosion resistant roofing nails, or other fasteners of compatible metals near the outside edge of the valley metal. All joints shall be lapped a minimum of 6” in a bed of flashing cement. The cap sheet shall be joined with a bed of flashing cement and a 4” strip of asphalt saturated cotton or fiberglass fabric. The fabric shall be fully embedded in the flashing cement.
or,
 2. Preformed Metal Without Returns -minimum 16” wide shall be placed over the anchor sheet in the valley and shall be fastened 6” on center with 12 gauge corrosion resistant roofing nails, or other fasteners of compatible metals near the outside edge of the valley metal. All joints shall be lapped a minimum of 6” in a bed of flashing cement. The cap sheet shall be joined with a bed of flashing cement and a 4” strip of asphalt saturated cotton or fiberglass fabric. The fabric shall be fully embedded in the flashing cement.

DRAWING B-2

PREFORMED CLOSED VALLEY METAL

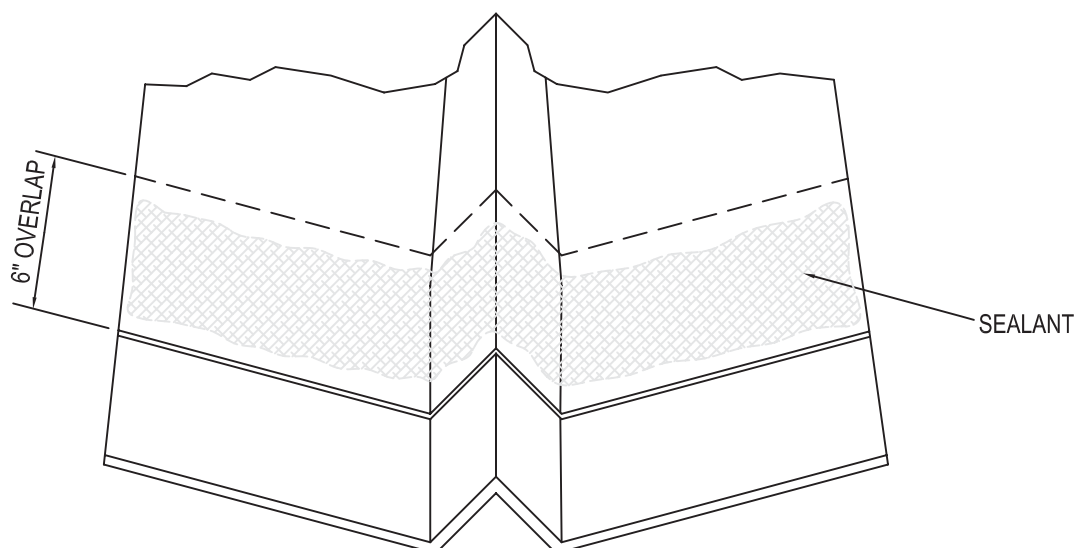

DRAWING B-3

PREFORMED CLOSED VALLEY METAL

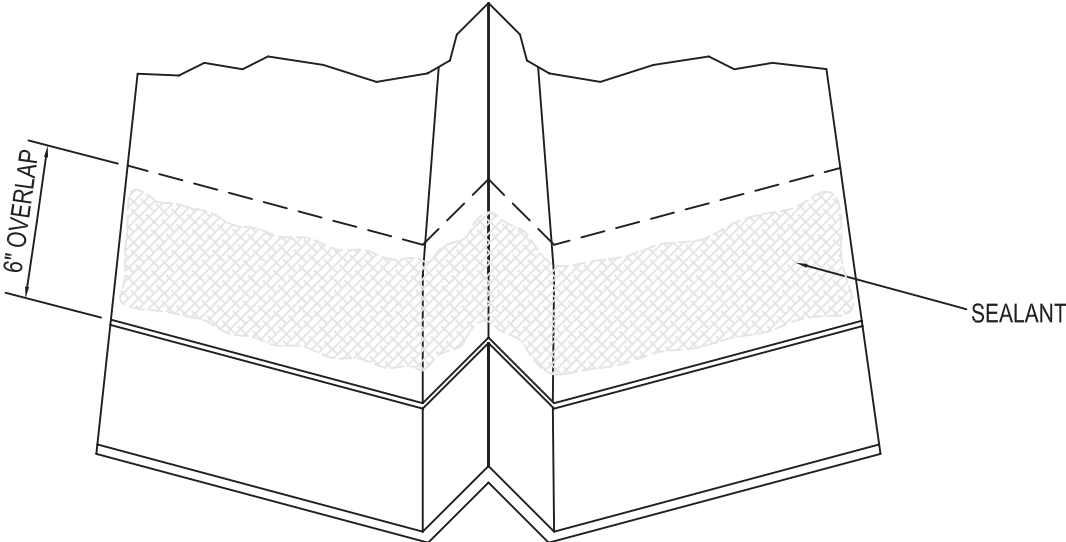

DRAWING B-4

ROLL VALLEY METAL

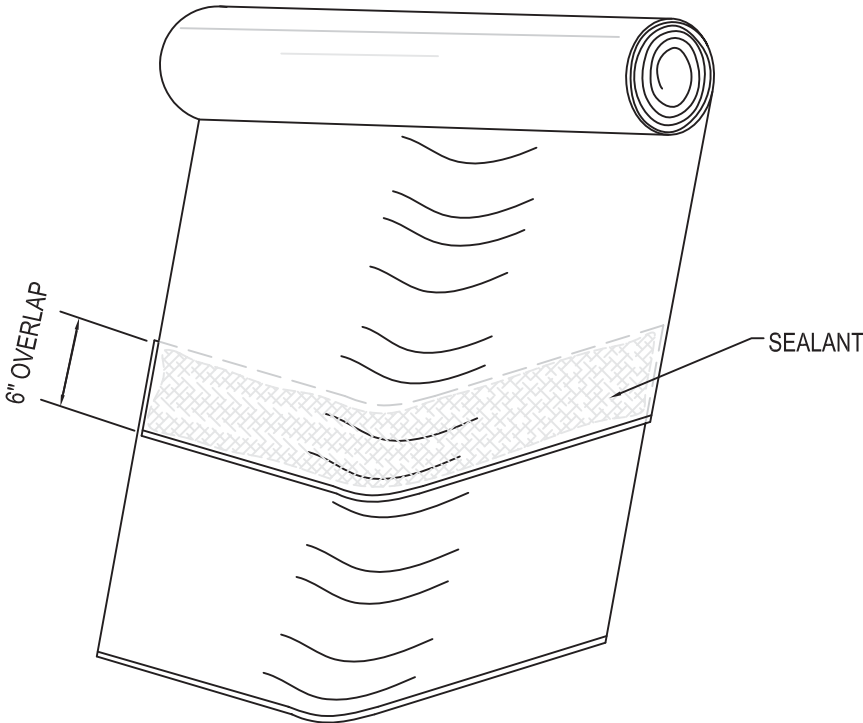

3.05 Flashing and Counter Flashing at Wall Abutments - choose one of the following:

A. Two Ply System

1. Install 4"x 5" "L" flashing flush to base of walls with 4" flange on the anchor sheet.
2. Fasten 6" on center with 12 ga. corrosion resistant nails or other fasteners of compatible metals near the outside edges of metal.
3. Lap joints 4" and apply flashing cement between laps.
4. The cap sheet shall be bonded to the metal with asphaltic adhesive. (See Drawings B-6, B-9 & B-10).

or,

B. Over Cap Sheet

1. Install 4"x 5" "L" flashing flush to base of walls with 4" flange on top of cap sheet.
2. Fasten 6" on center with 12 ga. corrosion resistant nails or other fasteners of compatible metals near the outside edges of metal.
3. Lap joints 4" and apply flashing cement between laps.
4. Cap sheet shall be joined to the "L" flashing with flashing cement and a minimum 4" strip of asphalt saturated cotton or fiberglass fabric. The fabric shall be fully embedded in the flashing cement. (See Drawing B-7 & B-8).

C. Seal along top edge of vertical flange, covering all nail penetrations with flashing cement and membrane where required.

D. When installing optional counter flashing, lap top flange of base flashing minimum 4". Nail metal near the outside edge a minimum of 6" on center or set into reglets (secure properly) and thoroughly caulk. Lap joints minimum 3" and apply flashing cement between laps.

DRAWING B-5

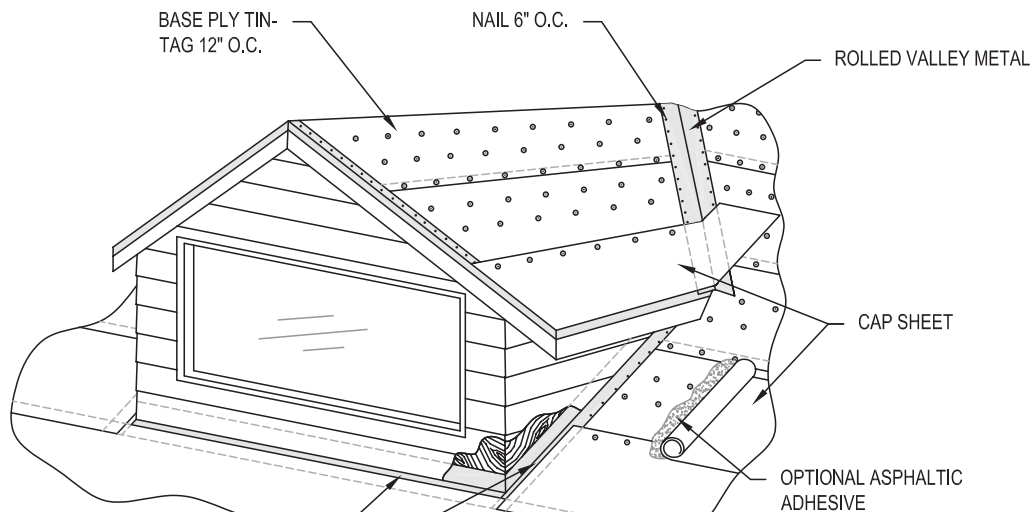

NOTE:
KEEP CAP SHEET APPROXIMATELY
1" FROM ABUTMENTS. FILL AREA
WITH PLASTIC CEMENT OR HOT
ASPHALT.

DRAWING B-6

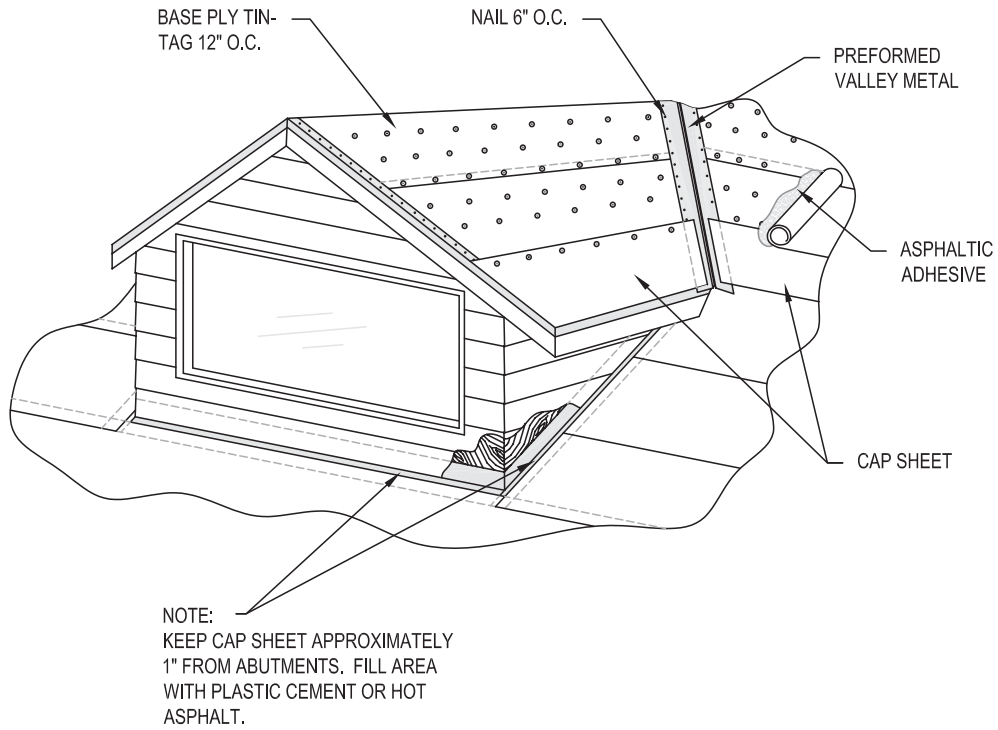

DRAWING B-7

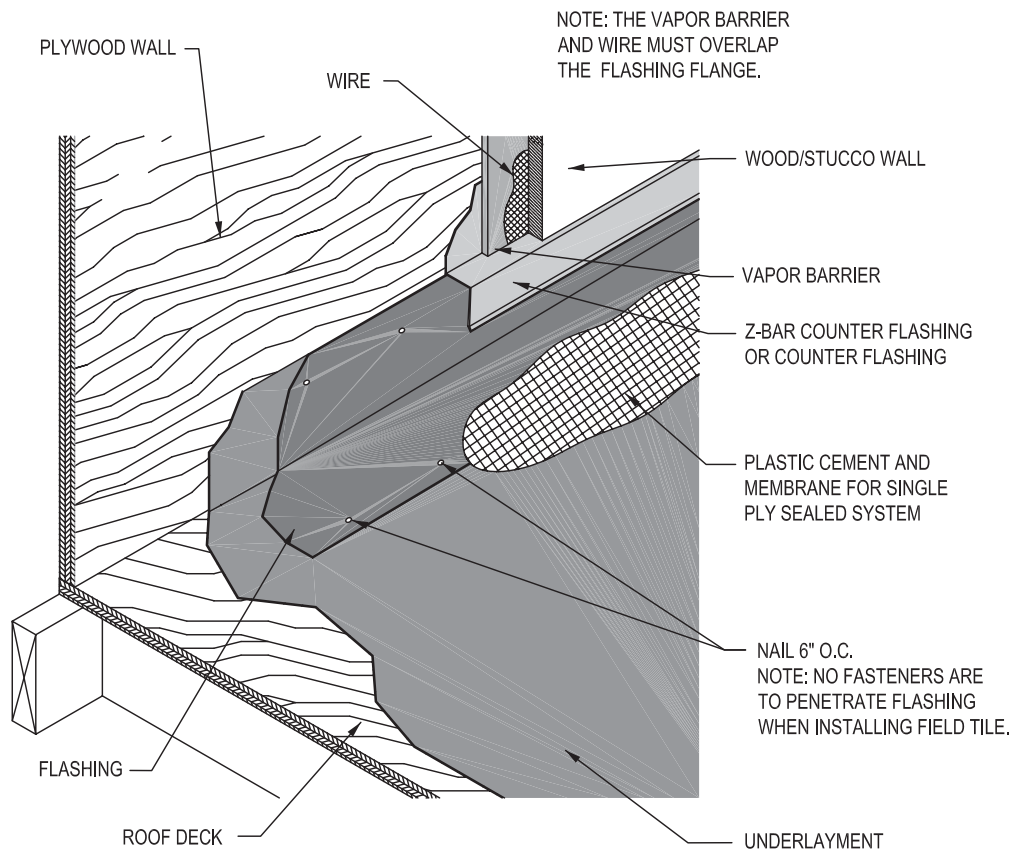

DRAWING B-8

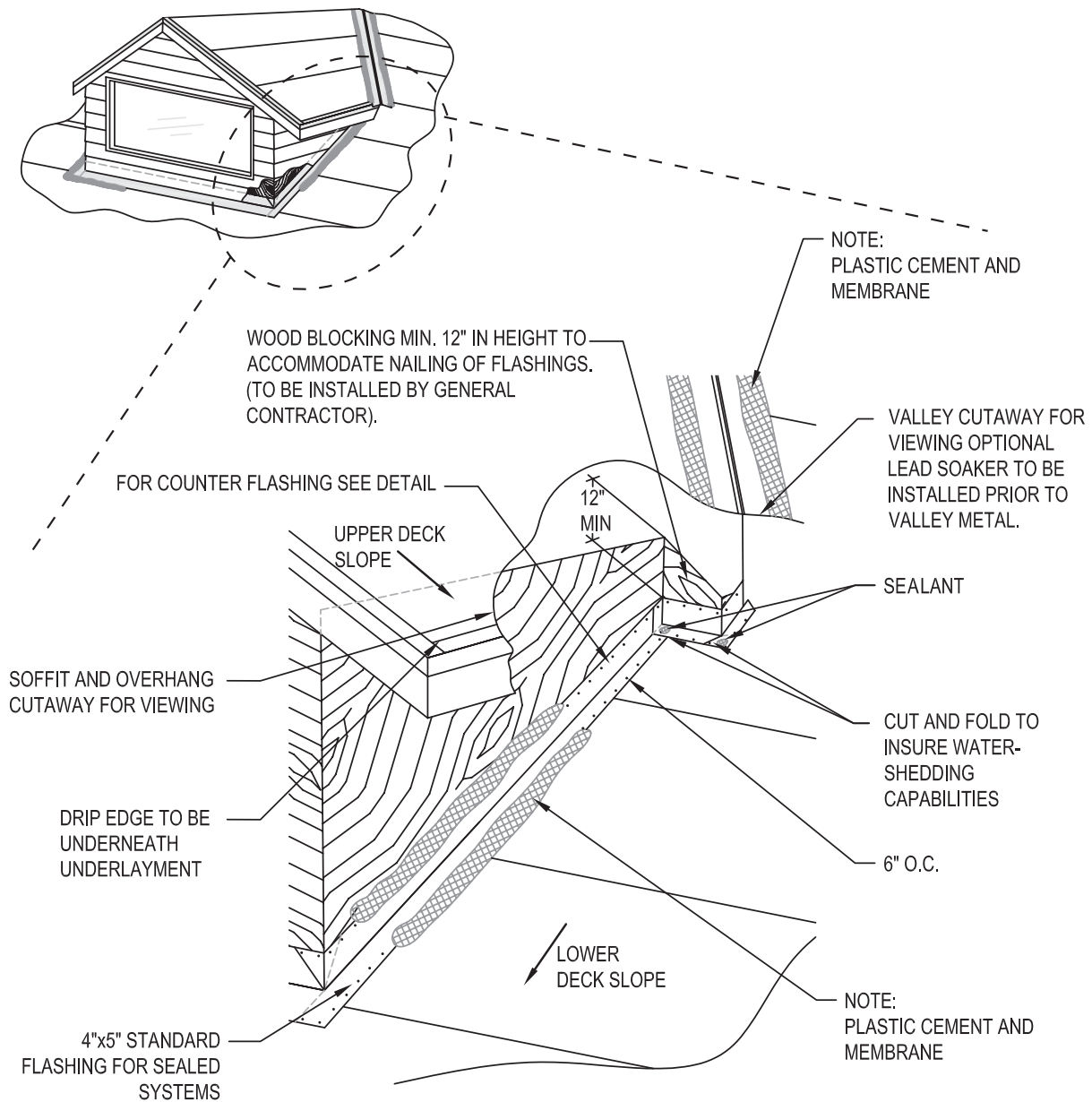

3.06 Standard Curb Mounted Skylights, Chimneys, Etc. (See 3.05 above)

A. Install in compliance with regular flashing installation procedures.

NOTE: For self curbing or prefabricated skylights, refer to skylight manufacturer's installation instructions.

3.07 Pipes, Turbines, Vents, Etc. - Choose one of the following:

A. Two-Ply System (See Drawings B-11, B-12, & B-13).

1. Apply flashing cement around base of protrusion and on the bottom side of the metal flanges sealing the unit base flashing to anchor sheet.
 2. Nail and secure all sides of base flashing. Make certain base is flush to deck.
- or,

- B. Over Cap Sheet (See Drawing B-14)
 - 1. Install unit base flashing over cap sheet.
 - 2. Nail and secure all sides of base flashing. Make certain base is flush to deck.
 - 3. Metal flange shall be joined to cap sheet with a bed of flashing cement and a strip of asphalt saturated cotton or fiberglass fabric. The fabric shall be fully embed in the flashing cement.
- C. Profile specific ventilators
 - 1. Shall be installed as per manufacturer's installation instructions.

DRAWING B-9

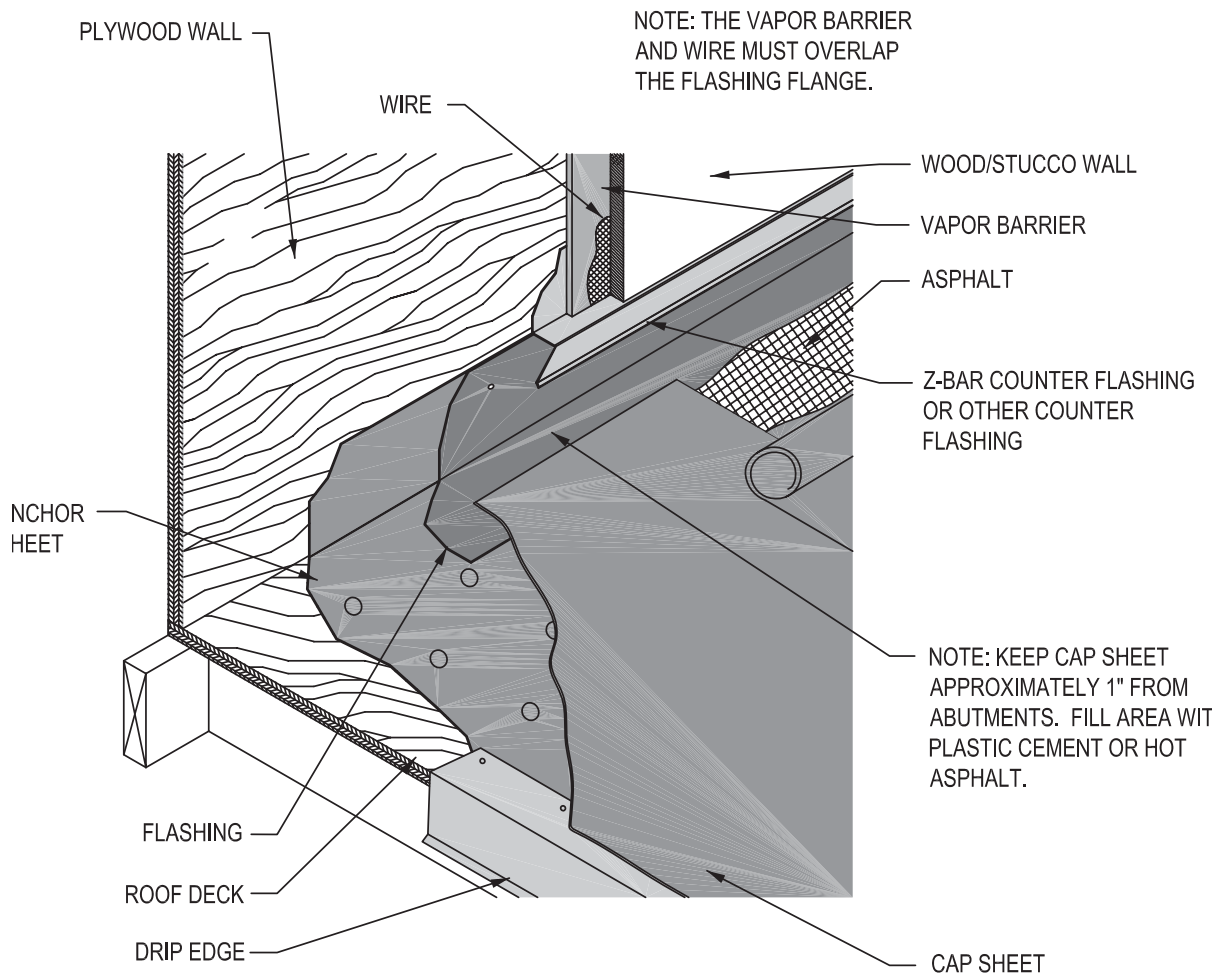

DRAWING B-10

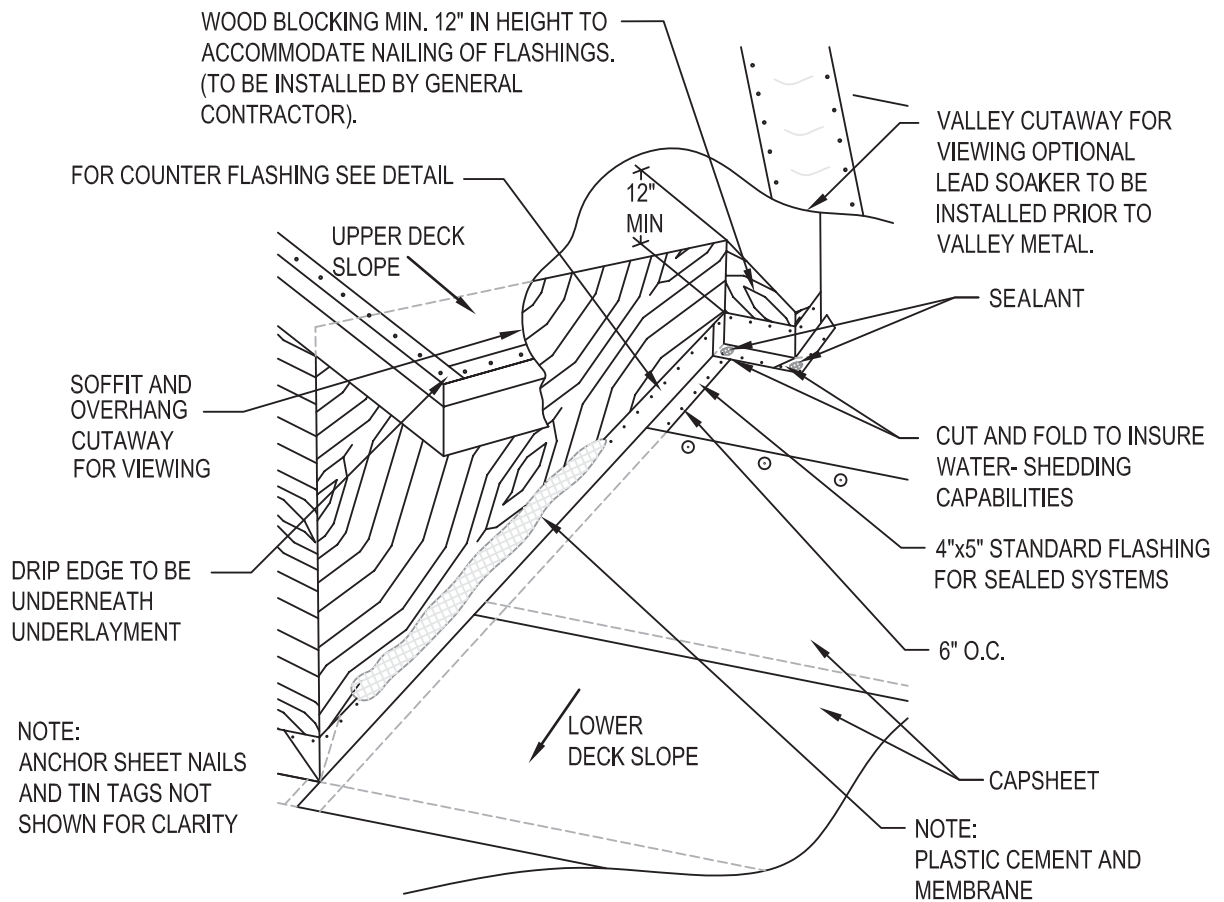
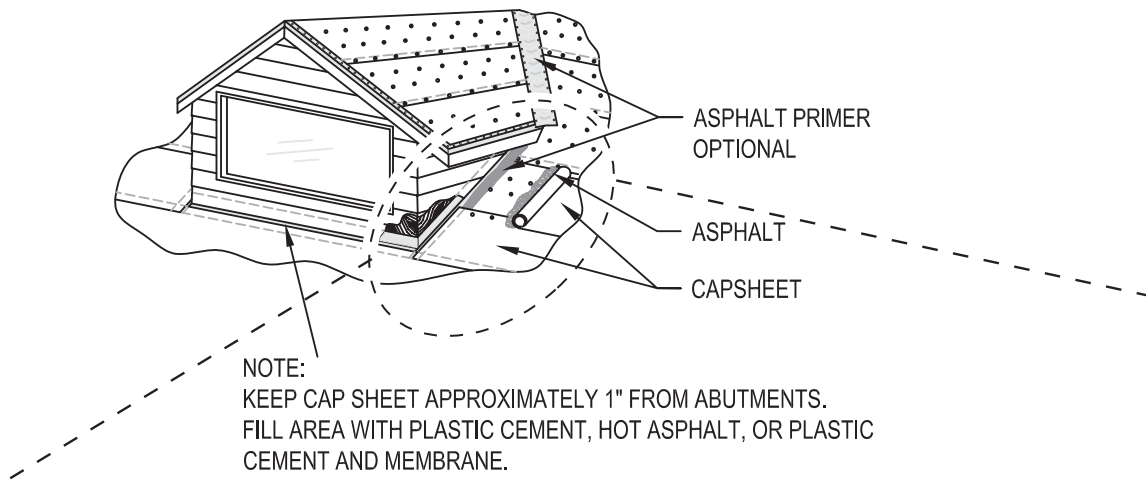

DRAWING B-11

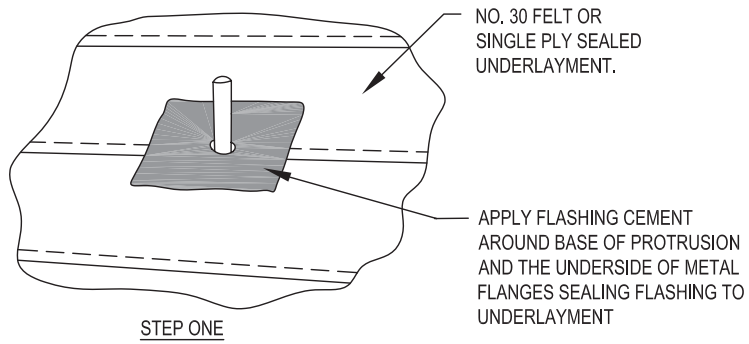

DRAWING B-12

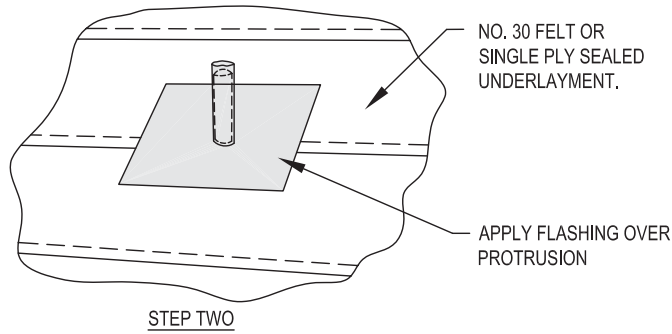

DRAWING B-13

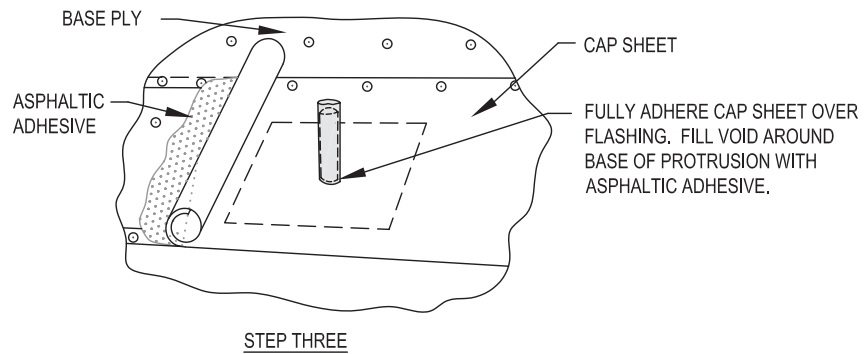

DRAWING B-14

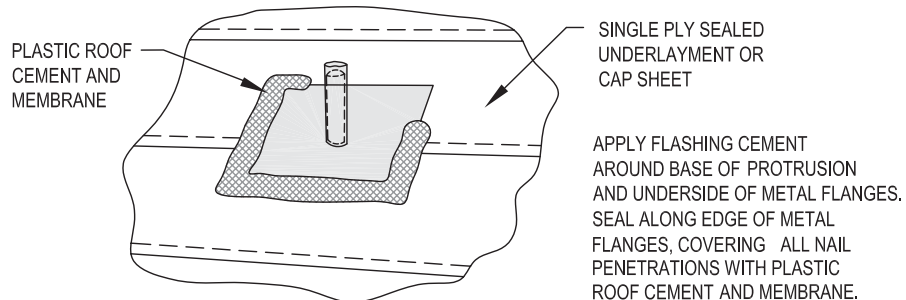

PART IV - TILE APPLICATION

4.01 Tile Layout

NOTE: When utilizing a single-ply mechanical fastened underlayment or when utilizing battens, a 3” tile head lap must be used (unless restricted by product design).

A. Layout - Horizontal (3” tile head laps or batten installation)

1. Chalk horizontal lines beginning one tile length from eave less desired overhang. Overhang shall be 3/4” to 2”, depending on the tile type, use of gutter, or other functional requirements.

NOTE: For batten installation only, chalk line 1 1/2” from ridge.

2. Chalk succeeding lines for a minimum 3” head lap unless restricted by product design.
3. Increase head lap when necessary for equal course spacing.

NOTE: When utilizing a single-ply peel and stick underlayment or a two-ply asphaltic adhesive underlayment system, a minimum 2” head lap may be used unless restricted or dictated by product design.

or,

B. Layout - Horizontal (for 2” head lap)

1. Chalk horizontal lines beginning one tile length from eave less desired overhang. Overhang shall be 3/4” to 2”, depending on tile type, use of gutter, or other functional requirements.
2. Chalk succeeding lines to accommodate a minimum 2” tile head lap unless restricted by product design.
3. Increase head lap when necessary for equal course spacing.

C. Layout - Vertical - choose one of the following:

1. Staggered/cross bond tile installation (Recommended for flat/low profile tile)
 - a. Gable end roof
 - i. Chalk vertical lines one full tile and one half tile width plus 1” to 2” from starting gable to accommodate rake tile.
or,
 - ii. Chalk vertical lines one full and one half tile width from starting gable to accommodate flush finish.
 - iii. Chalk additional lines, if necessary, to maintain alignment.

NOTE: Flush finish gable treatment can only be used when utilizing a single-ply peel and stick underlayment or a two-ply asphaltic adhesive underlayment system.

- b. Hip roof
 - i. Chalk vertical line 90 degrees from eave line.
 - ii. Chalk second line parallel to first to accommodate staggered/cross bonded tile.
 - iii. Chalk additional lines, if necessary, to maintain alignment.

or,

2. Straight bond tile installation (Not recommended for flat tile)
 - a. Gable end roof
 - i. Chalk vertical line one full tile width plus 1” to 2” from starting gable.
 - ii. Chalk additional lines, if necessary, to maintain alignment.
 - b. Hip roof
 - i. Chalk vertical lines, if necessary, to maintain alignment.
 - ii. Chalk additional lines, if necessary, to maintain alignment.

4.02 Tile Installation

- A. Stack tile to facilitate installation and minimize tile movement.
- B. Eave treatment - Choose one of the following:
 - 1. Prefabricated Rubber Eave Closure - Install closure strip along eave. Fasten with a minimum 3 fasteners per 36” strip (See Drawing 4.01) or,
 - 2. Metal Eave Closure - Install closure strip along eave. Fasten a minimum 18” on center. If metal closure is inclusive of the drip edge fasten 6” on center (See Drawing 4.02) or,
 - 3. Raised Fascia/Wood Starter Strip - When using a 3/4” raised fascia, a 2” x 2” wood starter strip must be installed behind fascia. The use of eave closure is required in a raised fascia system when using a medium or high profile tile.
 - a. Install fascia board approximately 1 1/2” above roof deck or a 2” x 2” wood starter strip at roof edge (See Drawing 4.03). Choose one of the following:
 - i. Install 8” tapered cant strip at eave behind fascia and/or starter strip to support metal flashing and ensure positive drainage when using drip edge. or
 - ii. Install a minimum 8” wide anti-ponding metal flashing to ensure positive drainage over fascia/starter strip. Nail top edge of flange onto roof. Tapered cant strip is optional when using anti-ponding metal.
 - b. Apply underlayment as per Underlayment System A or B Sections 3.02.
 - 4. Prefabricated concrete or clay eave closure. (Apply per manufacturer’s instructions.)
 - 5. Mortar Application - Install mortar to elevate eave edge of tile.
 - a. Apply mortar along the eave edge, applying enough mortar to elevate the eave end of the tile to be on profile with the remaining roof tiles.
 - b. Point and smooth finish flush to eave.
 - c. Apply a minimum 3/8” weep hole flush with the underlayment at the spacing of not less than one weep hole per tile.

DRAWING 4.01

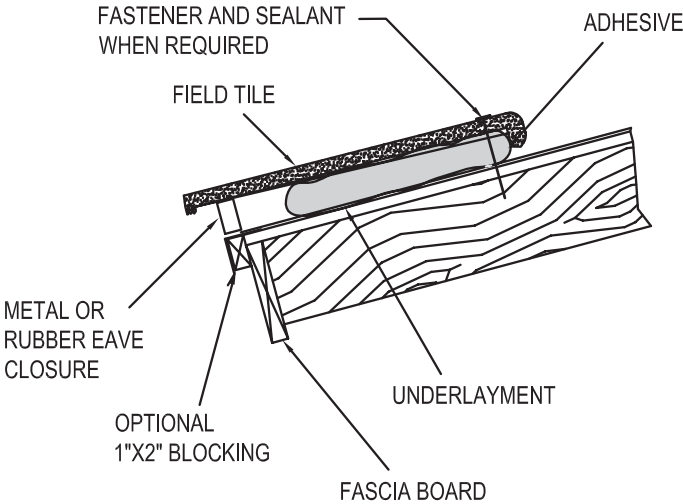

DRAWING 4.02

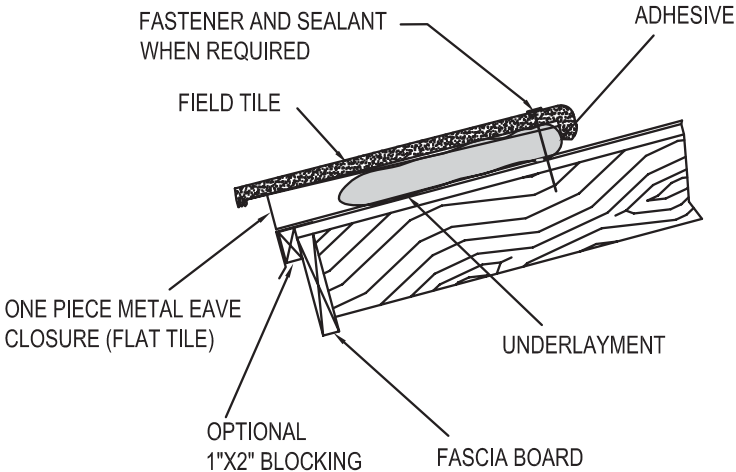

DRAWING 4.03

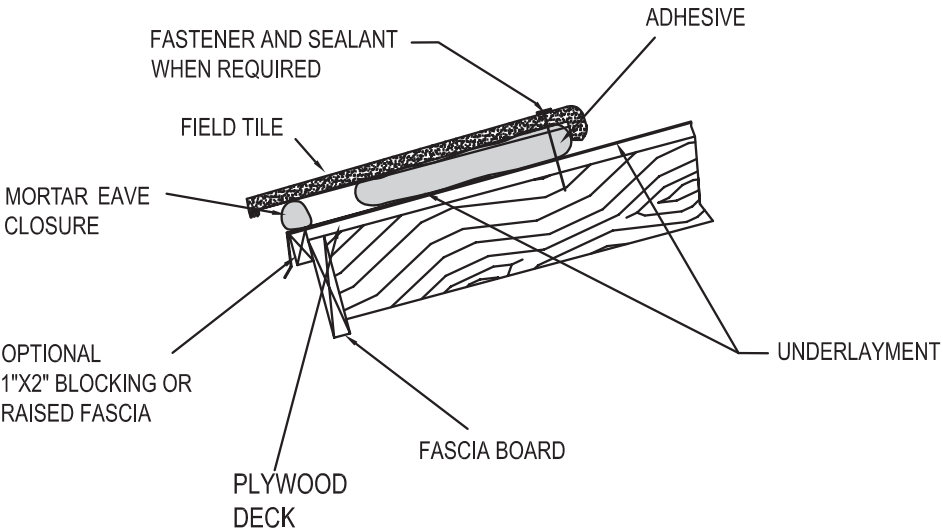

4.03 Flat / Low, Medium and High Profile Tile

- NOTE:** Adhesive set tile shall be applied at a pitch of 4":12" and higher for mechanically attached single-ply underlayment systems (Underlayment Option "A"), and at a slope of 2":12" and higher for self-adhered peel and stick underlayment systems or two-ply asphaltic adhesive underlayment systems (Underlayment Option "B").
- NOTE:** For slopes above 6":12" up to and including 7":12" fasten every tile in the first course and every third tile of the fifth course in addition to the tile adhesive. For slopes above 7":12" fasten every tile in addition to the tile adhesive. Apply compatible flashing cement to seal all fastener penetrations where required. When utilizing battens and tiles with batten lugs additional fastening is not required.
- NOTE:** Tile shall be attached to resist the aerodynamic moment determined when using the design pressures for the building and fixing calculations set forth in the building code.

Adhesive quantities and placement determine the total resistance values. Consult with specific adhesive manufacturer for installation instructions. Installations shall be based on tested methods as indicated in the compliance report, or product approval, listing the amounts, tested paddy placement and specific corresponding resistance values.

- A. Starting at the eave, install first course of tile according to the tile and adhesive manufacturer’s instructions. Make certain all tile overhangs drip edge evenly along entire first course.
- B. Install and secure all succeeding field, perimeter and corner tile according to the adhesive manufacturer’s instructions.
- C. Cut/break tile for proper staggering of tile courses when using the staggered/cross bond method of installation.
- D. Set tile in stepped course fashion or in a horizontal and/or vertical fashion when utilizing straight bond method.
- E. Cut/break field tile to form straight edge at center of hip/ridge and valleys.

4.04 Two Piece Barrel Tile (See Drawing 4.04)

NOTE: For slopes above 6”:12” up to and including 7”:12” fasten every pan tile in the first course and every 5th course thereafter in addition to the tile adhesive. For slopes above 7”:12” fasten every pan in addition to the tile adhesive. Apply compatible flashing cement to seal all fastener penetrations where required.

NOTE: Tile shall be attached to resist the aerodynamic moment determined when using the design pressures for the building and fixing calculations set forth in the building code. Adhesive quantities and placement determine the total resistance values. Consult with specific adhesive manufacturer’s instructions. Installations shall be based on tested methods as indicated in the compliance report, or product approval, listing the amounts, tested paddy placement and specific corresponding resistance values.

- A. Starting at the eaves, install first course of tile according to the tile and adhesive manufacturer’s instructions. Support of eaves pan tile if necessary, until the adhesive has a chance to cure. Make certain all tile overhangs drip edge evenly along entire first course.
- B. Install and secure all succeeding field, perimeter and corner tile according to the adhesive manufacturer’s instructions.
- C. Cut/break field tile to form straight edge at center of hip/ridge and valleys.

DRAWING 4.04

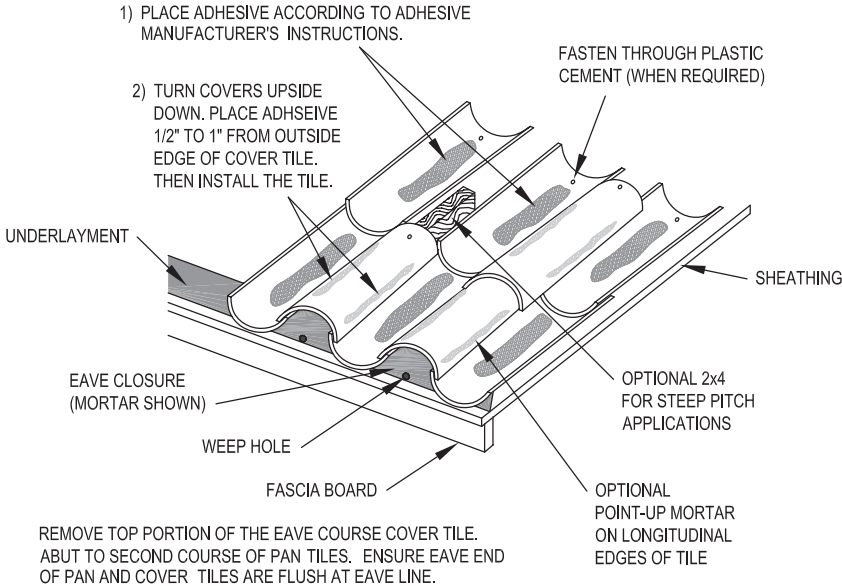

4.05 Valleys - Choose one of the following:

NOTE: It is not recommended to install trim tile in valleys. It may be necessary to remove the lugs from the field tile and/or install batten extended at walls and valley flashings for proper positioning of cut field tiles.

A. Standard Roll Valley (See Drawing 4.05) Choose one of the following:

- 1. Closed Valley - Miter tile to meet at the center of valley.
or,
- 2. Open Valley - Chalk a line minimum 2” on both sides of valley center. Place bed of mortar along outside of chalk lines. Miter tile to form straight border and point to match tile surface.
or,

B. Preformed Metals

- 1. Closed Valley - Miter tile to form straight border on either side of water diverter (See Drawing 4.06).
- 2. Open Valley - Miter tile to form straight border on either side of two water diverters (See Drawing 4.07).

DRAWING 4.05

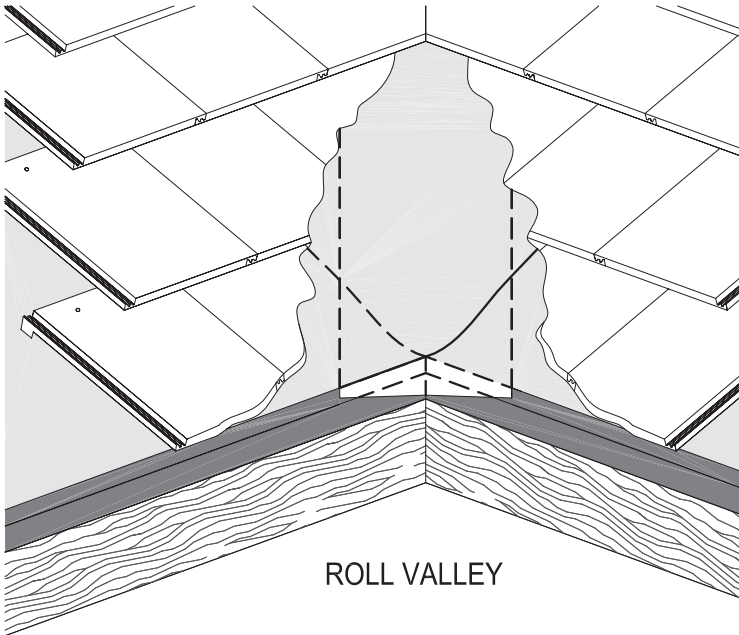

DRAWING 4.06

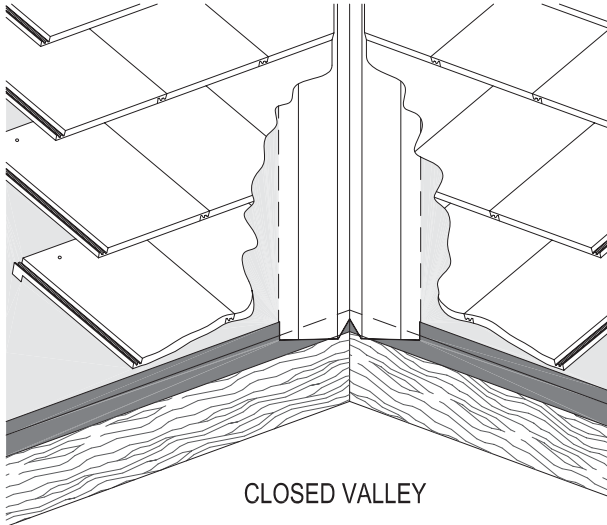

DRAWING 4.07

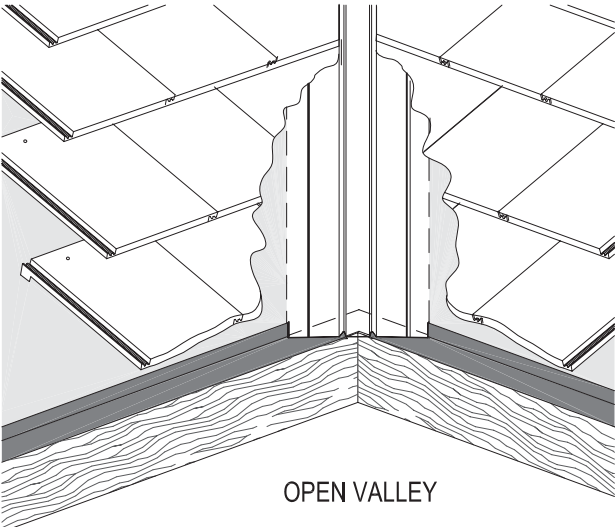

- 4.06 Hip and Ridge Nailers Boards – Refer to instructions for hip and ridge attachment.
- 4.07 Hip Starter - Refer to section on supplemental instructions for hip and ridge attachment.
- 4.08 Hip and Ridge Installation - Refer to instructions for hip and ridge attachment.
- 4.09 Rake/Gable Tile - Choose one of the following:
 - A. Rake/Gable Tile
 - 1. Install first rake tile to exposed length of first course of field tile with factory finish of rake tile towards the eave.

2. Fasten rake tile with minimum two 10D nails or screws of sufficient length to penetrate the framing a minimum of 3/4”.
3. Abut each succeeding rake tile to the nose of the field tile above and maintain a constant headlap.

or

B. Metal Finish

1. Install prefabricated gable metal with 1” water return.
2. Fasten by clipping 24” on center.

NOTE: Rake tile application at finishing end may need special consideration to provide proper drainage, i.e. flashing or sealant may be needed.

or

C. Mortar Finish

NOTE: Can be used with underlayment option “B” only.

1. Place mortar bed along roof edge.
2. Point smooth to a straight finish.

4.10 Wall Abutments

A. Cut tile to fit approximately 1/2” to base of walls.

NOTE: It may be necessary to remove the lugs from the field tile and/or install batten extenders at wall and valley flashing for proper positioning of cut field tiles and to facilitate water flow.

4.11 Plumbing Stacks

NOTE: For tile installations using Underlayment Option “A”, see Section 3.10 of that section for Plumbing Stack instructions. For tile installations using Underlayment Option “B”, see Section 3.07.

- A. Cut tile to fit close to plumbing stack.
- B. Fill void with mortar and point to finish.

4.12 Coatings - (optional)

- A. Sealer may be applied to exposed mortar.
- B. Color coordinated paint may be applied to all metal flashing.

4.13 Tile Replacement

A. Damaged Tile

1. Break out and replace damaged roof tile. Do not disturb underlayment. Repair underlayment if necessary.
2. Apply adhesive per manufacturers instruction for replacement of broken tile.
3. Immediately set replacement tile in position assuring proper contact.

B. Small Valley and Hip Cuts

1. Elevate nose end of tile in course above small cut tile. Apply adhesive per adhesive manufacturer’s instructions.
2. Immediately set tile in course above in position assuring proper contact.

NOTE: For roof slopes above 7”:12’, on hip cuts only, mechanical fastening may be required.

4.14 Clean-Up

A. Remove all broken tile, debris and excess tile from roof.

4.15 Miscellaneous recommendations

A. Instructions shall be given to all parties involved cautioning against traffic of any kind allowed on finished roof. Damage to roof tiles and/or sub-roof may result.

APPENDIX

ANCHOR SHEET FASTENING TABLE INSTRUCTIONS

CLASSIFICATION OF BUILDINGS AND OTHER STRUCTURES FOR IMPORTANT FACTORS

EXPOSURE CATEGORIES

BASIC WIND SPEED MAP

TABLE 1, ALLOWABLE UPLIFT RESISTANCE FOR ANCHOR SHEET ATTACHMENT

TABLES 2A THROUGH 3D REQUIRED DESIGN PRESSURE FOR UNDERLAYMENT AND HIP AND RIDGE TILE

REQUIRED AERODYNAMIC UPLIFT MOMENT TABLES INSTRUCTIONS

TABLES 4A THROUGH 5D REQUIRED AERODYNAMIC UPLIFT MOMENT TABLES

TABLES 6 THROUGH 9 TILE ATTACHMENT RESISTANCE VALUES USING MECHANICAL FASTENERS

TABLE 10 TILE ATTACHMENT RESISTANCE INSTRUCTIONS FOR ADHESIVE-SET, MORTAR SET AND PROPRIETARY MECHANICAL FASTENING SYSTEMS

TABLE 11 HIP AND RIDGE SUPPORT MEMBER ATTACHMENT INSTRUCTIONS

Anchor Sheet Fastening Table Instructions

The mean roof height limitations for attaching an anchor sheet to a wood surface substrate are based on many variables. The nail spacing, type of nail, thickness of the sheathing, type of anchor sheet, and the pitch of the roof are the variables we took into account to determine the mean roof height limitations in Tables 1.

Table 1

Table 1 is to be used when utilizing a two-ply, hot or cold process, underlayment system or for systems where a cap sheet is bonded to an anchor sheet and applying roof tiles with an adhesive-set or mortar-set system. This table indicates the fastening pattern for the field, the underlayment laps, any back nailing requirements of the cap sheet for both smooth or deformed shank nails.

Tables 2A through 2D and 3A through 3D

Tables 2A through 2D are the required underlayment design pressures and required (conservative) hip and ridge design pressures based on Exposure B. Tables 3A through 3D are the required underlayment design pressures and required (conservative) hip and ridge design pressures based on Exposure C. (See the classification of buildings and other structures for importance factors on page 104 and Exposure Categories on page 105.)

Instructions

- Step 1) **Determine the required underlayment design pressure** from Tables 2A through 3D based on the following parameters:
- a) Classification of Buildings and Other Structures for Importance Factors: Determine from the Classification of Buildings and Other Structures for Importance Factors and the Exposure Categories listed on page 104 and 105.
 - b) Pitch of Roof: Acquire from job site.
 - c) Mean Roof Height: Acquire from job site.
 - d) Basic Wind Speed: Determine basic wind speed for your area from Basic Wind Speed Map on page 106 and be sure to check with the local building code, especially for areas where the boundary lines intersect a county.

Example

- a) Exposure Category: B
- b) Building Category: II
- c) Importance Factor: 1.00
- d) Type and Pitch of Roof: Gable - 5:12
- e) Mean Roof Height: 20 feet
- f) Basic Wind Speed: 140 mph

Based on the above mentioned parameters and Table 1, the required underlayment design pressure for the example above = 77.7 psf

Step 2) Determine the appropriate fastening pattern required to meet or exceed the underlayment design pressures as determined in step 1 above. Refer to Table 1, the allowable uplift resistance values are determined by the following parameters:

- a) Determine the thickness of the sheathing (15/32” or 19/32”) from the job site.
- b) Determine the type of nail to be used on the job site (smooth or ring shank).
- c) Find the allowable uplift pressure from Table 1 that meets or exceeds the required design pressure as determined from step 1 above. The anchor sheet must be attached to the substrate according to the required fastening pattern determined above.

Example:

30 / 90 hot mop system

19/32” plywood (5/8”) - Use 19/32” columns

Ring Shank nails - use “Deformed” column under the 19/32” column

Using the example in step 1 above, use a fastening pattern that meets or exceeds 77.7 psf.

The minimum options are as follows:

- 1) Two rows 6” on center in the field 6” at the laps and back nail the cap sheet 12” on center. **This fastening pattern achieves 82.9 psf.**
- or,
- 2) Three rows 10” on center in the field 6” at the laps and back nail the cap sheet 12” on center. **This fastening pattern achieves 78.3 psf.**

Either one of these fastening pattern options is an acceptable anchor sheet fastening pattern.

CLASSIFICATION OF BUILDINGS AND OTHER STRUCTURES FOR IMPORTANCE FACTORS

**TABLE 1604.5
CLASSIFICATION OF BUILDINGS AND OTHER STRUCTURES FOR IMPORTANCE FACTORS**

CATEGORY	NATURE OF OCCUPANCY	WIND FACTOR I_w
I	Buildings and other structures that represent a low hazard to human life in the event of failure including, but not limited to: <ul style="list-style-type: none"> • Agricultural facilities • Certain temporary facilities • Minor storage facilities • Screen enclosures 	0.87 ^a
II	Buildings and other structures except those listed in Categories I, III and IV	1.00
III	Buildings and other structures that represent a substantial hazard to human life in the event of failure including, but not limited to: <ul style="list-style-type: none"> • Buildings and other structures where more than 300 people congregate in one area • Buildings and other structures with elementary school, secondary school or day care facilities with an occupant load greater than 250 • Buildings and other structures with an occupant load greater than 500 for colleges or adult education facilities • Health care facilities with an occupant load of 50 or more resident patients but not having surgery or emergency treatment facilities • Jails and detention facilities • Any other occupancy with an occupant load greater than 5,000 • Power-generating stations, water treatment for potable water, waste water treatment facilities and other public utility facilities not included in Category IV • Buildings and other structures not included in Category IV containing sufficient quantities of toxic or explosive substances to be dangerous to the public if released 	1.15
IV	Buildings and other structures designed as essential facilities including, but not limited to: <ul style="list-style-type: none"> • Hospitals and other health care facilities having surgery or emergency treatment facilities • Fire, rescue and police stations and emergency vehicle garages • Designated earthquake, hurricane or other emergency shelters • Designated emergency preparedness, communication, and operation centers and other facilities required for emergency response • Power-generating stations and other public utility facilities required as emergency backup facilities for Category IV structures • Structures containing highly toxic materials as defined by Section 307 where the quantity of the material exceeds the maximum allowable quantities of Table 307.7(2) • Aviation control towers, air traffic control centers and emergency aircraft hangars • Buildings and other structures having critical national defense functions • Water treatment facilities required to maintain water pressure for fire suppression 	1.15

a. In hurricane-prone regions with $V > 100$ miles per hour, I_w shall be 0.77.

16.6

FLORIDA BUILDING CODE — BUILDING

STRUCTURAL DESIGN

local ordinance using recognized physical landmarks such as major roads, canals, rivers and lake shores, wherever possible.

1609.3.1 Wind speed conversion. When required, the 3-second gust wind velocities of Figure 1609 shall be converted to fastest-mile wind velocities using Table 1609.3.1.

1609.4 Exposure category. For each wind direction considered, an exposure category that adequately reflects the characteristics of ground surface irregularities shall be determined for the site at which the building or structure is to be constructed. For a site located in the transition zone between categories, the category resulting in the largest wind forces shall apply. Account shall be taken of variations in ground surface roughness that arise from natural topography and vegetation as well as from constructed features. For any given wind direction, the exposure in which a specific building or other structure is sited shall be assessed as being one of the following categories. When applying the simplified wind load method of Section 1609.6, a single exposure category shall be used based upon the most restrictive for any given wind direction.

1. **Exposure A.** Large city centers with at least 50 percent of the buildings having a height in excess of 70 feet (21.3 m). Use of this exposure category shall be limited to those areas for which terrain representative of Exposure A prevails in the upwind direction for a distance of at least one-half mile (0.8 km) or 10 times the height of the building or other structure, whichever is greater. Possible channeling effects or increased velocity pressures caused by the building or structure being located in the wake of adjacent buildings shall be taken into account.
2. **Exposure B.** Urban and suburban areas, wooded areas or other terrain with numerous closely spaced obstructions having the size of single-family dwellings or larger. Exposure B shall be assumed unless the site meets the definition of another type of exposure.
3. **Exposure C.** Means, except in the high-velocity hurricane zone, that area which lies within 1,500 feet (46 m) of the coastal construction control line, or within 1,500 feet (46 m) of the mean high tide line, whichever is less. On barrier islands, exposure category C shall be applicable in the coastal building zone set forth in Section 161.55(4), Florida statutes.
4. **Exposure D.** Flat, unobstructed areas exposed to wind flowing over open water (excluding shorelines in hurricane-prone regions) for a distance of at least 1 mile (1.61 km). Shorelines in Exposure D include inland water-

ways, the Great Lakes and coastal areas of California, Oregon, Washington and Alaska. This exposure shall apply only to those buildings and other structures exposed to the wind coming from over the water. Exposure D extends inland from the shoreline a distance of 1,500 feet (460 m) or 10 times the height of the building or structure, whichever is greater.

1609.5 Importance factor. Buildings and other structures shall be assigned a wind load importance factor, I_w , in accordance with Table 1604.5.

1609.6 Simplified provisions for low-rise buildings.

1609.6.1 Scope. Procedures in Section 1609.6 shall be used for determining and applying wind pressures in the design of simple diaphragm buildings with flat, hipped and gable-shaped roofs having a mean roof height not exceeding the least horizontal dimension of the building or 60 feet (18.3 m), whichever is less.

The provisions of Section 1609.6 shall not be used if any of the following conditions exist:

1. Buildings on which exterior glazing is considered to be openings in accordance with Section 1609.1.4.
2. Buildings sited on the upper half of an isolated hill or escarpment meeting all the following conditions:
 - 2.1 The hill or escarpment is 60 feet (18.3 m) or higher if located in exposure B or 30 feet (9.1 m) or higher if located in Exposure C.
 - 2.2 The maximum average slope of the hill exceeds 10 percent.
 - 2.3 The hill or escarpment is unobstructed upwind by other such topographic features for a distance from the high point of 50 times the height of the hill or 1 mile (1.6 km), whichever is less.

1609.6.1.1 Reserved.

1609.6.1.2 Reserved.

1609.6.2 Wind pressures.

1609.6.2.1 Structural members, cladding, fasteners and systems providing for the structural integrity of the building shall be designed for the loads from Table 1609.6A, Table 1609.6B and Table 1609.6C using Figure 1609, multiplied by the appropriate height and exposure coefficient from Table 1609.6D and the importance factor from Table 1604.5.

TABLE 1609.3.1
EQUIVALENT BASIC WIND SPEEDS^{a, b, c}

V_{3S}	85	90	100	105	110	120	125	130	140	145	150	160	170
V_{fm}	70	75	80	85	90	100	105	110	120	125	130	140	150

For SI: 1 mile per hour = 0.44 m/s.
 a. Linear interpolation is permitted.
 b. V_{3S} is the 3-second gust wind speed (mph).
 c. V_{fm} is the fastest mile wind speed (mph).

Basic Wind Speed Map

STRUCTURAL DESIGN

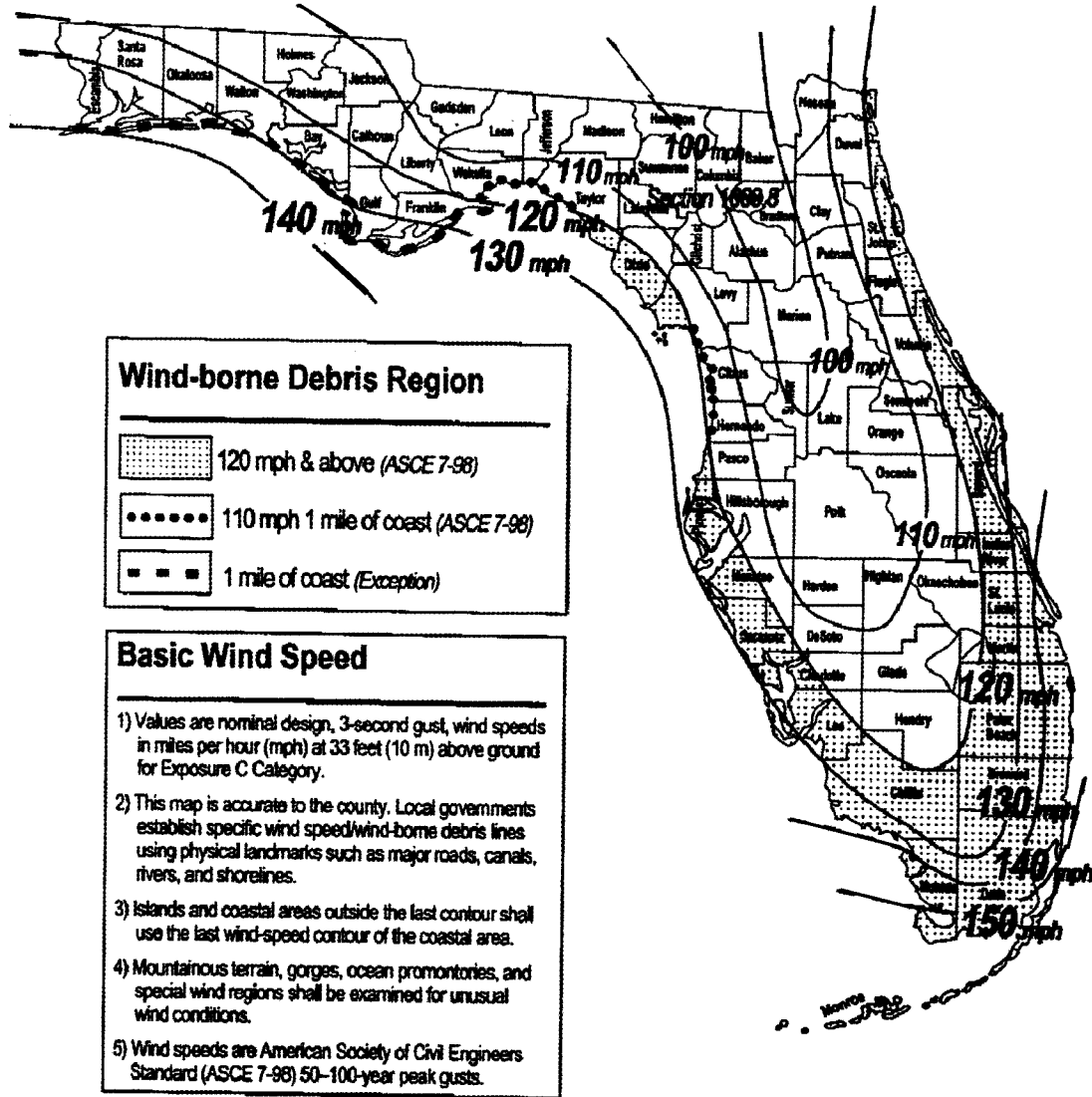

Figure 1609
STATE OF FLORIDA
WIND-BORNE DEBRIS REGION & BASIC WIND SPEED

TABLE 1
Underlayment Table for Systems 3 & 4 only.

ALLOWABLE UPLIFT RESISTANCE FOR ANCHOR SHEET ATTACHMENT
 (For use with a two-ply underlayment system where a cap sheet is bonded to an anchor sheet)

Note ¹: For Mechanically Attached Single Ply Underlayment Systems Contact the Adhesive Manufacturer

Two-Ply Underlayment Fastening Systems - (Two Rows in Field)							
Attachment	Field (inches o/c)	Lap (inches o/c)	Backnail Cap Sheet (inches o/c)	Allowable Uplift Resistance (psf)			
				15/32 inch		19/32 inch	
				Smooth	Deformed ¹	Smooth	Deformed ¹
Two rows staggered in the field, one row at the lap, and one row at the top edge of the cap sheet.	12	6	12	41.6	47.4	52.7	60.0
	11	6	12	43.1	49.1	54.6	62.1
	10	6	12	44.9	51.0	56.8	64.6
	9	6	12	47.0	53.5	59.5	67.7
	8	6	12	49.6	56.5	62.9	71.5
	7	6	12	53.0	60.3	67.2	76.4
	6	6	12	57.6	65.5	72.9	82.9
	5	6	12	63.9	72.7	81.0	92.0
	4	6	12	73.5	83.6	93.0	105.8
3	6	12	89.3	101.6	113.2	128.6	

Two-Ply Underlayment Fastening Systems - (Three Rows in Field)							
Attachment	Field (inches o/c)	Lap (inches o/c)	Backnail Cap Sheet (inches o/c)	Allowable Uplift Resistance (psf)			
				15/32 inch		19/32 inch	
				Smooth	Deformed ¹	Smooth	Deformed ¹
Three rows staggered in the field, one row at the lap, and one row at the top edge of the cap sheet.	12	6	12	49.6	56.5	62.9	71.5
	11	6	12	51.8	58.9	65.6	74.6
	10	6	12	54.4	61.9	68.9	78.3
	9	6	12	57.6	65.5	72.9	82.9
	8	6	12	61.5	70.0	78.0	88.6
	7	6	12	66.6	75.8	84.4	96.0
	6	6	12	73.5	83.6	93.0	105.8
	5	6	12	83.0	94.4	105.1	119.5
	4	6	12	97.3	110.7	123.2	140.1
3	6	12	121.1	137.8	153.4	174.4	

Two-Ply Underlayment Fastening Systems - (Four Rows in Field)							
Attachment	Field (inches o/c)	Lap (inches o/c)	Backnail Cap Sheet (inches o/c)	Allowable Uplift Resistance (psf)			
				15/32 inch		19/32 inch	
				Smooth	Deformed ¹	Smooth	Deformed ¹
Four rows staggered in the field, one row at the lap, and one row at the top edge of the cap sheet.	12	6	12	58.6	66.6	74.2	84.3
	11	6	12	61.4	69.9	77.8	88.5
	10	6	12	64.9	73.9	82.2	93.5
	9	6	12	69.2	78.7	87.6	99.6
	8	6	12	74.4	84.7	94.3	107.2
	7	6	12	81.3	92.4	102.9	117.0
	6	6	12	90.3	102.8	114.4	130.1
	5	6	12	103.0	117.2	130.5	148.4
	4	6	12	122.1	138.9	154.6	175.8
3	6	12	153.9	175.1	194.9	221.6	

Note¹: Deformed shank is inclusive of either a ring or screw shank nail.

Table 2A
Category II Buildings
Underlayment Table for Systems 3 & 4 Only
and
Hip and Ridge Design Pressures

Height (ft) above ground level, z		Required Design Pressures, p (psf) Exposure B												
		Basic Wind Speed, V; (mph)												
		90	100	105	110	120	125	130	140	145	150			
		Standard or Special Occupancy Structures having an Importance Factor of 1.00												
0 - 30		32.1	39.6	43.7	48.0	57.1	61.9	67.0	77.7	83.3	89.2			
40		34.9	43.0	47.4	52.1	62.0	67.2	72.7	84.3	90.5	96.8			
50		37.2	45.9	50.6	55.5	66.0	71.7	77.5	89.9	96.4	103.2			
60		39.1	48.3	53.3	58.5	69.6	75.5	81.7	94.7	101.6	108.7			
		Essential or Hazardous Facilities having an Importance Factor of 1.15												
0 - 30		36.9	45.6	50.3	55.2	65.6	71.2	77.0	89.3	95.8	102.6			
40		40.1	49.5	54.6	59.9	71.3	77.3	83.6	97.0	104.0	111.3			
50		42.7	52.7	58.2	63.8	76.0	82.4	89.1	103.4	110.9	118.7			
60		45.0	55.6	61.3	67.2	80.0	86.8	93.9	108.9	116.8	125.0			

Note¹: For Building Category Definition See Page 104.

Note²: For Exposure Categories See Page 105.

Note³: Table conforms to ASCE 7-02.

Note⁴: For mean roof heights over 60 feet, engineering calculations must be submitted for permitting.

Note⁵: The above design pressures are conservative for any hip/ridge tile with an exposed area of 144 sq. inches (1 sq. ft.) or less. Determine the actual square foot area of the tile being used using the following formula:
 (A) ft² = (W) (in inches) x (L) (in inches) / 144 (sq. in.)

(A) = Actual hip/ridge area (ft²)

(W) = The average exposed width of the hip/ridge tile (in inches).

(L) = The actual length of the hip/ridge tile (in inches) minus the head lap being used (typically 2”).

To determine the required hip/ridge design pressure for the tile being used, multiply (A) (sq. ft.) times the appropriate design pressures listed in Tables 2A through 3D.

Table 2B
Category II Buildings
Underlayment Table for Systems 3 & 4 Only
and
Hip and Ridge Design Pressures

Required Design Pressures, p (psf)												
Exposure B												
Hip Roofs (For Slopes 2:12 < ? < = 5½:12)												
Basic Wind Speed, V; (mph)												
Height (ft) above ground level, z	90	100	105	110	120	125	130	140	145	150		
Standard or Special Occupancy Structures having an Importance Factor of 1.00												
0 - 30	21.0	25.9	28.6	31.4	37.3	40.5	43.8	50.8	54.5	58.3		
40	22.8	28.1	31.0	34.0	40.5	44.0	47.6	55.1	59.2	63.3		
50	24.3	30.0	33.1	36.3	43.2	46.9	50.7	58.8	63.1	67.5		
60	25.6	31.6	34.8	38.2	45.5	49.4	53.4	61.9	66.4	71.1		
Essential or Hazardous Facilities having an Importance Factor of 1.15												
0 - 30	24.1	29.8	32.9	36.1	42.9	46.6	50.4	58.4	62.7	67.1		
40	26.2	32.4	35.7	39.2	46.6	50.6	54.7	63.4	68.0	72.8		
50	27.9	34.5	38.0	41.7	49.7	53.9	58.3	67.6	72.5	77.6		
60	29.4	36.3	40.1	44.0	52.3	56.8	61.4	71.2	76.4	81.7		

Note¹: For Building Category Definition See Page 104.

Note²: For Exposure Categories See Page 105.

Note³: Table conforms to ASCE 7-02.

Note⁴: For mean roof heights over 60 feet, engineering calculations must be submitted for permitting.

Note⁵: The above design pressures are conservative for any hip/ridge tile with an exposed area of 144 sq. inches (1 sq. ft.) or less. Determine the actual square foot area of the tile being used using the following formula:
 (A) ft² = (W) (in inches) x (L) (in inches) / 144 (sq. in.)

(A) = Actual hip/ridge area (ft²)

(W) = The average exposed width of the hip/ridge tile (in inches).

(L) = The actual length of the hip/ridge tile (in inches) minus the head lap being used (typically 2”).

To determine the required hip/ridge design pressure for the tile being used, multiply (A) (sq. ft.) times the appropriate design pressures listed in Tables 2A through 3D.

Table 2C
Category II Buildings
Underlayment Table for Systems 3 & 4 Only
and
Hip and Ridge Design Pressures

Required Design Pressures, p (psf)											
Exposure B											
Gable Roofs (For Slopes 6:12 < ? < = 12:12)											
Height (ft) above ground level, z	Basic Wind Speed, V; (mph)										
	90	100	105	110	120	125	130	140	145	150	
Standard or Special Occupancy Structures having an Importance Factor of 1.00											
0 - 30	14.8	18.3	20.2	22.1	26.3	28.6	30.9	35.9	38.5	41.2	
40	16.1	19.9	21.9	24.0	28.6	31.0	33.6	38.9	41.8	44.7	
50	17.1	21.2	23.3	25.6	30.5	33.1	35.8	41.5	44.5	47.6	
60	18.1	22.3	24.6	27.0	32.1	34.8	37.7	43.7	46.9	50.2	
Essential or Hazardous Facilities having an Importance Factor of 1.15											
0 - 30	17.0	21.0	23.2	25.5	30.3	32.9	35.6	41.2	44.2	47.3	
40	18.5	22.8	25.2	27.6	32.9	35.7	38.6	44.8	48.0	51.4	
50	19.7	24.3	26.8	29.5	35.1	38.0	41.1	47.7	51.2	54.8	
60	20.8	25.6	28.3	31.0	36.9	40.1	43.3	50.3	53.9	57.7	

Note¹: For Building Category Definition See Page 104.

Note²: For Exposure Categories See Page 105.

Note³: Table conforms to ASCE 7-02.

Note⁴: For mean roof heights over 60 feet, engineering calculations must be submitted for permitting.

Note⁵: The above design pressures are conservative for any hip/ridge tile with an exposed area of 144 sq. inches (1 sq. ft.) or less. Determine the actual square foot area of the tile being used using the following formula:
 (A) ft² = (W) (in inches) x (L) (in inches) / 144 (sq. in.)

(A) = Actual hip/ridge area (ft²)

(W) = The average exposed width of the hip/ridge tile (in inches).

(L) = The actual length of the hip/ridge tile (in inches) minus the head lap being used (typically 2”).

To determine the required hip/ridge design pressure for the tile being used, multiply (A) (sq. ft.) times the appropriate design pressures listed in Tables 2A through 3D.

Table 2D
Category II Buildings
Underlayment Table for Systems 3 & 4 Only
and
Hip and Ridge Design Pressures

Required Design Pressures, p (psf)		Exposure B									
		Monoslope Roofs (For Slopes 2½:12 < ? < = 6¾:12)									
Height (ft) above ground level, z	Basic Wind Speed, V; (mph)										
	90	100	105	110	120	125	130	140	145	150	
Standard or Special Occupancy Structures having an Importance Factor of 1.00											
0 - 30	35.8	44.2	48.7	53.5	63.7	69.1	74.7	86.7	93.0	99.5	
40	38.9	48.0	52.9	58.1	69.1	75.0	81.1	94.1	100.9	108.0	
50	41.4	51.2	56.4	61.9	73.7	79.9	86.5	100.3	107.6	115.1	
60	43.7	53.9	59.4	65.2	77.6	84.2	91.1	105.6	113.3	121.3	
Essential or Hazardous Facilities having an Importance Factor of 1.15											
0 - 30	41.2	50.8	56.1	61.5	73.2	79.4	85.9	99.6	106.9	114.4	
40	44.7	55.2	60.9	66.8	79.5	86.2	93.3	108.2	116.1	124.2	
50	47.7	58.8	64.9	71.2	84.7	91.9	99.4	115.3	123.7	132.4	
60	50.2	62.0	68.3	75.0	89.2	96.8	104.7	121.5	130.3	139.4	

Note¹: For Building Category Definition See Page 104.

Note²: For Exposure Categories See Page 105.

Note³: Table conforms to ASCE 7-02.

Note⁴: For mean roof heights over 60 feet, engineering calculations must be submitted for permitting.

Note⁵: The above design pressures are conservative for any hip/ridge tile with an exposed area of 144 sq. inches (1 sq. ft.) or less. Determine the actual square foot area of the tile being used using the following formula:
 (A) ft² = (W) (in inches) x (L) (in inches) / 144 (sq. in.)

(A) = Actual hip/ridge area (ft²)

(W) = The average exposed width of the hip/ridge tile (in inches).

(L) = The actual length of the hip/ridge tile (in inches) minus the head lap being used (typically 2”).

To determine the required hip/ridge design pressure for the tile being used, multiply (A) (sq. ft.) times the appropriate design pressures listed in Tables 2A through 3D.

Table 3A
Category II Buildings
Underlayment Table for Systems 3 & 4 Only
and
Hip and Ridge Design Pressures

Height (ft) above ground level, z		Required Design Pressures, p (psf) Exposure C																				
		90	100	105	110	120	125	130	140	145	150											
		Standard or Special Occupancy Structures having an Importance Factor of 1.00																				
0 - 15		38.9	48.0	52.9	58.1	69.2	75.0	81.2	94.1	101.0	108.1											
20		41.3	51.0	56.3	61.7	73.5	79.7	86.2	100.0	107.3	114.8											
25		43.3	53.5	59.0	64.7	77.0	83.6	90.4	104.8	112.4	120.3											
30		45.0	55.6	61.3	67.2	80.0	86.8	93.9	108.9	116.8	125.0											
40		47.8	59.0	65.1	71.4	85.0	92.3	99.8	115.7	124.1	132.8											
50		50.1	61.9	68.2	74.9	89.1	96.7	104.6	121.3	130.1	139.2											
60		52.1	64.3	70.9	77.8	92.6	100.5	108.7	126.0	135.2	144.7											
		Essential or Hazardous Facilities having an Importance Factor of 1.15																				
0 - 15		44.7	55.2	60.9	66.8	79.5	86.3	93.3	108.3	116.1	124.3											
20		47.5	58.7	64.7	71.0	84.5	91.7	99.2	115.0	123.4	132.0											
25		49.8	61.5	67.8	74.4	88.6	96.1	103.9	120.5	129.3	138.4											
30		51.8	63.9	70.5	77.3	92.0	99.9	108.0	125.3	134.4	143.8											
40		55.0	67.9	74.9	82.2	97.8	106.1	114.7	133.1	142.8	152.8											
50		57.6	71.2	78.5	86.1	102.5	111.2	120.3	139.5	149.6	160.1											
60		59.9	73.9	81.5	89.5	106.5	115.5	125.0	144.9	155.5	166.4											

Note¹: For Building Category Definition See Page 104.

Note²: For Exposure Categories See Page 105.

Note³: Table conforms to ASCE 7-02.

Note⁴: For mean roof heights over 60 feet, engineering calculations must be submitted for permitting.

Note⁵: The above design pressures are conservative for any hip/ridge tile with an exposed area of 144 sq. inches (1 sq. ft.) or less. Determine the actual square foot area of the tile being used using the following formula:

$$(A) ft^2 = (W) \text{ (in inches)} \times (L) \text{ (in inches)} / 144 \text{ (sq. in.)}$$

(A) = Actual hip/ridge area (ft²)

(W) = The average exposed width of the hip/ridge tile (in inches).

(L) = The actual length of the hip/ridge tile (in inches) minus the head lap being used (typically 2").

To determine the required hip/ridge design pressure for the tile being used, multiply (A) (sq. ft.) times the appropriate design pressures listed in Tables 2A through 3D.

Table 3B
Category II Buildings
Underlayment Table for Systems 3 & 4 Only
and
Hip and Ridge Design Pressures

Required Design Pressures, p (psf) Exposure C		Hip Roofs (For Slopes 2:12 < ? < = 5½:12)									
		Basic Wind Speed, V; (mph)									
Height (ft) above ground level, z	90	100	105	110	120	125	130	140	145	150	
		Standard or Special Occupancy Structures having an Importance Factor of 1.00									
0 - 15	25.4	31.4	34.6	38.0	45.2	49.1	53.1	61.5	66.0	70.7	
20	27.0	33.4	36.8	40.4	48.0	52.1	56.4	65.4	70.1	75.1	
25	28.3	35.0	38.6	42.3	50.4	54.6	59.1	68.5	73.5	78.7	
30	29.4	36.3	40.1	44.0	52.3	56.8	61.4	71.2	76.4	81.8	
40	31.3	38.6	42.6	46.7	55.6	60.3	65.2	75.7	81.2	86.9	
50	32.8	40.5	44.6	49.0	58.3	63.2	68.4	79.3	85.1	91.0	
60	34.1	42.0	46.4	50.9	60.5	65.7	71.1	82.4	88.4	94.6	
	Essential or Hazardous Facilities having an Importance Factor of 1.15										
0 - 15	29.3	36.1	39.8	43.7	52.0	56.4	61.0	70.8	75.9	81.3	
20	31.1	38.4	42.3	46.4	55.2	59.9	64.8	75.2	80.7	86.3	
25	32.6	40.2	44.3	48.7	57.9	62.8	68.0	78.8	84.5	90.5	
30	33.8	41.8	46.1	50.6	60.2	65.3	70.6	81.9	87.9	94.0	
40	36.0	44.4	48.9	53.7	63.9	69.4	75.0	87.0	93.3	99.9	
50	37.7	46.5	51.3	56.3	67.0	72.7	78.6	91.2	97.8	104.7	
60	39.2	48.4	53.3	58.5	69.6	75.5	81.7	94.8	101.7	108.8	

Note¹: For Building Category Definition See Page 104.

Note²: For Exposure Categories See Page 105.

Note³: Table conforms to ASCE 7-02.

Note⁴: For mean roof heights over 60 feet, engineering calculations must be submitted for permitting.

Note⁵: The above design pressures are conservative for any hip/ridge tile with an exposed area of 144 sq. inches (1 sq. ft.) or less. Determine the actual square foot area of the tile being used using the following formula:

$$(A) \text{ ft}^2 = (W) \text{ (in inches)} \times (L) \text{ (in inches)} / 144 \text{ (sq. in.)}$$

(A) = Actual hip/ridge area (ft²)

(W) = The average exposed width of the hip/ridge tile (in inches).

(L) = The actual length of the hip/ridge tile (in inches) minus the head lap being used (typically 2").

To determine the required hip/ridge design pressure for the tile being used, multiply (A) (sq. ft.) times the appropriate design pressures listed in Tables 2A through 3D.

Table 3C
Category II Buildings
Underlayment Table for Systems 3 & 4 Only
and
Hip and Ridge Design Pressures

Required Design Pressures, p (psf) Exposure C		Basic Wind Speed, V; (mph)												
		90	100	105	110	120	125	130	140	145	150			
Gable Roofs (For Slopes 6:12 < ? < = 12:12)		Standard or Special Occupancy Structures having an Importance Factor of 1.00												
Height (ft) above ground level, z	0 - 15	18.0	22.2	24.4	26.8	31.9	34.6	37.5	43.4	46.6	49.9			
	20	19.1	23.6	26.0	28.5	33.9	36.8	39.8	46.2	49.5	53.0			
	25	20.0	24.7	27.2	29.9	35.5	36.6	41.7	48.4	51.9	55.5			
	30	20.8	25.6	28.3	31.0	36.9	40.1	43.3	50.3	53.9	57.7			
	40	22.1	27.2	30.0	33.0	39.2	42.6	46.1	53.4	57.3	61.3			
	50	23.1	28.6	31.5	34.6	41.1	44.6	48.3	56.0	60.0	64.3			
	60	24.0	29.7	32.7	35.9	42.7	46.4	50.2	58.2	62.4	66.8			
		Essential or Hazardous Facilities having an Importance Factor of 1.15												
	0 - 15	20.6	25.5	28.1	30.8	36.7	39.8	43.1	50.0	53.6	57.4			
	20	21.9	27.1	29.9	32.8	39.0	42.3	45.8	53.1	56.9	60.9			
	25	23.0	28.4	31.1	34.3	40.9	44.4	48.0	55.6	59.7	63.9			
	30	23.9	29.5	32.5	35.7	42.5	46.1	49.8	57.8	62.0	66.4			
	40	25.4	31.3	34.5	37.9	45.1	49.0	53.0	61.4	65.9	70.5			
	50	26.6	32.8	36.2	39.7	47.3	51.3	55.5	64.4	69.1	73.9			
	60	27.6	34.1	37.6	41.3	49.1	53.3	57.7	66.9	71.8	76.8			

Note¹: For Building Category Definition See Page 104.

Note²: For Exposure Categories See Page 105.

Note³: Table conforms to ASCE 7-02.

Note⁴: For mean roof heights over 60 feet, engineering calculations must be submitted for permitting.

Note⁵: The above design pressures are conservative for any hip/ridge tile with an exposed area of 144 sq. inches (1 sq. ft.) or less. Determine the actual square foot area of the tile being used using the following formula:
 (A) $ft^2 = (W) \times (L)$ (in inches) / 144 (sq. in.)

(A) = Actual hip/ridge area (ft²)

(W) = The average exposed width of the hip/ridge tile (in inches).

(L) = The actual length of the hip/ridge tile (in inches) minus the head lap being used (typically 2").

To determine the required hip/ridge design pressure for the tile being used, multiply (A) (sq. ft.) times the appropriate design pressures listed in Tables 2A through 3D.

Table 3D
Category II Buildings
Underlayment Table for Systems 3 & 4 Only
and
Hip and Ridge Design Pressures

Height (ft) above ground level, z		Required Design Pressures, p (psf)												
		Exposure C												
		Monoslope Roofs (For Slopes $2\frac{1}{2}:12 < ? < 6\frac{3}{4}:12$)												
		Basic Wind Speed, V; (mph)												
		90	100	105	110	120	125	130	140	145	150			
		Standard or Special Occupancy Structures having an Importance Factor of 1.00												
0 - 15		43.4	53.6	59.1	64.8	77.1	83.7	90.5	105.0	112.6	120.5			
20		46.1	56.9	62.7	68.9	82.0	88.9	96.2	111.5	119.7	128.1			
25		48.3	59.6	65.8	72.2	85.9	93.2	100.8	116.9	125.4	134.2			
30		50.2	62.0	68.3	75.0	89.3	96.9	104.8	121.5	130.3	139.5			
40		53.3	65.9	72.6	79.7	94.8	102.9	111.3	129.1	138.5	148.2			
50		55.9	69.0	76.1	83.5	99.4	107.8	116.6	135.3	145.1	155.3			
60		58.1	71.7	79.1	86.8	103.3	112.1	121.2	140.6	150.8	161.4			
		Essential or Hazardous Facilities having an Importance Factor of 1.15												
0 - 15		49.9	61.6	67.9	74.5	88.7	96.3	104.1	120.7	129.5	138.6			
20		53.0	65.4	72.2	79.2	94.2	102.3	110.6	128.3	137.6	147.3			
25		55.6	68.6	75.6	83.0	98.8	107.2	115.9	134.5	144.2	154.3			
30		57.7	71.3	78.6	86.3	102.6	111.4	120.5	139.7	149.9	160.4			
40		61.3	75.7	83.5	91.6	109.1	118.3	128.0	148.4	159.2	170.4			
50		64.3	79.4	87.5	96.0	114.3	124.0	134.1	155.6	166.9	178.6			
60		66.8	82.5	90.9	99.8	118.8	128.9	139.4	161.7	173.4	185.6			

Note¹: For Building Category Definition See Page 104.

Note²: For Exposure Categories See Page 105.

Note³: Table conforms to ASCE 7-02.

Note⁴: For mean roof heights over 60 feet, engineering calculations must be submitted for permitting.

Note⁵: The above design pressures are conservative for any hip/ridge tile with an exposed area of 144 sq. inches (1 sq. ft.) or less. Determine the actual square foot area of the tile being used using the following formula:

$$(A) ft^2 = (W) \text{ (in inches)} \times (L) \text{ (in inches)} / 144 \text{ (sq. in.)}$$

(A) = Actual hip/ridge area (ft²)

(W) = The average exposed width of the hip/ridge tile (in inches).

(L) = The actual length of the hip/ridge tile (in inches) minus the head lap being used (typically 2").

To determine the required hip/ridge design pressure for the tile being used, multiply (A) (sq. ft.) times the appropriate design pressures listed in Tables 2A through 3D.

Required Aerodynamic Uplift Moment Tables Instructions

The required aerodynamic uplift moment values for determining the attachment of clay and concrete tiles are based on many variables. The building category, importance factor, building exposure, basic wind speed, slope of roof, and a generic tile dimension (tile factor) of 1.407 are the variables we took into account to determine the required uplift moment in Tables 4A through 5D.

Tables 4A through 5D

Tables 4A through 4D are to be used for non-coastal construction.

Tables 5A and 5D are to be used for coastal construction.

1. Determine the building category and importance factor from page 104, and the exposure category from page 105.
2. Determine the mean roof height and slope of the roof.
3. Select the appropriate table based on then information gathered from numbers 1 and 2 above.
4. Follow across the basic wind speed row to the appropriate basic wind speed for the project. Then follow down the column to the appropriate mean roof height to determine the required aerodynamic uplift moment.

Tables 6, through 10

1. Select Tables 6, 8 or 9 based on the thickness of the decking and if tiles will be attached directly to the deck, or use Table 7 if the tiles will be attached to battens. Refer to Table 10 for Adhesive-set or Mortar-set systems.
2. Select an attachment method where the uplift capacity from Tables 6 through 9 is equal to or greater than the appropriate aerodynamic values listed in Tables 4A through 5D. Refer to the adhesive, mortar or roof tile manufacturer's product approval or evaluation report for the resistance values for these attachment systems.

Table 11

Hip and ridge support member attachment recommendations.

For Hip and Ridge Attachment Requirements

Note¹: To determine the required design pressures for the hip/ridge tiles, use the appropriate table from Tables 2A through 3D based on the job site parameters. The design pressures are conservative for any hip/ridge tile with an exposed area of 144 sq. inches (1 sq. ft.) or less. Determine the actual square foot area of the tile being used using the following formula:

(A) ft² = (W) (in inches) x (L) (in inches) / 144 (sq. in.)

(A) = Actual hip/ridge area (ft²)

(W) = The average exposed width of the hip/ridge tile (in inches).

(L) = The actual length of the hip/ridge tile (in inches) minus the head lap being used (typically 2").

Note²: Resistance values for the hip and ridge tile are proprietary, and are dependent on the system used for attachment of the hip and ridge tile. Refer to Table 10 and the appropriate manufacturer's product approval or evaluation report to determine the proper attachment method to meet or exceed the hip/ridge design pressures.

Table 4A
Category II Buildings
Exposure B - Non-Coastal

Required Aerodynamic Uplift Moment, M_a (ft-lbf)											
Exposure B											
Gable Roofs (For Slopes 2:12 < θ < = 6:12)											
Hip Roofs (For Slopes 5½ :12 < θ < = 6:12)											
Basic Wind Speed, V_i (mph)											
Height (ft) above ground level, z	90	100	105	110	120	125	130	140	145	150	
Standard or Special Occupancy Structures having an Importance Factor of 1.00											
0 - 30	12.5	15.4	17.0	18.7	22.2	24.1	26.1	30.3	32.5	34.7	
40	13.6	16.8	18.5	20.3	24.1	26.2	28.3	32.9	35.3	37.7	
50	14.5	17.9	19.7	21.6	25.7	27.9	30.2	35.0	37.6	40.2	
60	15.2	18.8	20.8	22.8	27.1	29.4	31.8	36.9	39.6	42.4	
Essential or Hazardous Facilities having an Importance Factor of 1.15											
0 - 30	14.4	17.8	19.6	21.5	25.6	27.7	30.0	34.8	37.3	40.0	
40	15.6	19.3	21.3	23.3	27.8	30.1	32.6	37.8	40.5	43.4	
50	16.6	20.6	22.7	24.9	29.6	32.1	34.7	40.3	43.2	46.2	
60	17.5	21.6	23.9	26.2	31.2	33.8	36.6	42.4	45.5	48.7	

Note¹: For Building Category Definition See Page 104.

Note²: For Exposure Categories See Page 105.

Note³: Table conforms to ASCE 7-02.

Note⁴: For mean roof heights over 60 feet, engineering calculations must be submitted for permitting.

Table 4B
Category II Buildings
Exposure B - Non-Coastal

Required Aerodynamic Uplift Moment, M_a (ft-lbf)											
Exposure B											
Hip Roofs (For Slopes $2:12 < \theta \leq 5\frac{1}{2}:12$)											
Basic Wind Speed, V ; (mph)											
Height (ft) above ground level, z	90	100	105	110	120	125	130	140	145	150	
Standard or Special Occupancy Structures having an Importance Factor of 1.00											
0 - 30	9.4	11.6	12.8	14.0	16.7	18.1	19.6	22.7	24.4	26.1	
40	10.2	12.6	13.9	15.2	18.1	19.6	21.3	24.6	26.4	28.3	
50	10.9	13.4	14.8	16.2	19.3	20.9	22.6	26.3	28.2	30.2	
60	11.4	14.1	15.6	17.1	20.3	22.1	23.9	27.7	29.7	31.8	
Essential or Hazardous Facilities having an Importance Factor of 1.15											
0 - 30	10.8	13.3	14.7	16.1	19.2	20.8	22.5	26.1	28.0	30.0	
40	11.7	14.5	15.9	17.5	20.8	22.6	24.4	28.3	30.4	32.5	
50	12.5	15.4	17.0	18.6	22.2	24.1	26.0	30.2	32.4	34.7	
60	13.2	16.2	17.9	19.6	23.4	25.4	27.4	31.8	34.1	36.5	

Note¹: For Building Category Definition See Page 104.

Note²: For Exposure Categories See Page 105.

Note³: Table conforms to ASCE 7-02.

Note⁴: For mean roof heights over 60 feet, engineering calculations must be submitted for permitting.

Table 4C
Category II Buildings
Exposure B - Non-Coastal

Required Aerodynamic Uplift Moment, M_a (ft-lbf)											
Exposure B											
Gable Roofs (For Slopes $6:12 < \theta \leq 12:12$)											
Basic Wind Speed, V ; (mph)											
Height (ft) above ground level, z	90	100	105	110	120	125	130	140	145	150	
Standard or Special Occupancy Structures having an Importance Factor of 1.00											
0 - 30	7.6	9.4	10.4	11.4	13.6	14.7	15.9	18.5	19.8	21.2	
40	8.3	10.2	11.3	12.4	14.8	16.0	17.3	20.1	21.5	23.1	
50	8.8	10.9	12.0	13.2	15.7	17.1	18.5	21.4	23.0	24.6	
60	9.3	11.5	12.7	13.9	16.6	18.0	19.4	22.5	24.2	25.9	
Essential or Hazardous Facilities having an Importance Factor of 1.15											
0 - 30	8.8	10.9	12.0	13.1	15.6	17.0	18.3	21.3	22.8	24.4	
40	9.5	11.8	13.0	14.3	17.0	18.4	19.9	23.1	24.8	26.5	
50	10.2	12.6	13.8	15.2	18.1	19.6	21.2	24.6	26.4	28.3	
60	10.7	13.2	14.6	16.0	19.1	20.7	22.4	25.9	27.8	29.8	

Note¹: For Building Category Definition See Page 104.

Note²: For Exposure Categories See Page 105.

Note³: Table conforms to ASCE 7-02.

Note⁴: For mean roof heights over 60 feet, engineering calculations must be submitted for permitting.

Table 4D
Category II Buildings
Exposure B - Non-Coastal

Required Aerodynamic Uplift Moment, M_a (ft-lbf)												
Exposure B												
Monoslope Roofs (For Slopes $2\frac{1}{2}:12 < \theta < = 6\frac{3}{4}:12$)												
Basic Wind Speed, V ; (mph)												
Height (ft) above ground level, z	90	100	105	110	120	125	130	140	145	150		
Standard or Special Occupancy Structures having an Importance Factor of 1.00												
0 - 30	13.6	16.7	18.4	20.2	24.1	26.1	28.3	32.8	35.2	37.6		
40	14.7	18.2	20.0	22.0	26.2	28.4	30.7	35.6	38.2	40.9		
50	15.7	19.4	21.3	23.4	27.9	30.2	32.7	37.9	40.7	43.6		
60	16.5	20.4	22.5	24.7	29.4	31.9	34.5	40.0	42.9	45.9		
Essential or Hazardous Facilities having an Importance Factor of 1.15												
0 - 30	15.6	19.2	21.2	23.3	27.7	30.1	32.5	37.7	40.5	43.3		
40	16.9	20.9	23.0	25.3	30.1	32.6	35.3	40.9	43.9	47.0		
50	18.0	22.3	24.5	26.9	32.1	34.8	37.6	43.6	46.8	50.1		
60	19.0	23.5	25.9	28.4	33.8	36.6	39.6	46.0	49.3	52.8		

Note¹: For Building Category Definition See Page 104.

Note²: For Exposure Categories See Page 105.

Note³: Table conforms to ASCE 7-02.

Note⁴: For mean roof heights over 60 feet, engineering calculations must be submitted for permitting.

Table 5A
Category II Buildings
Exposure C - Coastal

Required Aerodynamic Uplift Moment, M_a (ft-lbf) Exposure C												
Gable Roofs (For Slopes 2:12 < θ <= 6:12) Hip Roofs (For Slopes 5½ :12 < θ <= 6:12)												
Height (ft) above ground level, z	Basic Wind Speed, V; (mph)											
	90	100	105	110	120	125	130	140	145	150		
Standard or Special Occupancy Structures having an Importance Factor of 1.00												
0 - 15	15.2	18.7	20.6	22.6	26.9	29.2	31.6	36.7	39.3	42.1		
20	16.1	19.9	21.9	24.1	28.6	31.1	33.6	39.0	41.8	44.7		
25	16.9	20.8	23.0	25.2	30.0	32.6	35.2	40.8	43.8	46.9		
30	17.5	21.7	23.9	26.2	31.2	33.8	36.6	42.4	45.5	48.7		
40	18.6	23.0	25.4	27.8	33.1	35.9	38.9	45.1	48.4	51.8		
50	19.5	24.1	26.6	29.2	34.7	37.7	40.7	47.3	50.7	54.2		
60	20.3	25.1	27.6	30.3	36.1	39.1	42.3	49.1	52.7	56.4		
Essential or Hazardous Facilities having an Importance Factor of 1.15												
0 - 15	17.4	21.5	23.7	26.0	31.0	33.6	36.4	42.2	45.2	48.4		
20	18.5	22.9	25.2	27.7	32.9	35.7	38.6	44.8	48.1	51.4		
25	19.4	24.0	26.4	29.0	34.5	37.4	40.5	47.0	50.4	53.9		
30	20.2	24.9	27.5	30.1	35.9	38.9	42.1	48.8	52.4	56.0		
40	21.4	26.5	29.2	32.0	38.1	41.3	44.7	51.8	55.6	59.5		
50	22.5	27.7	30.6	33.5	39.9	43.3	46.9	54.3	58.3	62.4		
60	23.3	28.8	31.8	34.9	41.5	45.0	48.7	56.5	60.6	64.8		

Note¹: For Building Category Definition See Page 104.

Note²: For Exposure Categories See Page 105.

Note³: Table conforms to ASCE 7-02.

Note⁴: For mean roof heights over 60 feet, engineering calculations must be submitted for permitting.

Table 5B
Category II Buildings
Exposure C - Coastal

Required Aerodynamic Uplift Moment, M_a (ft-lbf) Exposure C												
Hip Roofs (For Slopes $2:12 < \theta < = 5\frac{1}{2}:12$)												
Height (ft) above ground level, z	Basic Wind Speed, V; (mph)											
	90	100	105	110	120	125	130	140	145	150		
Standard or Special Occupancy Structures having an Importance Factor of 1.00												
0 - 15	11.4	14.0	15.5	17.0	20.2	21.9	23.7	27.5	29.5	31.6		
20	12.1	14.9	16.4	18.0	21.5	23.3	25.2	29.2	31.3	33.5		
25	12.7	15.6	17.2	18.9	22.5	24.4	26.4	30.6	32.9	35.2		
30	13.2	16.2	17.9	19.6	23.4	25.4	27.4	31.8	34.1	36.5		
40	14.0	17.3	19.0	20.9	24.8	27.0	29.2	33.8	36.3	38.8		
50	14.6	18.1	19.9	21.9	26.0	28.3	30.6	35.4	38.0	40.7		
60	15.2	18.8	20.7	22.7	27.1	29.4	31.8	36.8	39.5	42.3		
Essential or Hazardous Facilities having an Importance Factor of 1.15												
0 - 15	13.1	16.1	17.8	19.5	23.2	25.2	27.3	31.6	33.9	36.3		
20	13.9	17.1	18.9	20.7	24.7	26.8	29.0	33.6	36.1	38.6		
25	14.6	18.0	19.8	21.7	25.9	28.1	30.4	35.2	37.8	40.4		
30	15.1	18.7	20.6	22.6	26.9	29.2	31.6	36.6	39.3	42.0		
40	16.1	19.8	21.9	24.0	28.6	31.0	33.5	38.9	41.7	44.6		
50	16.8	20.8	22.9	25.2	29.9	32.5	35.1	40.8	43.7	46.8		
60	17.5	21.6	23.8	26.1	31.1	33.8	36.5	42.4	45.4	48.6		

Note¹: For Building Category Definition See Page 104.

Note²: For Exposure Categories See Page 105.

Note³: Table conforms to ASCE 7-02.

Note⁴: For mean roof heights over 60 feet, engineering calculations must be submitted for permitting.

Table 5C
Category II Buildings
Exposure C - Coastal

Required Aerodynamic Uplift Moment, M_a (ft-lbf)												
Exposure C												
Gable Roofs (For Slopes 6:12 < θ <= 12:12)												
Height (ft) above ground level, z	Basic Wind Speed, V; (mph)											
	90	100	105	110	120	125	130	140	145	150		
Standard or Special Occupancy Structures having an Importance Factor of 1.00												
0 - 15	9.3	11.4	12.6	13.8	16.5	17.9	19.3	22.4	24.0	25.7		
20	9.8	12.1	13.4	14.7	17.5	19.0	20.5	23.8	25.5	27.3		
25	10.3	12.7	14.0	15.4	18.3	19.9	21.5	25.0	26.8	28.6		
30	10.7	13.2	14.6	16.0	19.1	20.7	22.4	25.9	27.8	29.8		
40	11.4	14.1	15.5	17.0	20.2	22.0	23.8	27.6	29.6	31.6		
50	11.9	14.7	16.2	17.8	21.2	23.0	24.9	28.9	31.0	33.2		
60	12.4	15.3	16.9	18.5	22.0	23.9	25.9	30.0	32.2	34.4		
Essential or Hazardous Facilities having an Importance Factor of 1.15												
0 - 15	10.7	13.2	14.5	15.9	18.9	20.5	22.2	25.8	27.6	29.6		
20	11.3	14.0	15.4	16.9	20.1	21.8	23.6	27.4	29.4	31.4		
25	11.9	14.6	16.1	17.7	21.1	22.9	24.7	28.7	30.8	32.9		
30	12.3	15.2	16.8	18.4	21.9	23.8	25.7	29.8	32.0	34.2		
40	13.1	16.2	17.8	19.6	23.3	25.3	27.3	31.7	34.0	36.4		
50	13.7	16.9	18.7	20.5	24.4	26.5	28.6	33.2	35.6	38.1		
60	14.3	17.6	19.4	21.3	25.4	27.5	29.8	34.5	37.0	39.6		

Note¹: For Building Category Definition See Page 104.

Note²: For Exposure Categories See Page 105.

Note³: Table conforms to ASCE 7-02.

Note⁴: For mean roof heights over 60 feet, engineering calculations must be submitted for permitting.

Table 5D
Category II Buildings
Exposure C - Coastal

Required Aerodynamic Uplift Moment, M_a (ft-lbf)												
Exposure C												
Monoslope Roofs (For Slopes $2\frac{1}{2}:12 < \theta < = 6\frac{3}{4}:12$)												
Height (ft) above ground level, z	Basic Wind Speed, V; (mph)											
	90	100	105	110	120	125	130	140	145	150		
Standard or Special Occupancy Structures having an Importance Factor of 1.00												
0 - 15	16.4	20.3	22.3	24.5	29.2	31.7	34.3	39.7	42.6	45.6		
20	17.4	21.5	23.7	26.1	31.0	33.7	36.4	42.2	45.3	48.5		
25	18.3	22.6	24.9	27.3	32.5	35.3	38.1	44.2	47.5	50.8		
30	19.0	23.5	25.9	28.4	33.8	36.6	39.6	46.0	49.3	52.8		
40	20.2	24.9	27.5	30.2	35.9	38.9	42.1	48.8	52.4	56.1		
50	21.2	26.1	28.8	31.6	37.6	40.8	44.1	51.2	54.9	58.8		
60	22.0	27.1	29.9	32.8	39.1	42.4	45.9	53.2	57.1	61.1		
Essential or Hazardous Facilities having an Importance Factor of 1.15												
0 - 15	18.9	23.3	25.7	28.2	33.6	36.4	39.4	45.7	49.0	52.5		
20	20.1	24.8	27.3	30.0	35.7	38.7	41.9	48.5	52.1	55.7		
25	21.0	26.0	28.6	31.4	37.4	40.6	43.9	50.9	54.6	58.4		
30	21.8	27.0	29.7	32.6	38.8	42.1	45.6	52.9	56.7	60.7		
40	23.2	28.7	31.6	34.7	41.3	44.8	48.4	56.2	60.3	64.5		
50	24.3	30.0	33.1	36.3	43.3	46.9	50.8	58.9	63.2	67.6		
60	25.3	31.2	34.4	37.8	44.9	48.8	52.7	61.2	65.6	70.2		

Note¹: For Building Category Definition See Page 104.

Note²: For Exposure Categories See Page 105.

Note³: Table conforms to ASCE 7-02.

Note⁴: For mean roof heights over 60 feet, engineering calculations must be submitted for permitting.

Roof Tile Attachment Resistance Values

Table 6

Profile	15/32" Decking, Direct to Deck	Uplift Capacity (ft.lbs.)
Flat/Low	1 - 10d Smooth or Screw Shank, 1 Clip	25.2
Medium	1 - 10d Smooth or Screw Shank, 1 Clip	25.2
High	1 - 10d Smooth or Screw Shank, 1 Clip	35.5
Flat/Low	2 - 10d Smooth or Screw Shank, 1 Clip	38.1
Medium	2 - 10d Smooth or Screw Shank, 1 Clip	38.1
High	2 - 10d Smooth or Screw Shank, 1 Clip	44.3
Flat/Low	2 - 10d Ringshank Nails, 1 (18-22 rings per inch)	39.1
Medium	2 - 10d Ringshank Nails, 1 (18-22 rings per inch)	36.1
High	2 - 10d Ringshank Nails, 1 (18-22 rings per inch)	28.6
Flat/Low	1 - #8 Screw	39.1
Medium	1 - #8 Screw	33.2
High	1 - #8 Screw	28.7
Flat/Low	2 - #8 Screw	50.2
Medium	2 - #8 Screw	55.5
High	2 - #8 Screw	51.3

Table 7

Profile	15/32" Decking, With Battens	Uplift Capacity (ft.lbs.)
Flat/Low	1 - 10d Smooth or Screw Shank, 1 Clip	27.5
Medium	1 - 10d Smooth or Screw Shank, 1 Clip	27.5
High	1 - 10d Smooth or Screw Shank, 1 Clip	29.4
Flat/Low	2 - 10d Smooth or Screw Shank, 1 Clip	37.6
Medium	2 - 10d Smooth or Screw Shank, 1 Clip	37.6
High	2 - 10d Smooth or Screw Shank, 1 Clip	47.2
Flat/Low	2 - 10d Ringshank Nails, 1 (18-22 rings per inch)	24.6
Medium	2 - 10d Ringshank Nails, 1 (18-22 rings per inch)	36.4
High	2 - 10d Ringshank Nails, 1 (18-22 rings per inch)	26.8
Flat/Low	1 - #8 Screw	25.6
Medium	1 - #8 Screw	30.1
High	1 - #8 Screw	25.5
Flat/Low	2 - #8 Screw	36.1
Medium	2 - #8 Screw	41.9
High	2 - #8 Screw	37.1

Table 8

Profile	19/32" Decking, Direct to Deck	Uplift Capacity (ft.lbs.)
Flat/Low	2 - 10d Ringshank Nails, 1 (18-22 rings per inch)	46.4
Medium	2 - 10d Ringshank Nails, 1 (18-22 rings per inch)	45.5
High	2 - 10d Ringshank Nails, 1 (18-22 rings per inch)	41.2

Table 9

Profile	15/32" Decking, Direct to Deck	Uplift Capacity (ft.lbs.)
Flat/Low	2 - 10d Ringshank Nails, With 2.5" Nail Hole	50.3
Medium	2 - 10d Ringshank Nails, With 2.5" Nail Hole	43.0
High	2 - 10d Ringshank Nails, With 2.5" Nail Hole	33.1

Note¹: Conforms to SSTD - 11

Table 10
For Adhesive-Set and Mortar-Set Roof Tile Attachment Only
and
All Hip and Ridge Tile Attachment

Attachment Resistance Limitations - See Note⁴		
Profile	15/32" or 19/32" Decking, Direct to Deck	Uplift Resistance Values
Flat/Low	Adhesive Based Systems	See Note ¹
Medium	Adhesive Based Systems	See Note ¹
High	Adhesive Based Systems	See Note ¹
Flat/Low	Mortar Based Systems	See Note ²
Medium	Mortar Based Systems	See Note ²
High	Mortar Based Systems	See Note ²
Flat/Low	Propriety Mechanical Fastening Systems	See Note ³
Medium	Propriety Mechanical Fastening Systems	See Note ³
High	Propriety Mechanical Fastening Systems	See Note ³

Note¹: Please contact adhesive manufacturer for approved uplift resistance values
 This system produces product specific results based on laboratory testing of the type of adhesive (one or two component) and the placement of adhesive.

Note²: Please contact mortar manufacturer for approved uplift resistance values
 This system produces product specific results based on laboratory testing of the composition and placement of mortar.

Note³: Please contact roof tile or fastener manufacturer for approved uplift resistance values
 This system produces product specific results based on laboratory testing of the type and placement of fasteners.

Note⁴: For mean roof heights over 60 feet, engineering calculations must be submitted for permitting.

Hip and Ridge Support Member Attachment Recommendations

How to use Table 11:

1. Determine the Exposure Category (See Page 105).
2. Determine the thickness of the roof sheathing.
3. Determine the basic wind speed.
4. Follow the rows to the right, based on the information gathered from steps 1 through 3 above. Under the appropriate basic wind speed column, lists the center-to-center spacing based on either a ¾” strap using 1 screw or an 1 ½” strap using 2 screws.

Table 11

Category II Buildings

Hip and Ridge Support Member Attachment Recommendations

Roof Sheathing (inches)	Exposure	Number of Fasteners on each side of Ridge Board	Strap Width	Basic Wind Speeds, V (mph)					
				100	110	120	130	140	150
				Center to Center Spacing (inches)					
15/32"	B	1 - #8	¾"	36	29	25	21	18	16
		2 - #8	1-1/2"	48	48	43	36	31	27
	C	1 - #8	¾"	27	22	18	16	13	12
		2 - #8	1-1/2"	46	38	32	27	23	20
19/32"	B	1 - #8	¾"	38	32	24	22	19	17
		2 - #8	1-1/2"	48	48	43	36	31	27
	C	1 - #8	¾"	29	24	20	17	14	12
		2 - #8	1-1/2"	46	38	32	27	23	20

Note¹: For Building Category Definition See Page 104.

Note²: For Exposure Categories See Page 105.

Note³: Table conforms to ASCE 7-02. Essential or Hazardous Facilities having an Importance Factor of 1.15

Note⁴: Table is good for Gable and Hip Roofs for Roof Slopes 2:12 < θ <= 12:12. Monoslope roof slopes are not addressed.

Note⁵: For mean roof heights over 60 feet, engineering calculations must be submitted for permitting.

Notes:

1. These measurements were based on actual center-to-center spacing.
2. Minimum thickness of roof sheathing shall be 15/32”.
3. Steel straps shall have a minimum tensile strength (F_u) for cold-rolled steel of 42 ksi and a minimum Design yield strength (f_y) for cold-rolled steel of 25 ksi conforming to one of the following ASTM A 606; ASTM A 607; ASTM A 611; ASTM A 653; ASTM A 715; and ASTM A 792.
4. Minimum thickness of steel straps shall be 26 gauge (0.0179”) before application of corrosion Resistance protection.
5. #8 wood screws are to conform to ASME / ANSI B18.6.1.
6. #8 wood screws shall have a minimum end distance, an edge distance, and a minimum distance between screws of ½”. The distance is to be measured to the center of the screw.
7. Table 11 is for Category II buildings with a mean roof height of 60’ or less.
8. The building is not located on isolated hills, ridges, or escarpments, constituting Abrupt changes in general topography, which creates wind speed-up effects.

GLOSSARY

GLOSSARY OF TERMS AND DEFINITIONS

The terms and definitions herein are used in the context of Concrete and Clay Tile Roofing. It should be understood by the reader that some of the terms and definitions included herein may also have different meanings/interpretations when used in context with other types of Roof Constructions, Coverings, Roofing Materials/Systems.

AERODYNAMIC MOMENT - A quantity which expresses the effect of a force applied at a particular point in relation to a specific point or axis.

ANCHOR SHEET - The first sheet applied to a roof deck by nailing, mopping or other approved attachment, often called a 'base sheet'.

ANTI-PONDING - A method to ensure positive drainage over raised fascia/starter strip at eave.

APA - American Plywood Association.

APRON FLASHING - A flexible or rigid flashing installed at head of tile onto a vertical surface.

APPLICATION RATE - The quantity (mass, volume or thickness) of material applied per unit area.

APPROVED PRODUCTS - Includes all products tested and evaluated for the approved application.

ASCE - American Society of Civil Engineers.

ASPHALT - A bituminous waterproofing agent applied to roofing materials during the manufacturing process or in the assembly/construction of a roof covering.

ASPHALT FELT - An asphalt saturated felt or an asphalt coated felt.

ASPHALT ROOFING CEMENT - A mixture of asphaltic materials, solvents and graded mineral, organic or inorganic fillers.

ASPHALT TYPE III - Also referred to as 'STEEP ASPHALT'. It is a grade of asphalt designed for sloped roofing applications and complying with ASTM SPECIFICATION D 312, TYPE III.

ASPHALT TYPE IV - Also referred to as 'SPECIAL STEEP ASPHALT'. It is a grade of asphalt designed for sloped roofing applications complying with ASTM D 312, TYPE IV.

ASTM - American Society for Testing and Materials.

AWPA - American Wood Preservers Association.

BACKNAILING - The practice of nailing roll roofing such that the nails are placed in the underlying roofing and are covered by the overlapping course of roll roofing.

BASE FLASHING - That portion of the flashing attached to or resting on the roof surface or deck to direct the flow of water onto the roof covering.

BASE SHEET - The bottom or first ply of a roof system assembly over which subsequent roofing plies are applied.

BATTEN EXTENDER - Product designed to cantilever to center of valley and/or wall tray, nailed to batten with no penetration through metal designed to elevate tile above valley and flashing.

BATTENS - Fastening strips installed to the underlayment or sub-roof to which roof tiles are then installed.

BEDDING - Refers to the installation of roof tiles with mortar or polyurethane foam paddy and is structural in nature for basic securement.

BOND - The adhesive and cohesive forces holding two roofing components in intimate contact.

CAP SHEET - Top or final ply of an underlayment system.

CLOSED VALLEY - (SEE VALLEYS).

COLD PROCESS ROOFING - A continuous semi-flexible membrane consisting of plies of felts, mats or fabric that are laminated on a roof with alternate layers of cold-applied mastic.

CONCEALED NAIL METHOD - (SEE BACKNAILING).

COURSE - A row of tiles or roll roofing running parallel to the eave.

COUNTER FLASHING - A rigid or flexible material secured on or into a wall, curb, pipe, rooftop unit or other surface to cover and protect the upper edge of a base flashing and its associated fasteners.

COVERAGE - The surface area (in square feet) to be continuously covered by a specific roofing material, with allowance made for a specific lap.

CRICKET - A peaked saddle construction located at the back (high side) of a chimney (or other appurtenance) to deflect the flow of water around the chimney.

CROSS BOND METHOD - A method of installing tiles such that the side laps of the tiles are staggered to the preceding course.

DECK - The surface installed over the structural framing members to which roofing is applied. Another name for sheathing. May be of wood boards, plywood or other approved material.

DRIP EDGE - A non-corrosive material (usually of galvanized steel sheet metal, stainless steel, copper or aluminum) used along the roof perimeter to allow water run-off to drip clear of the underlying construction.

EAVE - The horizontal lower edge of a sloped roof.

EAVE CLOSURE - A prefabricated EPDM rubber, metal, concrete or clay material or mortar to elevate the first course of tiles and to enclose the cavity formed by the tiles at the eave.

FABRIC - A woven cloth of organic or inorganic filaments, threads or yarns. The prevailing types are either cotton or fiberglass (also often referred to as “membrane”).

FASCIA - An ornamental board used to cover the rafter or truss end at the eave.

FELT - A flexible or semi-flexible sheet manufactured for use as an underlayment.

FISHMOUTH - A half-cylindrical or half-conical opening formed by an edge wrinkle in felt or roll roofing materials.

FLANGE - The projecting edge of a rigid or semi-rigid component, such as a metal flashing flange, skylight flange, flashing boot flange, etc.

FLASHING - A rigid or flexible material used to prevent water infiltration at roof projections and to redirect water from walls, chimneys, valleys, etc.

FLASHING CEMENT - A premium grade of asphalt roofing cement (SEE ASPHALT ROOFING CEMENT).

FLAT/LOW PROFILE TILE - Defined as those tiles with less than a 1/2 inch rise.

FOAM PADDY - A prepared polyurethane foam adhesive mixture used to adhere a roof tile to the underlayment.

FRSA - Florida Roofing, Sheet Metal and Air Conditioning Contractors Association.

GABLE - The generally triangular section at the end of a pitched roof occupying the space between the two slopes.

GALVANIZED - A zinc coating to prevent the rusting of steel or iron.

HEAD LAP - 1. The dimension by which the overlap of the nose end of a tile covers the head end of tile in the row of tiles immediately under it. 2. The dimension by which a course of the underlayment overlaps the preceding course.

HIGH PROFILE TILE - High profile shaped tiles are defined as those tiles having a rise to width ratio greater than 0.20.

HIP - The inclined external angle formed by the intersection of two sloping planes of the roof.

HIP AND/OR RIDGE BOARD - Wood or metal frame installed on a hip or ridge to provide a surface for installation of hip and ridge tiles.

HOT MOP SYSTEM - Refers to a multi-ply sub roof system where one or more plies are adhered to an anchor sheet in hot asphalt.

HURRICANE CLIPS - (SEE STORM CLIP)

INTERLOCKING TILE - Those tiles with a system of ribs or grooves enabling the lateral joining of adjacent tiles in the same horizontal course, with the over lapping lock covering the under lapping lock.

“L” FLASHING - (SEE FLASHING)

MASTIC - (SEE ASPHALT ROOF CEMENT)

MEAN ROOF HEIGHT - The average elevation above grade height measured between the eave and ridge of a roof area.

MEDIUM PROFILE TILE - Medium profile tiles are defined as those tiles having a rise to width ratio less than or equal to 0.20.

MEMBRANE - (SEE FABRIC)

MINERAL SURFACED ROLL ROOFING - A prepared organic felt with granular surfaced finish, minimum 74# per 100 square feet, commonly called 90# or No. 90.

MODIFIED BITUMEN - Are composite sheets consisting of a copolymer modified bitumen often reinforced and sometimes surfaced with various types of fibers, foils and mats.

MORTAR PADDY - A prepared mortar mixture used to adhere a roof tile to the underlayment.

NINETY-POUND ROLL ROOFING (90#) - (SEE MINERAL SURFACED ROLL ROOFING)

NON-INTERLOCKING TILE - Those tiles without restrictive ribs, grooves or channels at the side laps.

NTRMA - National Tile Roof Manufacturers Association.

OPEN VALLEY - (SEE VALLEYS)

OVERHANG - That portion of the tile which extends beyond the eave.

PAN FLASHING - Similar in profile shape to an “L” flashing, but with a return designed/fabricated to the outside horizontal edge. This type of flashing is used to contain water flow.

PHASED APPLICATION - The installation of a roof system or waterproofing system during two or more set time intervals.

PITCH - The degree of roof incline expressed as a ratio of the rise, in feet to the span, in feet.

PLASTIC CEMENT - (SEE ASPHALT ROOF CEMENT)

PLY - The number of layers of roofing, i.e. one-ply, two-ply.

POINT-UP - The application of mortar to fill voids to various ends, sides and angles of a tile roof, which are non structural in nature.

RAFTER - The supporting framing member immediately beneath the deck, sloping from the ridge to the wall plate.

RAKE - The outside edge of a sloped roof at the gable.

REGLET - A groove in a wall or other surface adjoining a roof surface for the use of installing a counterflashing.

RIDGE - The uppermost horizontal external angle formed by the intersection on two sloping planes of the roof.

RIDGEBOARD - (SEE HIP AND RIDGE BOARD)

SADDLE - A small structure that helps channel water to a point or around an obstruction. (SEE CRICKET)

SATURATED FELT - A roofing felt that had been partially saturated with asphalt.

SELVAGE -Need Definition

SHEATHING - Exterior grade wood boards used as a roof deck material.

SIDE LAP - The width of the section of a tile containing the under lap.

SKIRT FLASHING - A rigid or flexible flashing used to redirect water from a preformed flashing onto the tile surface.

SLOPE - The degree of roof incline expressed as a ratio of the rise in inches to the run in inches.

SLIPPAGE - Relative lateral movement of roll roofing installed on sloped roof often occurring due to not having backnailed the roll roofing.

SOAKER FLASHING - A rigid or flexible flashing used at intersecting planes.

SOIL PIPE - A vent pipe that penetrates the plane of the roof.

STORM CLIPS - A device attached near or on the nose end of a tile to inhibit the uplift forces of wind.

STRAIGHT BOND METHOD - A method of installing tiles such that the side laps of the tiles are in direct line to the preceding course.

SQUARE - A unit of roof measure equivalent to 100 square feet.

SWEAT SHEET - The first ply of underlayment installed the length of a valley prior to the application of subsequent horizontal plies.

TRI - Tile Roofing Institute, formally the (RTI) Roof Tile Institute and the (NTRMA) National Tile Roofing Manufacturers Association.

TAPERED CANT STRIP - A beveled strip used for support behind a raised fascia or starter strip to modify the angle at the eave.

TIN TAG - A small sheet metal disc through which a fastener is driven into the substrate to secure underlayment.

UNDERLAYMENT - One or more water shedding layers of roofing applied to a sloped roof prior to the installation of roof tiles.

VALLEY - The internal angle formed by the intersection of two sloping roof planes.

VALLEYS, TILE INSTALLATION METHODS:

CLOSED VALLEY - A method of installing roof tiles where tiles are cut, mitered and installed to a close tight fit.

OPEN VALLEY - A method of installing roof tiles where tiles are cut, mitered and installed such that a gap or trough is created to assist in the flow/drainage of water run-off.

VENT - Any outlet for air that protrudes through the roof deck.

WEEP HOLE - Openings in the eave closure and/or certain ridge conditions that allow for moisture drainage and air ventilation.

**INSTRUCTIONS
FOR
HIP AND RIDGE ATTACHMENT SECTIONS
OF THE
FRSA/TRI “CONCRETE AND CLAY ROOF TILE
INSTALLATION MANUAL” Fourth Edition**

**FOR USE BY
AUTHORITIES HAVING JURISDICTION**

**Submitted by the
FRSA/TRI TILE COMMITTEE**

REVISED: August 3, 2005

Foreword

These recommendations were developed after surveying the recent hurricanes and with input from the code, roofing and tile manufacturing community. They are designed to further clarify the current installation procedures as they pertain to the specific roof tile systems (Mechanically fastened, Adhesive-set or Mortar-set).

The following recommendations provide for only products approved by the FBC (Florida Building Code), tested according to SSTD-11 and verified by third party independent FBC approved laboratories, to determine the wind uplift limitations of the various hip and ridge attachment methods or by installation methods currently recognized in the HVHZ (High Velocity Hurricane Zone) section of the FBC.

A joint sub-committee consisting of members from the FRSA (Florida Roofing, Sheet Metal and Air Conditioning Contractors Association, Inc) and the TRI (Tile Roofing Institute) drafted these recommendations and they were approved by consensus by the FRSA Roof Tile Committee.

Table of Contents

1. Introduction	4
1.1 Purpose.....	4
1.2 Scope.....	4
1.3 Basis for Requirements.....	4
1.4 Applicable Documents.....	5
1.5 Acronyms, Definitions and General Assumptions	5
2. General Information	6
2.1 Hip and Ridge Attachment Information.....	6
2.2 Approval Ratings and Limitations.....	7
3. General Requirements	7
3.1 Review of Documents.....	7
3.2 Markings.....	8
3.3 Manufacturer’s Installation Instructions.....	8
3.4 Qualified Applicator Program.....	8
4. Hip and Ridge Attachments	8
4.1 Hip and Ridge Attachment descriptions.....	8
4.2 Field Cut Roof Tile Requirements.....	9
4.3 Hip and Ridge/Field Tile System Limitations.....	9
5. Mechanically Attached Hip and Ridge Tile	11
5.1 Mechanically Attached Hip and Ridge Tile – Structural Support Options.....	11
5.2 Weather Blocking Options.....	13
5.3 Hip and/or Ridge Starter Tile Attachment.....	18
5.4 Hip and Ridge Tiles Mechanically Attached to Structural Support.....	19
6. Adhesive-set Hip and Ridge Attachment System	19
6.1 Adhesive-set Hip and Ridge Attachment System- Structural Support Options.....	19
6.2 Adhesive Weather Blocking System Options.....	20
6.3 Adhesive-set Hip and Ridge Starter Tile Attachment.....	22
6.4 Adhesive-set Hip and Ridge Tile Attachment.....	22
7. Mortar-set Hip and Ridge Tile Attachment System	24
7.1 Mortar-set Hip and Ridge Tile Attachment System.....	24
7.2 Mortar-set Hip and Ridge Starter Tile Attachment.....	24
7.3 Mortar-set Hip and Ridge Tile Attachment.....	26
Appendix A: Hip and Ridge Board Attachment Instructions – Table 11	30

1. Introduction

1.1. Purpose

- 1.1.1. This document is to be used as a supplement to the FRSA/TRI “Concrete and Clay Roof Tile Installation Manual” - Fourth Edition, specifically the sections of Systems 1, 2, 3 and 4, pertaining to hip and ridge attachment. Recent wind events have established the need to provide greater attention to hip and ridge attachment systems. In order to prevent similar occurrences, all hip and ridge attachment systems must be tested to show compliance to the wind loads set forth by the FBC. The test results will establish the mean roof height limitations for each of the hip and ridge attachment systems. The prescriptive method of hip and ridge applications will no longer be accepted.

1.2 Scope

- 1.2.1 These recommendations set the requirements for the hip and ridge attachment for Systems 1, 2, 3 and 4 of the FRSA/TRI “Concrete and Clay Roof Tile Installation Manual” - Fourth Edition.
- 1.2.2 These recommendations and any other newly developed recommendation shall be tested under laboratory conditions according to SSTD-11 to determine the wind uplift resistance of the specific hip and ridge attachment system. An additional tile factor of 2-to-1 above that specified in SSTD-11 or TAS 101 shall be applied in determining the ‘allowable overturning moment’ or ‘attachment resistance expressed as a moment (Mf)’ to account for any interdependence hip and ridge attachment methods used.
- 1.2.3 The wind resistance performance of the hip and ridge system depends in part on its ability to resist the uplift forces at the perimeter edge and the attachment of the adjoining field tile.
- 1.2.4 These recommendations are not intended to determine which hip and ridge system is more or less suitable for the user of the product. Conditions, under which the hip and ridge attachment system is used, vary widely. It is the ability of the manufacturer and the user to determine the suitability of the hip and ridge system for the intended job location.
- 1.2.5 These recommendations are not intended to determine which hip and ridge system is more or less suitable as a weather blocking system or the system’s ability to restrict or prevent the infiltration of air or water into the tile system. It is the responsibility of the user to determine the most effective weather blocking system for the intended job location.

1.3 Basis for Requirements

- 1.3.1 These recommendations are based on experience, research and testing and/or the standards of other organizations. The advice of manufacturers, users, and trade associations was also considered.

- 1.3.2 These recommendations prohibit component substitution without proper laboratory testing and a FBC Product Approval.
- 1.3.3 The recommendations reflect tests and practices used to examine characteristics of hip and ridge attachment. These recommendations are intended as guides and strict conformity is not always mandatory. Hip and ridge attachment systems having characteristics not anticipated by these recommendations may be satisfactory if performance equal or superior to that required by these recommendations is demonstrated.

1.4 Applicable Documents

- 1.4.1 FRSA/TRI ‘Concrete and Clay Roof Tile Installation Manual’ – Fourth Edition
- 1.4.2 (FBC) Florida Building Code
- 1.4.3 Chapter 9B-72 - Department of Community Affairs – Florida Building Commission
- 1.4.4 SSTD-11 – ‘SBCCI Test Standard for Determining Wind Resistance of Concrete or Clay Roof Tiles’
- 1.4.5 (TAS) Testing Application Standard 101 – 95 – ‘Test Procedure for Static Uplift Resistance of Mortar or Adhesive Set Tile Systems’

1.5 Acronyms, Definitions and General Assumptions

- 1.5.1 FBC – Florida Building Code.
- 1.5.2 HVHZ – High Velocity Hurricane Zone of the FBC.
- 1.5.3 FRSA – Florida Roofing, Sheet Metal and Air Conditioning Contractors Association, Inc.
- 1.5.4 TRI - Tile Roofing Institute, formally the (RTI) Roof Tile Institute and the (NTRMA) National Tile Roofing Manufacturers Association.
- 1.5.5 Code Approved – Any product that has FBC Product Approval for that specific application.
- 1.5.6 Structural support – Any (wood, metal, or other code approved) product used as a means to transfer the loads of an attached hip and ridge tile to the substrate.
- 1.5.7 Job-site mix – Any non pre-bagged mortar meeting ASTM C-270 for cement, sand and proportioning mixed at a job site and not bagged under the quality control of the mortar manufacture.
- 1.5.8 Pre-bagged Mortar – Any mortar where the proportions are mixed and bagged under the quality control of the mortar manufacturer and has been issued a FBC Product Approval, tested to SSTD-11.

- 1.5.9 FRSA/TRI Manual – The FRSA/TRI ‘Concrete and Clay Roof Tile Installation Manual’ – Fourth Edition.
- 1.5.10 Roof Tile Adhesive – A roof tile adhesive product that has been issued FBC Product Approval, tested to SSTD-11.
- 1.5.11 2” x (H) - a nominal 2” wide by any height (H) necessary to accommodate and properly install the attachment of the hip and ridge tiles. The height of the structural support will vary due to tile profile and the pitch of the roof.

2. General Information

2.1. Hip and Ridge Attachment System Information

- 2.1.1. Hip and ridge attachment systems are used for weather blocking at the terminations of two adjoining roof planes. Experience has shown that adequate attachment of the hip and ridge tile systems is extremely important to maintaining weather blocking and to minimize ancillary missiles from being created which may occur when hip and ridge tiles impact the field roof tile. Adequately secured field tiles may be vulnerable to wind damage if the hip and ridge tile system is improperly installed. To achieve the specified wind uplift results, follow the hip and ridge application procedures, which shall be representative of the tested assembly.
- 2.1.2. Hip and ridge attachment system failures occur when wind uplift or pressure exerts forces beyond the resistance strength of the hip and ridge attachment and/or of the structural support to the substrate. When the hip and ridge tile and/or the adjoining field tile are not properly secured, the resulting prying action and uplift forces may cause the hip and ridge attachment to fail. When this occurs the roof tile system becomes vulnerable and may cause ancillary damage and may subject the building to additional rain and/or additional roof tile securement damage.
- 2.1.3. Hip and ridge tile systems must adequately terminate the adjoining planes. There are three basic types of weather blocking methods used in Florida, foil-faced self-adhered membrane, adhesive and mortar:

Foil-faced self-adhered Membrane System is typically used when a wood hip and ridge frame has been secured to the substrate, the foiled backed membrane is applied in a step fashion sealing to both sides of the adjoining field tile planes prior to the mechanically attachment to the wood frame. It can also be used on a metal hip and ridge frame where mechanical attachment of the hip and ridge tile is an acceptable attachment method. Can be used with all roof tile systems.

Adhesive is used to weather block the entire cavity of the adjoining planes of field tile to the sides of the structural support. Can be used with all roof tile systems.

Mortar (pre-bagged or job-site mix) is used to weather block the longitudinal edges of the hip and ridge tiles to the adjoining field tile roof planes. Can be used with all tile systems.

- 2.1.4 Hip and Ridge tiles must be adequately attached to transfer the loads to the substrate. **There are three basic attachment methods of the hip and ridge tiles** used in Florida, mechanical attachment, adhesive-set and mortar- set attachment systems:

Mechanical Attachment is the securement of the hip/ridge tiles with nails or screws at the head of the tile in addition to a FBC approved adhesive at the hip/ridge tile overlaps.

Adhesive-set is the securement of the hip/ridge tiles to a structural support with a full bed of adhesive or other FBC approved paddy method.

Mortar-set is the securement of the hip/ridge tiles along both longitudinal edges of the adjoining planes of field tile embedded in a full bed of **pre-bagged FBC approved mortar only**.

- 2.1.5 Hip and Ridge tile attachment methods are also categorized by whether or not the attachment system is an independent attachment system or an interdependent attachment system. An example of an independent attachment is when the hip/ridge tile is attached in a full bed of adhesive or mortar. An interdependent attachment system is when the load is being applied to more than one tile. An example is a mechanical fastener used at the head of the hip/ridge tile and adhesive used at the overlap joining both tiles together. When the load is being applied to the hip/ridge tile, the resistance is shared with the nail installed at the head of the tile and the adhesive at the hip/ridge tile overlap, which is transferring the load to the nail of the previously installed hip tile.

2.2. Approval Ratings and Limitations

- 2.2.1. The uplift resistance values achieved from the laboratory testing shall determine the mean roof height limitation of the hip and ridge attachment system.
- 2.2.2. The resistance values for mechanical fasteners shall be posted in the roof tile manufacturers FBC Product Approval.
- 2.2.3. The resistance values for adhesive-set system shall be posted in the roof tile adhesive manufacturers FBC Product Approval.
- 2.2.4. The resistance values for mortar-set system shall be posted in the roof tile mortar manufacturers FBC Product Approval.

3. General Requirements

3.1. Review of Documents

- 3.1.1. The hip and ridge attachment system shall be installed according to these recommendations and confirmed by test data and/or manufacturers installation recommendation if the system test indicates otherwise or installed according to the HVHZ.

- 3.1.2. All hip and ridge attachment systems, with uplift resistance values and limitations shall be included in the FBC Product Approval or installed according to the HVHZ, with the same limitations applied.

3.2 Markings

- 3.2.1 The packaging for the hip and ridge attachment products shall bear the manufacturer's name, model number or trade name and the FBC Product Approval number.

3.3 Manufacturer's Installation Instructions

- 3.3.1 The manufacturer shall provide all the necessary application instructions, printed materials, and other assistance to the installer to ensure proper installation as required to produce the performance as tested for the FBC Product Approval. These instructions shall include uplift resistance values and clearly state any limitations required.

3.4 Qualified Applicator Program

- 3.4.1 The adhesive-set and mortar-set manufacturers shall provide a joint qualified applicator program.

4. Hip and Ridge Tile Attachment Systems

NOTE: This document was written for projects utilizing hip and ridge tile. For mitered hip and ridge applications refer to the tile manufacturers recommendations.

4.1 Hip and Ridge Tile Attachment Descriptions

- 4.1.1 There are four roof tile installation systems currently listed in FRSA/TRI 'Concrete and Clay Roof Tile Installation Manual, System One, System Two, System Three and System Four 'A' & 'B'. **Only System Three and System Four 'B' allows for the use of a FBC approved pre-bagged mortar to attach hip and ridge tiles without the use of a wood, metal or other structural support.**

The three (3) most common methods for installing hip and ridge tile are mechanically fastened, Adhesive-set and mortar-set attachment systems:

- 1) **Mechanically Fastened Hip and Ridge Attachment System** – This attachment system consists of installing typically a wood hip and ridge frame (or other structural support equal to or superior to resist the pullout of mechanical fastener) secured to the substrate according to the FRSA/TRI Concrete and Clay Roof Tile Installation Manual or the requirements of the HVHZ requirements of the (FBC) Florida Building Code, or having a FBC product approval meeting the requirements of the FBC, specifically rule 9B-72. The weather blocking mechanism is either accomplished with adhesive tested for a weather block, pre-bagged or job site mix mortar or with a step flashing using a foil-faced self-adhered membrane. The hip/ridge tiles are mechanically attached to the structural support with mechanical fasteners and a FBC code-approved roof tile adhesive at the hip/ridge tile overlaps.

- 2) **Adhesive-set Hip and Ridge Attachment System** - This attachment system consists of installing a wood or metal hip and ridge frame (or other structural support) secured to the substrate according to the FRSA/TRI Concrete and Clay Roof Tile Installation Manual or to the requirements of the HVHZ requirements of the (FBC) Florida Building Code, or having a FBC product approval meeting the requirements of the FBC, specifically rule 9B-72. The weather blocking mechanism is either accomplished with mortar or with a FBC code-approved roof tile adhesive or other FBC code-approved weather blocking material, designed and tested specifically for roof tile weather blocking applications. The hip/ridge tiles are attached to the structural support with a FBC approved adhesive according to the adhesive manufacturers recommendations based on the FBC approved independent laboratory testing or according to the requirements of the HVHZ requirements of the FBC. For slopes over 7:12, additional securement at the hip may be necessary to prevent tile movement until adhesive is cured.
- 3) **Mortar-set Hip and Ridge Attachment System** - This attachment system consists of installing hip and ridge tiles into a bed of FBC approved mortar tested specifically for hip and ridge tile applications and meet the requirements of the (FBC) Florida Building Code, specifically rule 9B-72. The mortar is used as the attachment and waterproofing mechanism. For slopes over 7:12, additional securement at the hip may be necessary to prevent tile movement until mortar is cured.

4.2 Field Cut Roof Tile Requirements

- 4.2.1 All field cut tiles (two tiles on each side of hip) and the top course of ridge must be attached to the substrate with code-approved adhesive, code-approved mortar or mechanical fasteners and adhesive. **(See Drawings 1 and 2)**. In situations where the ridge course of tile has been cut, the field cut tile and the full tile course below the cut tile must be attached to the substrate as well. This requirement is designed to minimize any dynamic movement of the field cut tiles, at the most stringent zones of the roof, which may occur during a high wind event such as hurricanes. **(See Drawings 3)**.
- 4.2.2 The minimum head lap when installing the hip and ridge tiles is 2”, as stated in the FRSA/TRI manual. It may be necessary to increase the head lap to cover exposed hip/ridge tile fastening holes or adhesive. Cover exposed fasteners with a UV resistant sealant.

4.3 Hip and Ridge/Field Tile System Limitations

- 4.3.1 There are three attachment methods for securing hip and ridge tile, mechanically attached, adhesive attached, and Mortar attached. These methods can only be used on field tile attachment systems as follows:
 - Mechanically Attached Hip and Ridge Tiles** - Can be used on field tile attachment Systems One, Two, Three and Four, as listed in the FRSA/TRI Manual.
 - Adhesive-set Hip and Ridge Tiles** - Can be used on field tile attachment Systems One, Two, Three and Four, as listed in the FRSA/TRI Manual.
 - Mortar-set Hip and Ridge Tiles** - Can be used on field tile attachment Systems Three and Four ‘B’ only, as listed in the FRSA/TRI Manual.

NOTE: Use only the hip/ridge attachment system that will meet or exceed the tile/wind loads set forth by the FBC.

Drawing 1

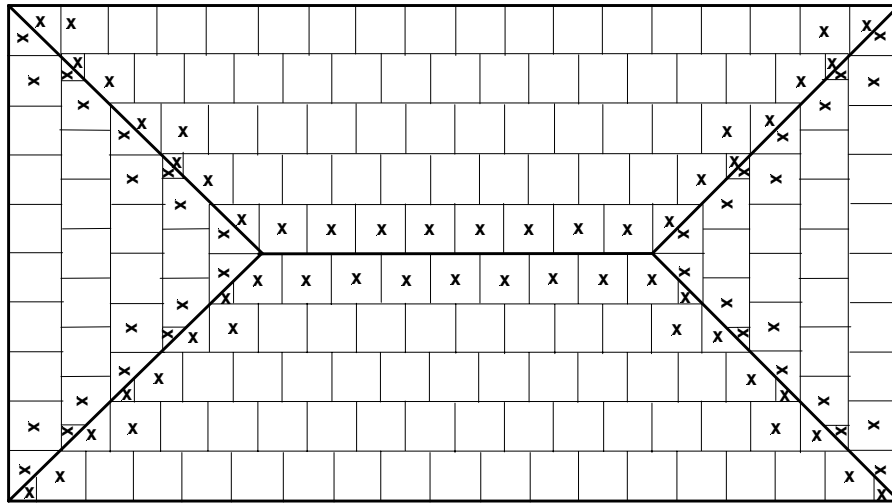

Flat/Low, Medium or Crossbond Tile Applications

Attach two tile each side of hip and one top ridge course to the underlayment with code approved roof tile adhesive, code approved mortar or mechanically attach with fasteners and code approved adhesive at the tile overlaps. When using adhesive or mortar to attach tile to the underlayment the underlayment must be approved for adhesive-set or mortar-set applications.

Drawing 2

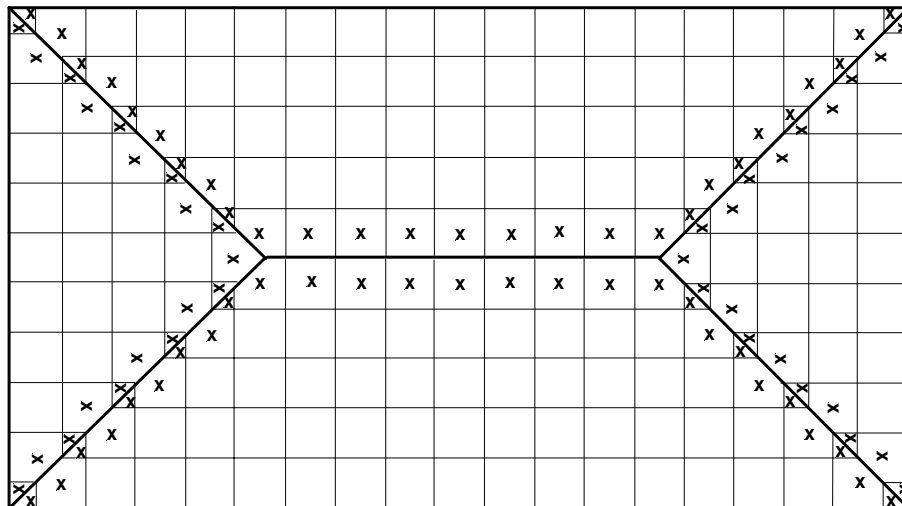

High Profile Tile or Straight Bond Tile Application

Attach two tile each side of hip and one top ridge course to the underlayment with code approved roof tile adhesive, code approved mortar or mechanically attach with fasteners and code approved adhesive at the tile overlaps. When using adhesive or mortar to attach tile to the underlayment the underlayment must be approved for adhesive-set or mortar-set applications.

Drawing 3

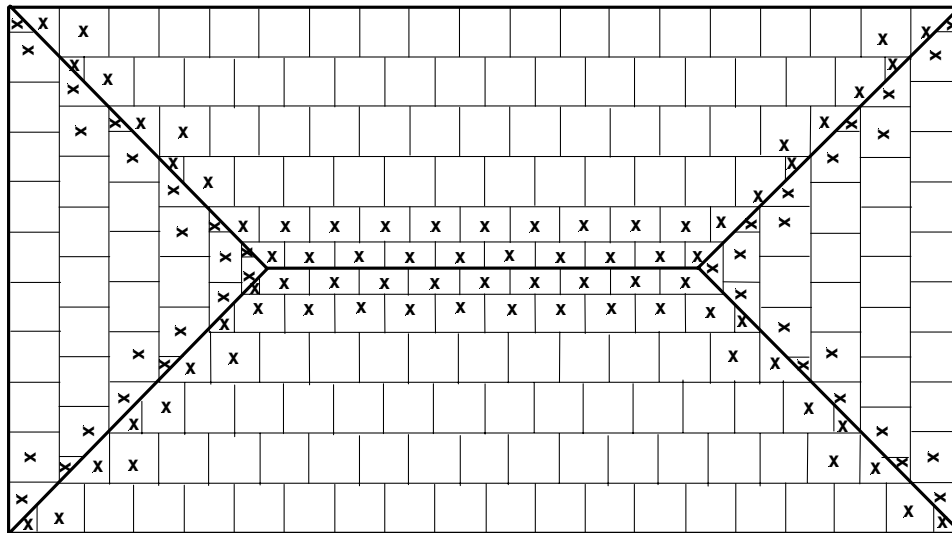

Cut Pieces at Ridge Line

Where field cut tiles are used at the ridge, attach the cut tile and full tile each side of top ridge course to the underlayment with code approved roof tile adhesive, code approved mortar or mechanically attach with fasteners and code approved adhesive at the tile overlaps. When using adhesive or mortar to attach the tile to the underlayment the underlayment must be approved for adhesive-set or mortar-set applications.

5. Mechanically Attached Hip and Ridge Tile

5.1. Mechanically Attached Hip and Ridge Tile - Structural Support Options

5.1.1. Determine how you want to attach the structural support to the substrate. The three most common methods to attach the structural support (typically wood) to the substrate are:

- 1) Metal Brackets – (See Drawing 4)
- 2) Metal Straps – (See Drawing 5)
- 3) Code-approved Adhesive – (See Drawing 6)

5.1.2 Attachment of the wood hip and ridge frame to the substrate must be according to Table 11 of the FRSA/TRI Concrete and Clay Roof Tile Installation Manual or according to the HVHZ requirements of the FBC. (See Appendix A for copy of the FRSA/TRI Manual Table 11).

Drawing 4

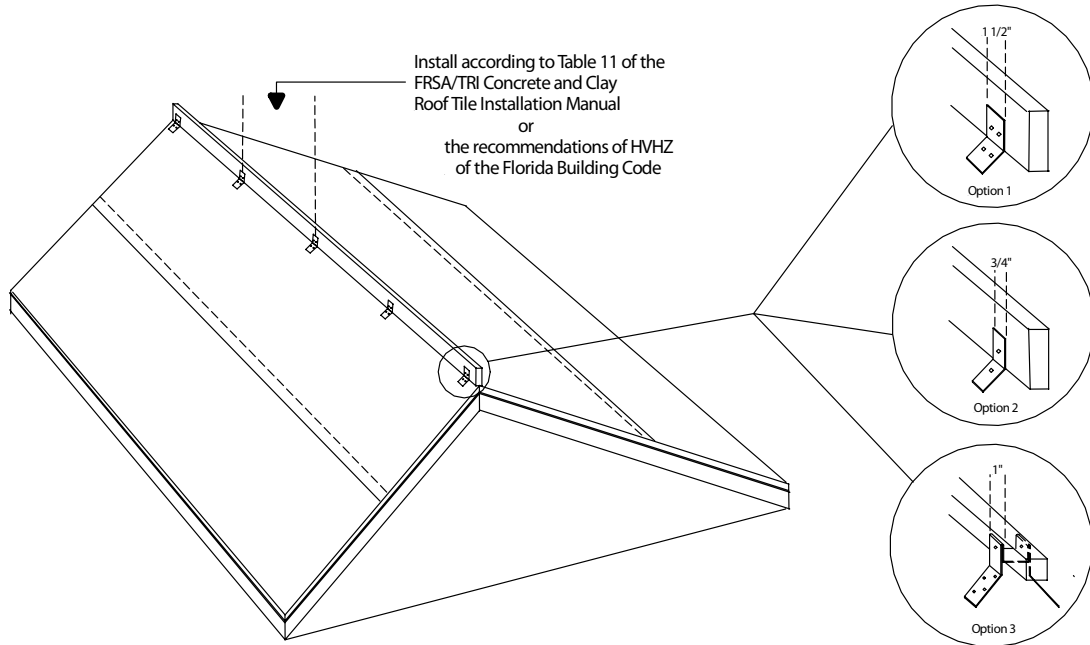

Mechanically Attached Wood Hip and Ridge Board Using Metal Brackets.

Drawing 5

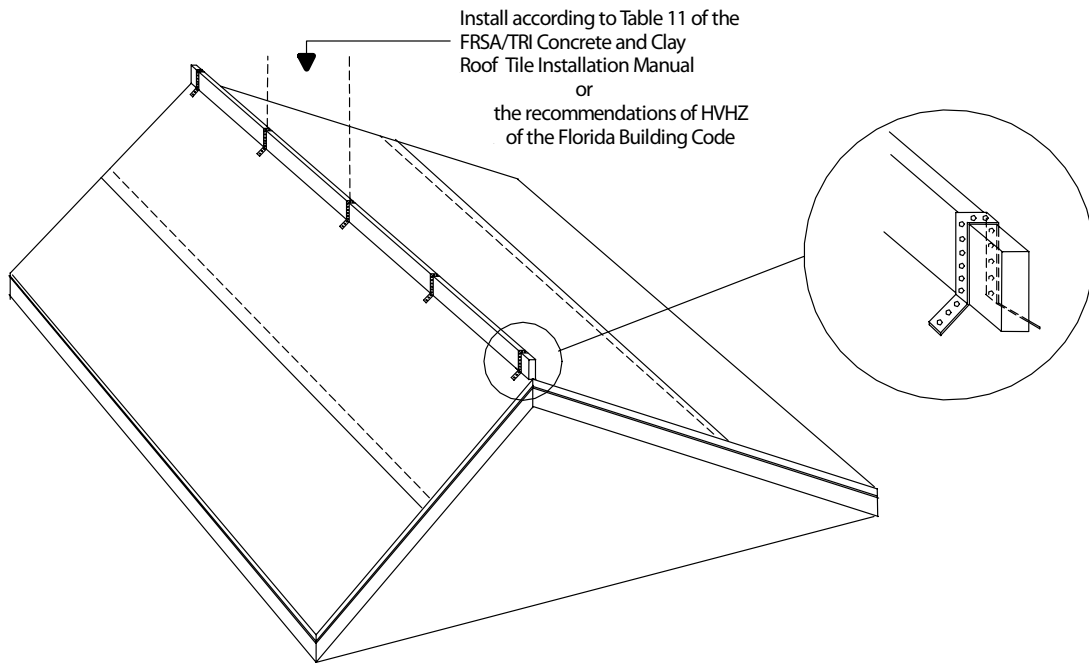

Mechanically Attached Wood Hip and Ridge Board using Strapping Method

Drawing 6

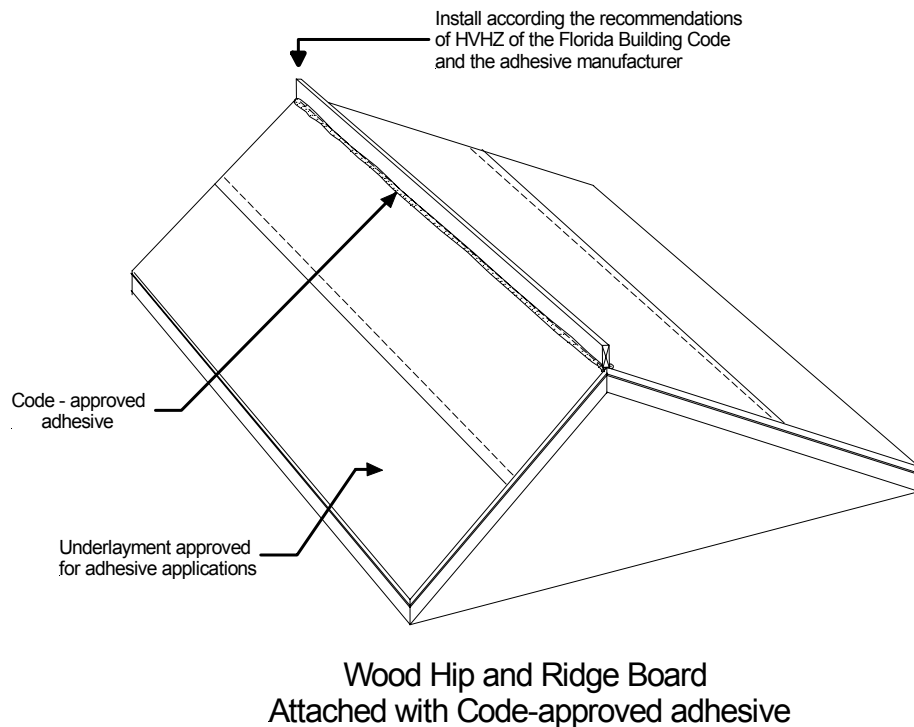

5.2 Weather Blocking Options

5.2.1. After completion of the structural support attachment choose the desired weather blocking method for the specific attachment system. The three most common weather blocking methods are:

- 1) Foil-faced Self-adhered Membrane Weather Blocking System
- 2) FBC Approved Adhesive Tested as a Weather Blocking System
- 3) (Pre-bagged or Jobsite Mix) Mortar Hip/Ridge Weather Blocking System

5.2.2. Foil-faced Self-adhered Membrane as a Weather Block.

5.2.2.1. This system uses self-adhered membrane as weather block. No mortar is used along the longitudinal edges of the tile. Mortar can be used at the hip/ridge, hip/valley, ridge/valley, and ridge/gable (etc) junctions as a weather block.

5.2.2.2. Install foil-faced self-adhered membrane over hip/ridge frame (foil side up) in a step flashing method per membrane manufacturer's recommendations and seal to field tile. **(See Drawings 7 & 8)**

5.2.2.3. Care should be taken to ensure the self-adhered membrane is sealed to the tile surface. Ensure hip/ridge, ridge/gable, ridge/valley and hip/eave junctions are sealed to prevent water entry of those areas.

Drawing 7

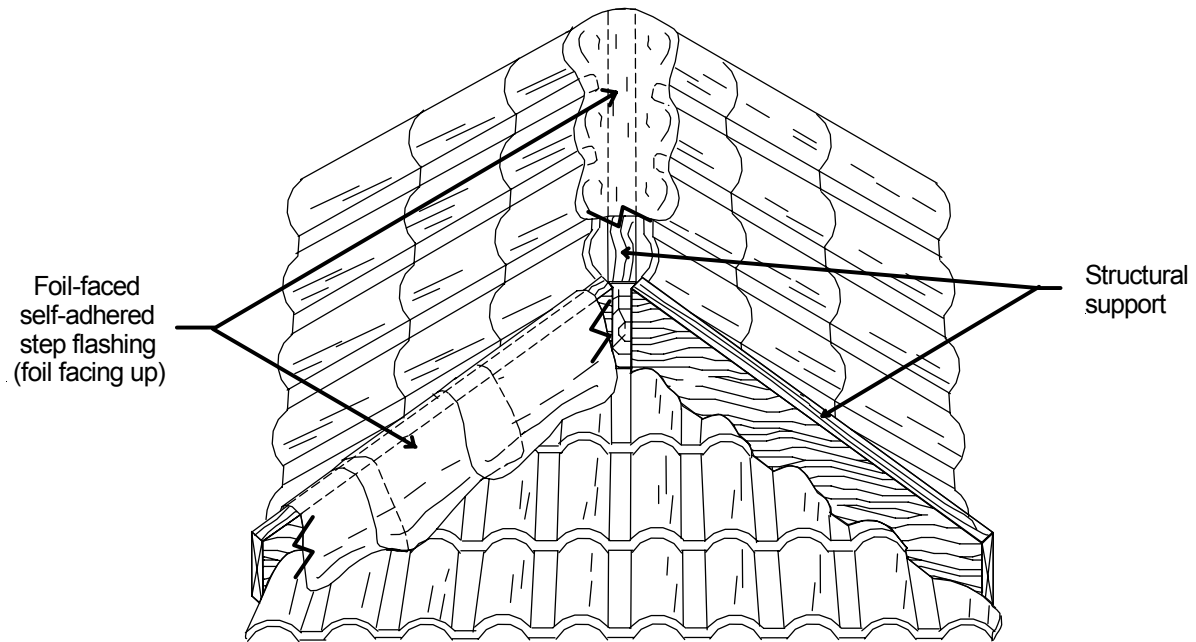

Foil-faced Self-adhered Membrane Used as a Weather Block

Drawing 8

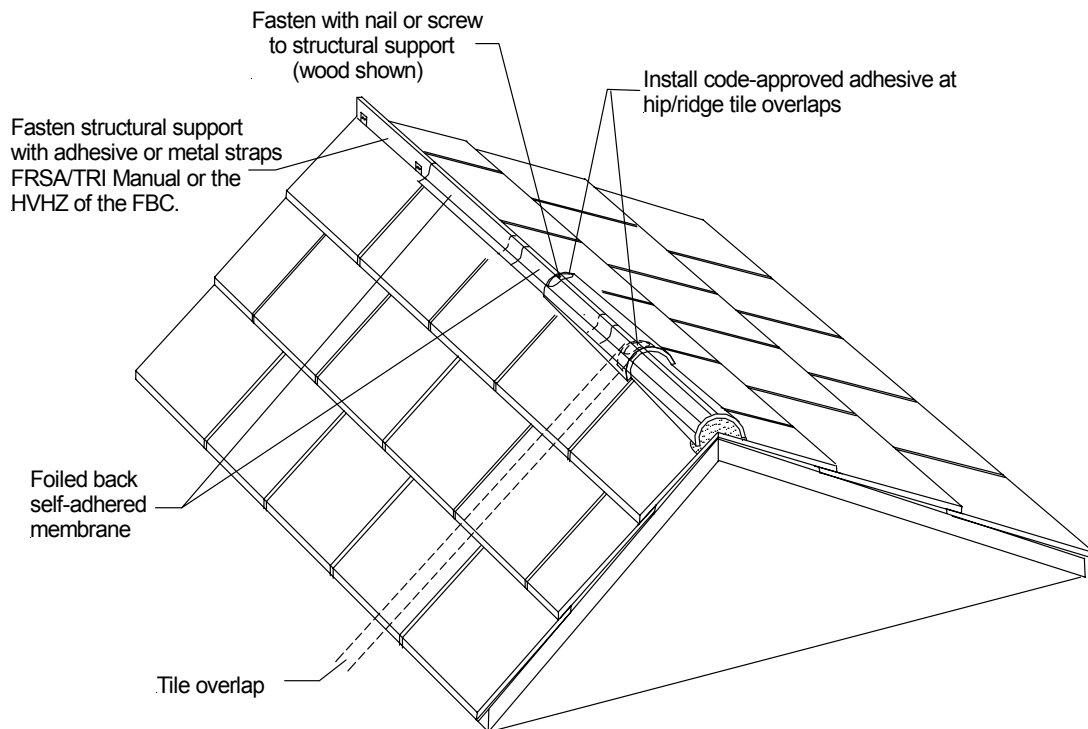

Foil-faced Self-adhered Membrane Used as a Weather Block

5.2.3 Adhesive Used as a Weather Block

5.2.3.1 This system uses adhesive as weather blocking system. There is no mortar placed along the longitudinal edges of the hip and ridge tile. Adhesive is placed where the field tile abuts to the structural support. A bead of adhesive is placed parallel to the hip and/or ridge board tile junction to act as a weather block and is applied prior to the attachment of the hip and ridge tile.

5.2.3.2 Install adhesive to seal all voids between the tile and the structural support according to the adhesive manufacturers recommendations. Care should be taken to ensure all areas are sealed with adhesive to prevent water entry.
(See Drawings 9 & 10)

Drawing 9

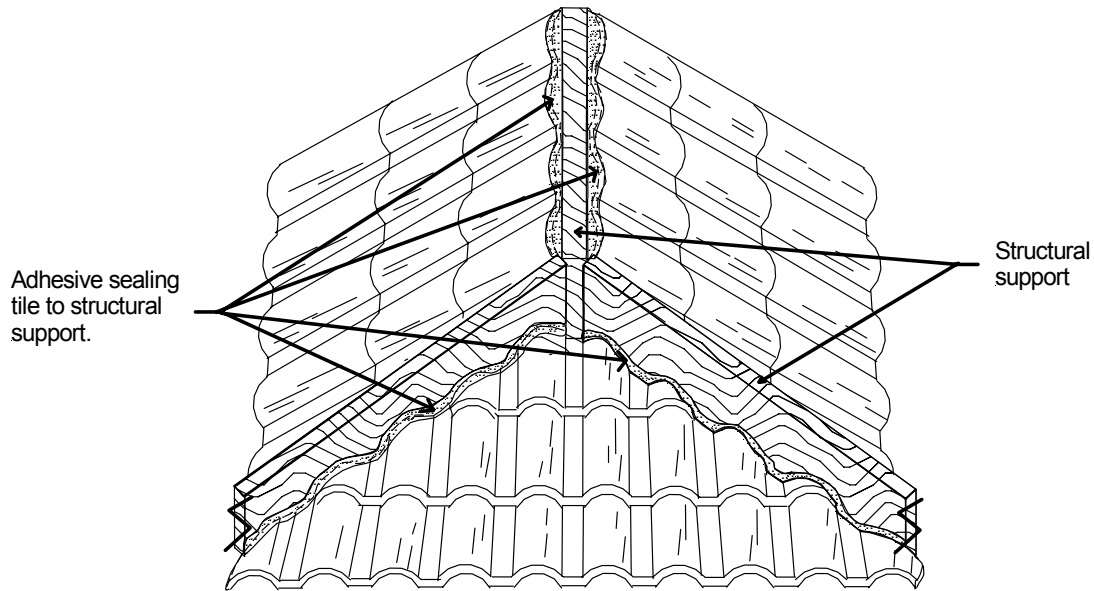

Adhesive used as weather blocking

Drawing 10

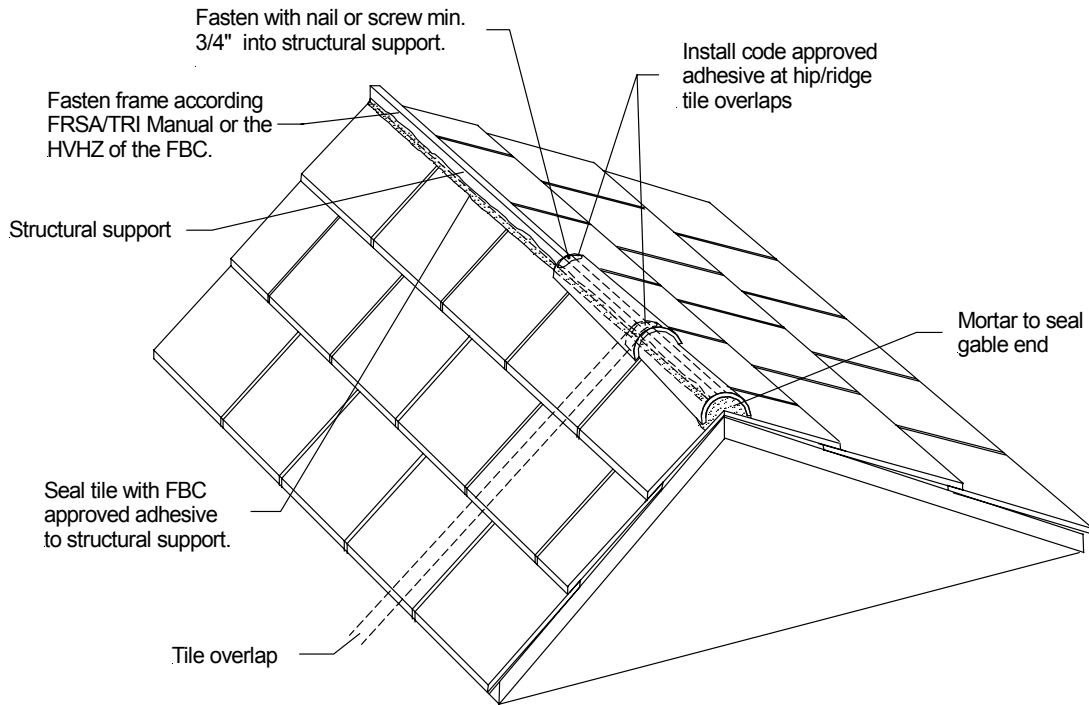

Hip/Ridge Tile Attachment Using Adhesive as Weather Block

Drawing 11

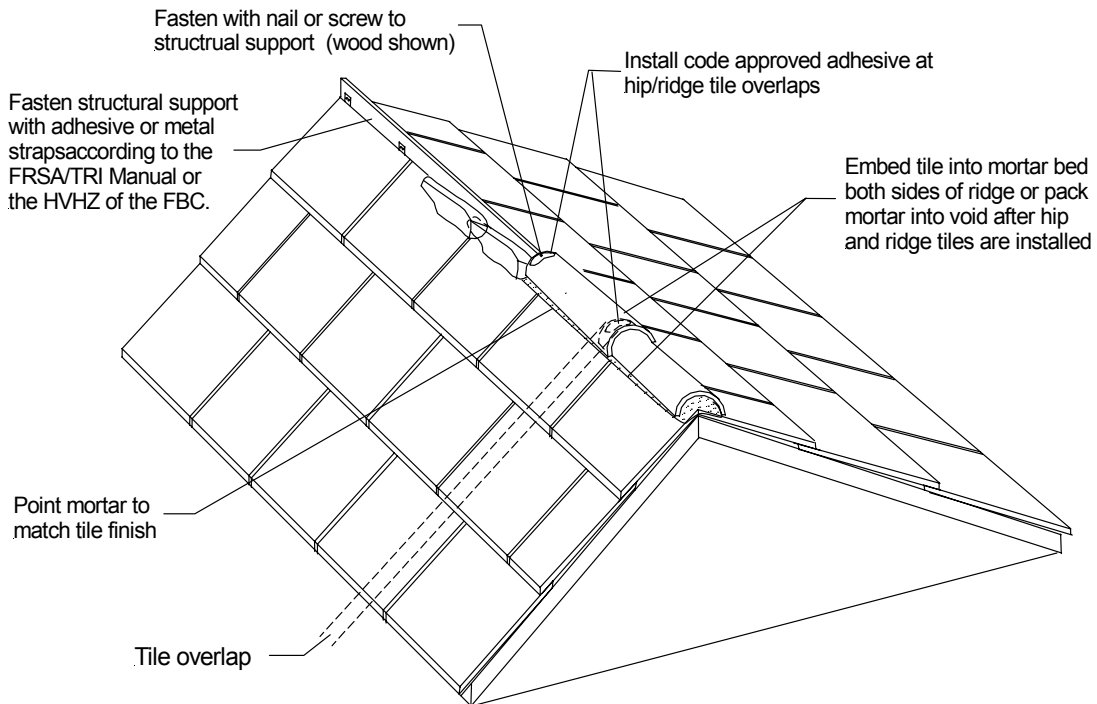

Attaching Hip/Ridge tile using Mortar as Weather Blocking

Drawing 12

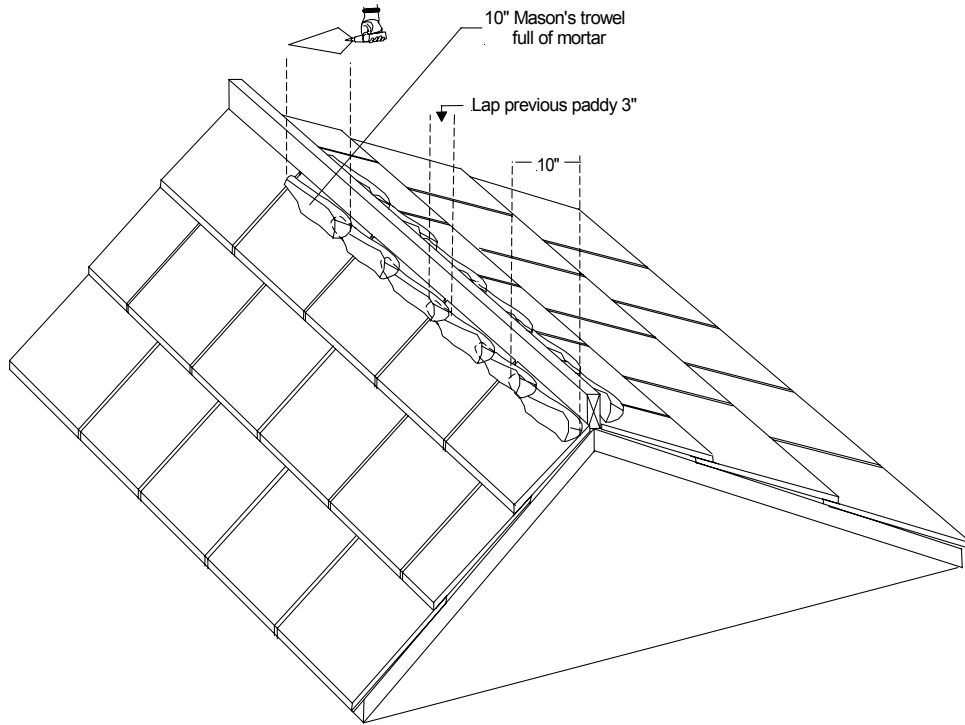

Mortar Hip and Ridge Weather Blocking System.

Drawing 13

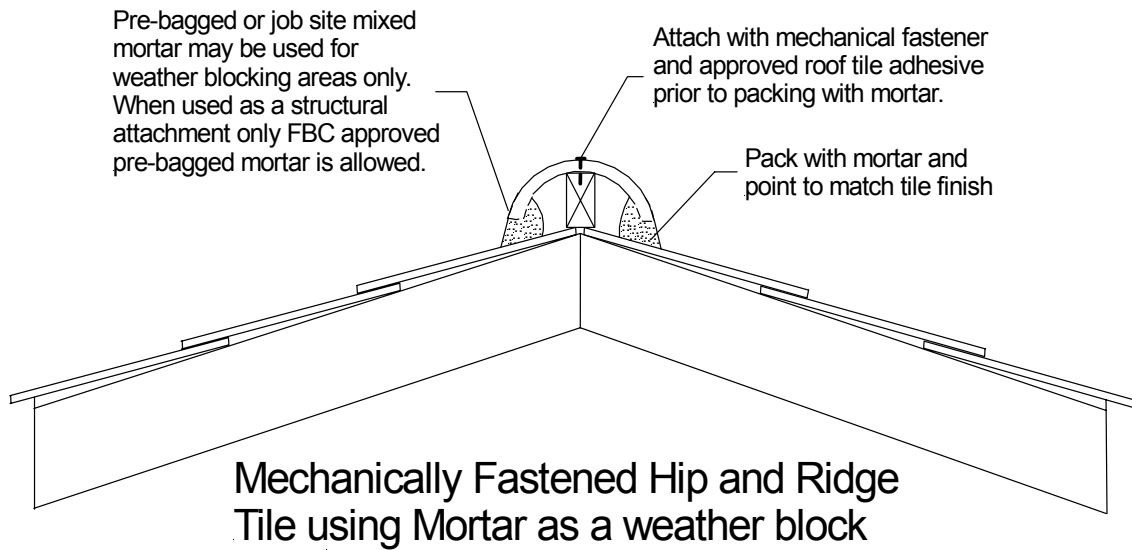

5.3. Hip and/or Ridge Starter Tile Attachment

- 5.3.1 Starting at the eave, place hip starter tile over wood hip frame, positioning in the center of the structural support. Secure the head of the starter tile to the structural support with a mechanical fastener conforming to the FRSA/TRI Concrete and Clay Roof Tile Installation Manual.
- 5.3.2 Care must be taken to properly secure the first (starting) hip and ridge tile of the hip/ridge attachment system. Additional securement at the hip starter tile installed at the eave and at the starting ridge tile installed at either the ridge/hip or ridge/gable junctions are necessary to prevent the tile from overturning during a high wind event.
- 5.3.3 Typically the structural support is kept 6” to 12” back from the eave to allow for the aesthetic placement of mortar used as a weather block and closing off the hip end at the eave. It may be necessary to extend or cantilever the structural support toward the eave to ensure adequate support for the hip tile attachment. **(See Drawing 25)** All hip or ridge starter tile must be secured at the both ends of the tile either with mechanical fasteners or adhesive. Although this section mentions hip starter tiles, the same is true for the starting ridge tile. Some options are listed below:
- 1) Drill a 3/16” hole within lower one-third of the tile length, from the eave end of the hip starter tile. Secure the eave end of the starter tile with a mechanical fastener embedding into the structural support, a minimum of ”. Seal the head of the fastener with a UV resistant sealant. Adhesive may also be used in lieu of a fastener at the starting end of the tile as long as the structural member has been cantilevered to provide a base for adhesive attachment.
 - 2) Prior to installing the hip starter tile, apply a code-approved roof tile adhesive along the entire length of the hip starter tile according to the adhesive manufacturers installation instructions. Secure the head of the tile with mechanical fastener embedding into structural support, a minimum of ”.
 - 3) Prior to installing the hip starter tile, place a full bed of **only FBC code-approved pre-bagged mortar** according to the mortar manufacturers installations instructions under the entire hip starter tile. Within 2 minutes of placing the bed of mortar, embed the entire hip starter into the solid bed of mortar. Secure the head of the tile with mechanical fastener embedding into structural support, a minimum of ”. Point mortar to desired finish. **When using this mortar method for securing the starter hip tile, ensure underlayment is approved for use with mortar-set applications.**

5.4 Hip and Ridge Tiles Mechanically Attached to Structural Support

- 5.4.1 Prior to installing subsequent hip/ridge tiles place a minimum 4” to 5” bead of FBC approved roof tile adhesive along the head of the hip starter tile. Install the next hip tile, centering over the wood frame and lapping the starter tile a minimum of 2”. **(See Drawing 8)**. If the overlap is restricted by product design, refer to the tile manufacturers installation instructions. Continue in same manner working from the lowest point toward the highest point of the roof. At intersecting junctions (i.e. hip/ridge, ridge/gable, ridge/valley) cut tile to form a solid fit and ensure the first and the last hip/ridge tile is securely fastened. Any exposed fasteners must be sealed with a UV resistant sealant.
- 5.4.2 Optional: Prior to installing the tiles at these adjoining junctions, place a full bed (filling entire cavity) of FBC approved pre-bagged mortar under the entire adjoining hip/ridge tile. Embed the entire hip/ridge tile into the solid bed of mortar. Point mortar to desired finish. Fasten as mentioned above. Use the three methods under Note ⁵ above as guidelines and/or options at these junctions.

6.0 Adhesive-set Hip and Ridge Attachment System

6.1. Adhesive-set Hip and Ridge Attachment System – Structural Support Options

- 6.1.1 Adhesive-set hip and ridge tiles can be installed directly to a structural support. The most common structural supports are:
- 1) Wood Hip and Ridge Frame **(See Drawings 4, 5, & 6)**
 - 2) Metal Hip and Ridge Frame (Metal Channel) **(See Drawing 14)**
- 6.1.2. Determine how you want to attach the wood hip and ridge frame to the substrate. The three most common methods to attach the wood hip and ridge frame to the substrate are:
- 1) Metal Brackets – **(See Drawing 4)**
 - 2) Metal Straps – **(See Drawing 5)**
 - 3) FBC approved Adhesive – **(See Drawings 15 & 17)**
- 6.1.3. Attachment of the wood or metal hip and ridge frame to the substrate must be according to Table 11 of the FRSA/TRI Concrete and Clay Roof Tile Installation Manual or according to the HVHZ requirements of the FBC. **(See Appendix A for a copy of the FRSA/TRI Table 11)**.

Drawing 14

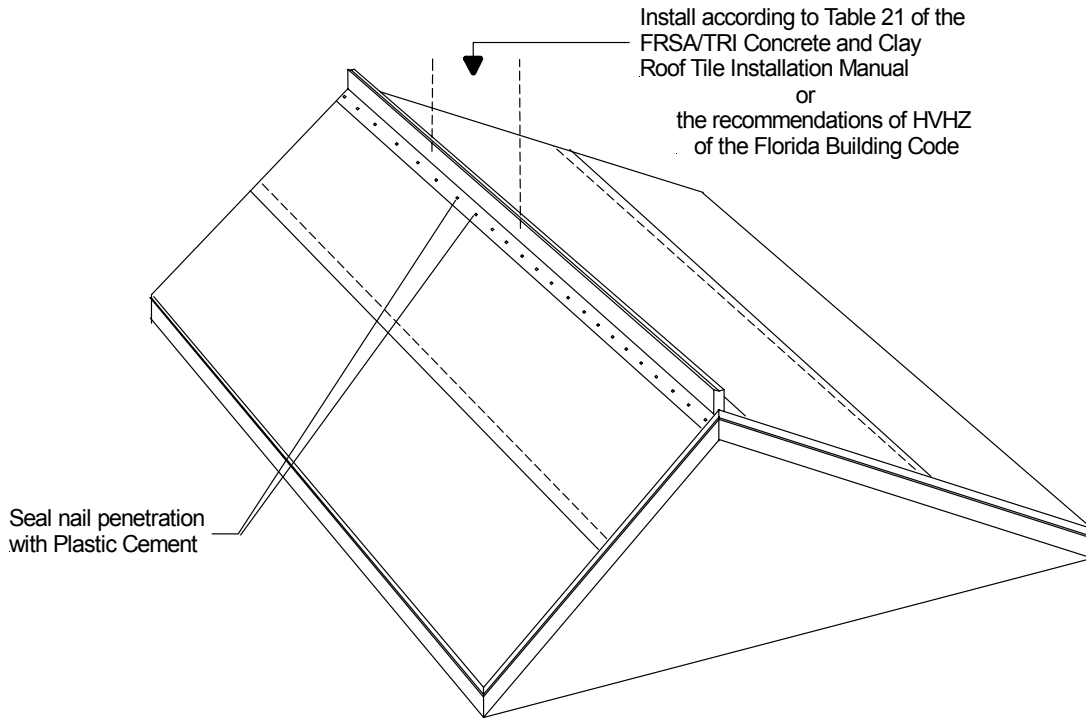

Metal Hip and Ridge Frame

6.2 Adhesive Weather Blocking System Options

6.2.1 Once the attachment method has been completed a choice has to be made on the weather blocking method. The two most common methods are:

- 1) FBC Approved Adhesive Tested as a Weather Blocking System –
(See Drawings 15 and 17)
- 2) (Pre-bagged or Jobsite Mix) Mortar Weather Blocking System –
(See Drawings 11,12 and 13)

6.2.2. Adhesive Used as a Weather Block

6.2.2.1. This system uses adhesive as weather blocking system. There is no mortar placed along the longitudinal edges of the hip and ridge tile. Adhesive is placed where the field tile abuts to the structural support. A bead of adhesive is placed parallel to the hip and/or ridge board tile junction to act as a weather block and is applied prior to the attachment of the hip and ridge tile.

6.2.2.2. Install adhesive to seal all voids between the field tile and the structural support according to the adhesive manufacturers recommendations. Care should be taken to ensure all areas are sealed with adhesive to prevent water entry.
(See Drawing 15)

Drawing 15

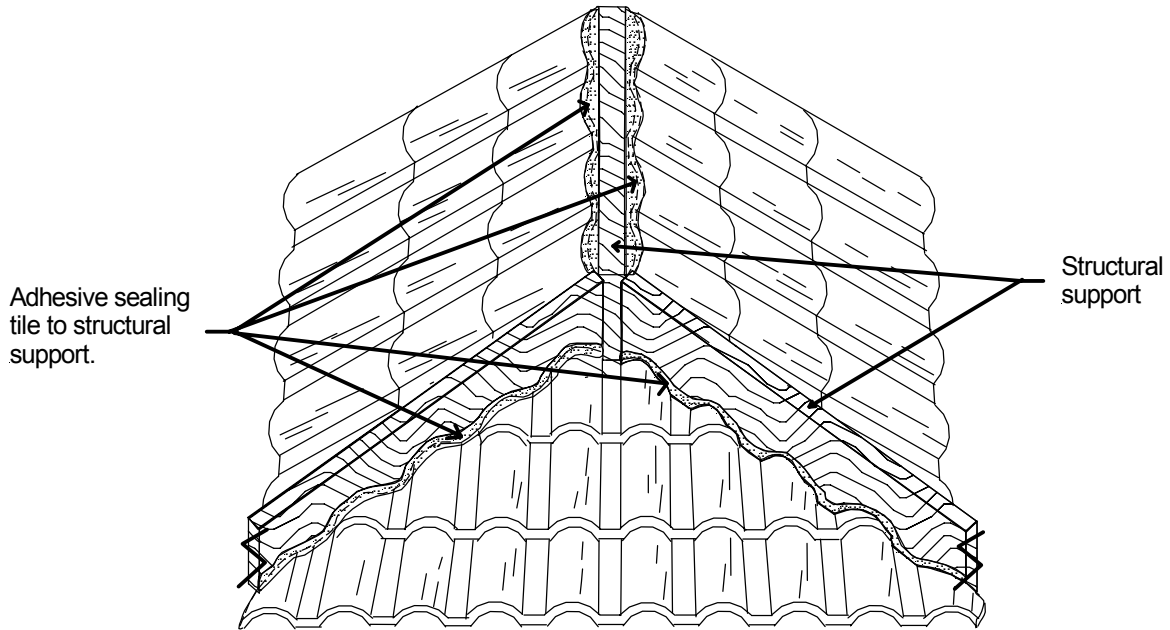

Adhesive used as weather blocking

6.2.3 Mortar Used as a Weather Block

6.2.3.1 This system uses mortar as weather blocking system and for aesthetics. A full bed of mortar is placed along the longitudinal edges of the hip and ridge tile either during the application of the hip and ridge tiles or may be packed in after the hip and ridge tiles are installed and the adhesive has cured. The hip and ridge tiles are adhesive-set to the structural support in addition to the mortar.

6.2.3.2 Install mortar to seal all voids between the field tile and the hip/ridge tile according to the mortar manufacturers recommendations. Care should be taken to ensure enough mortar is used, to create a wedge, to eliminate the potential of the mortar from dislodging from the hip/ridge and field tile junction. Ensure areas are sealed to prevent water entry. After mortar is packed into place point mortar to desired finish. (See Drawings 11, 12 & 13)

6.3. Adhesive-set Hip and Ridge Starter Tile Attachment

- 6.3.1 Starting at the eave, and prior to installing the hip starter, place a bead or paddy of FBC approved roof tile adhesive parallel to and on top of the wood or metal frame according to the adhesive manufacturer's instructions. An alternate method is to place the adhesive in the center of the underside of the hip/ridge tile, turn hip/ridge tile over and carefully place and center the tile over the structural support. The method of the paddy placement location must be representative of how the adhesive manufacturer tested the hip and ridge attachment method.
- 6.3.2 At the eave, place first hip (starter) tile over the metal or wood hip frame, positioning the tile in the center of the frame. Install the hip starter tile over the adhesive paddy or bead. Fasten hip tiles when the roof slope is greater than 7:12. The fasteners hold the tiles in place until the adhesive can cure.
- 6.3.3 Optional: Prior to installing subsequent hip tiles, Place a minimum 4" bead of code-approved roof tile adhesive along the head of the hip starter tile.

6.4 Adhesive-set Hip and Ridge Tile Attachment

- 6.4.1 Install the next hip tile, centering over the frame and lapping the starter tile a minimum of 2". **(See Drawings 16, 17 & 18)**. If the overlap is restricted by product design, refer to the tile manufacturers installation instructions. Continue in same manner working from the lowest point toward the highest point of the roof. At intersecting junctions (i.e. hip/ridge, ridge/gable, ridge/valley) cut tile to form a solid fit and ensure the first and the last hip/ridge tile is securely fastened. Any exposed fasteners must be sealed with a UV resistant sealant.
- 6.4.2 Optional: Prior to installing the tiles at these adjoining junctions, **place a full bed (filling entire cavity) of FBC approved pre-bagged mortar** under the entire adjoining hip/ridge tile. Embed the entire hip/ridge tile into the solid bed of mortar. Point mortar to desired finish. Fasten as mentioned above. Use the three methods under section 5.3.3 above as guidelines and/or options at these junctions.

Drawing 16

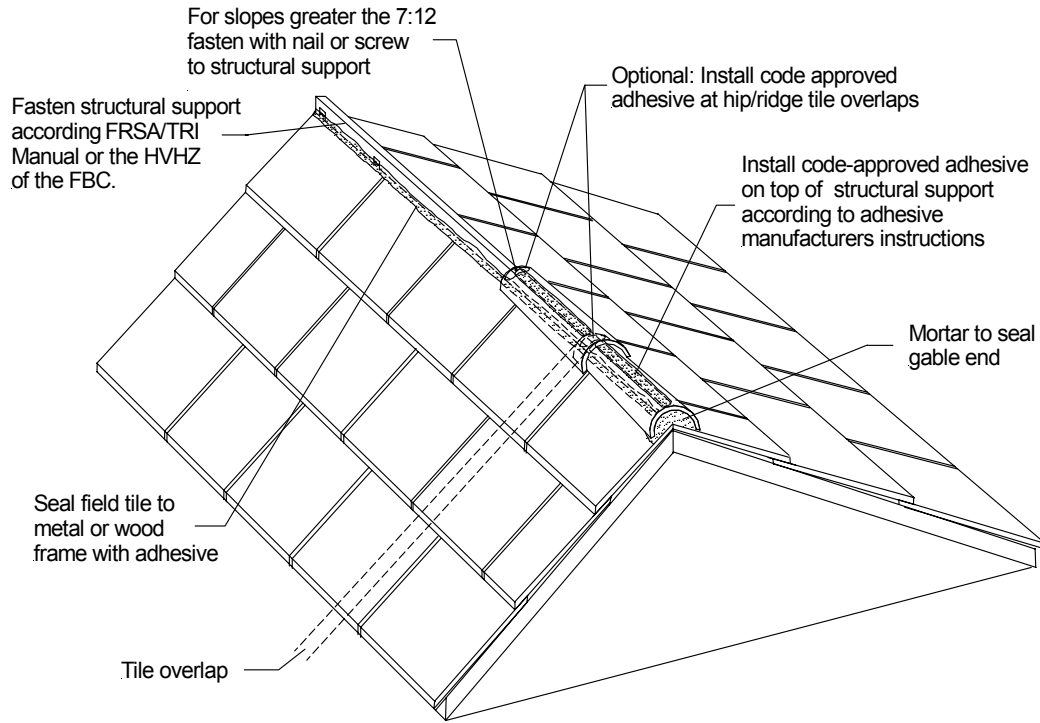

Adhesive-set Hip/Ridge Tile Using Adhesive as Weather Blocking

Drawing 17

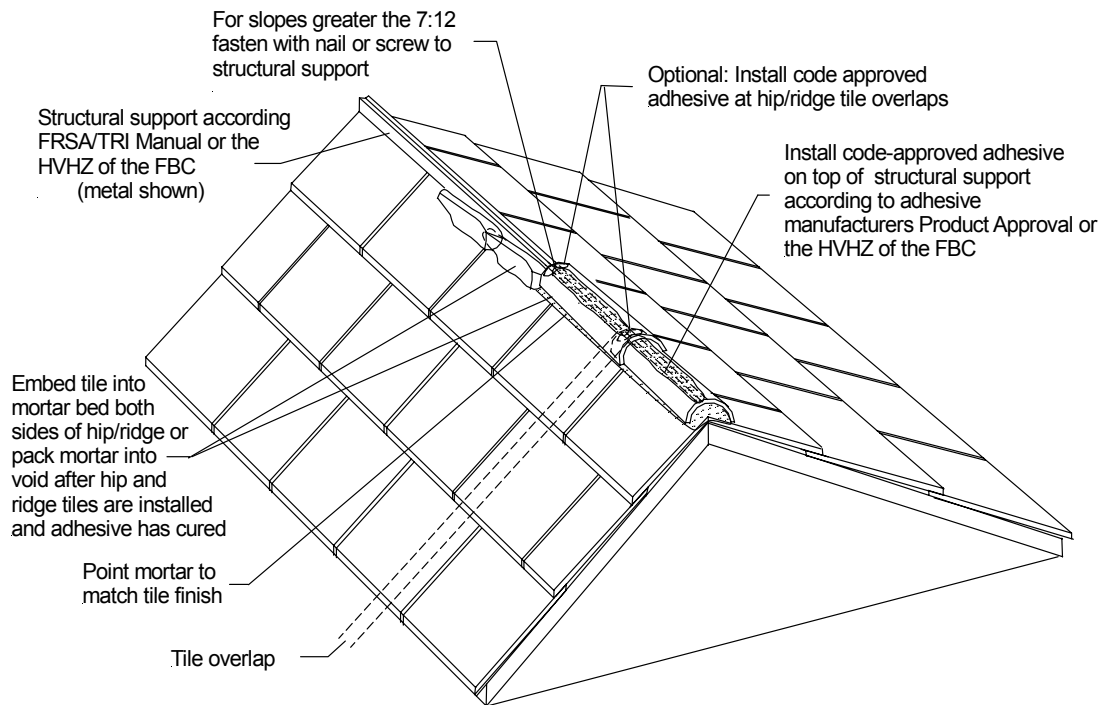

Attaching Hip/Ridge Tile with Adhesive Using Mortar as Weather Blocking

Drawing 18

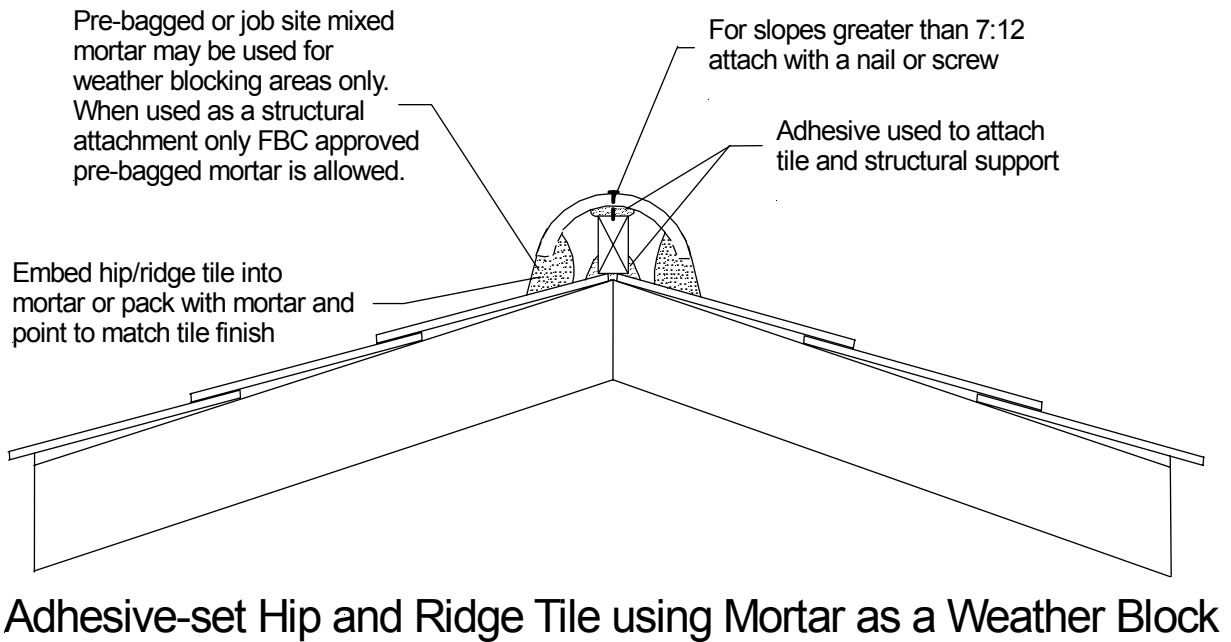

7. Mortar-set Hip and Ridge Tile Attachment System

7.1. Mortar-set Hip and Ridge Tile Attachment limitations

7.1.1 Mortar-set Hip and Ridge Tile Attachment System can only be used with field tile attachment Systems Three and Four 'B' and can only be installed with pre-bagged FBC approved (specifically according to Rule 9B-72) mortar tested to determine the limitations of the product application.

7.2. Mortar-set Hip and Ridge Starter Tile Attachment

7.2.1 Prior to installing any hip/ridge tile, a full solid bed of mortar is placed at the eave end of the hip or ridge starter tile and parallel to the hip and/or ridge structural support under where the longitudinal edge of the hip/ridge tile is to be placed. **(See Drawings 19, 20, 21, 22, 23 & 24) For Medium, High or Two-piece Barrel profiled tiles, it will be necessary to stack 10" trowel full of mortar on top of each other in the pan portions of the tile, to get the proper height of the mortar to properly embed the hip/ridge tile 1" into the mortar bed. (See Drawing 22)**

Drawing 19

Stack an additional trowel(s) full of mortar in the pan portion of the tile, as needed, to get the proper height of mortar to properly embed the hip/ridge tile 1 1/2" into the mortar bed.

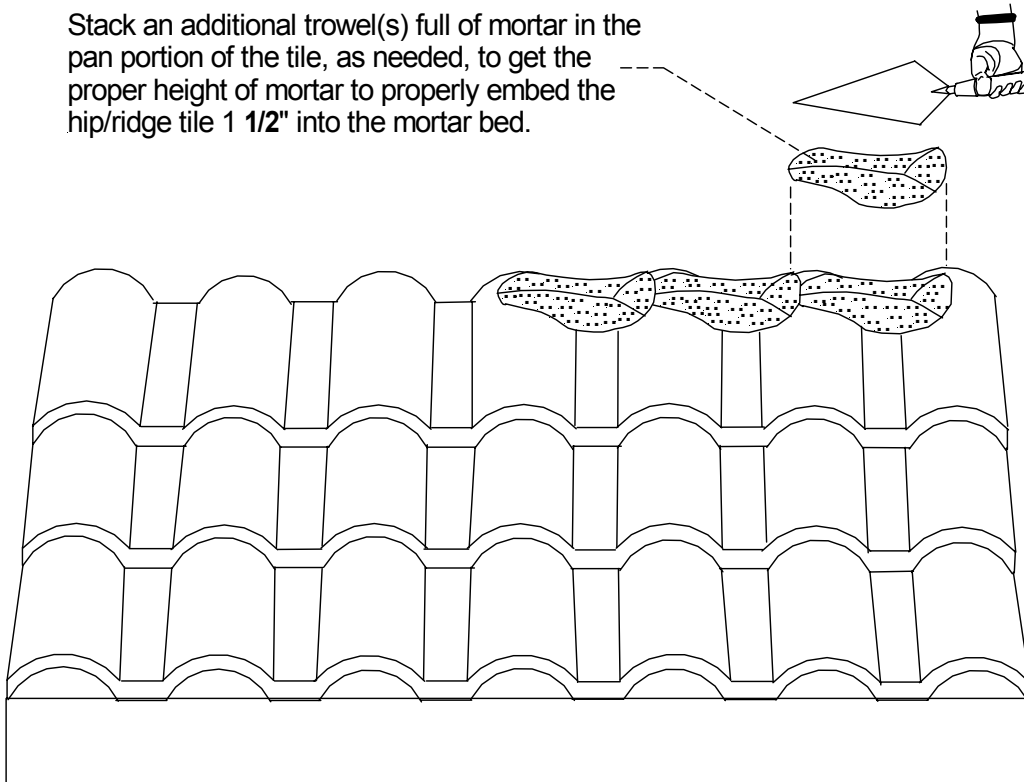

Proper Height of Mortar Bed

- 7.2.2. Apply enough FBC approved mortar to fill the entire hip/ridge starter tile cavity with mortar. Apply the remaining hip/ridge tile per mortar manufacturer's instructions. Care should be made to minimize the placing of mortar too far in front of laying tile to minimize mortar dehydration.
- 7.2.3. Position hip starter tile over the center of the hip junction. Embed the hip starter tile into the full bed of mortar. Some mortar will be forced out of the cavity. Remove excess mortar and point to desired finish.
- 7.2.4. Care must be taken to embed the tile into the mortar a minimum of 1 1/2". (Do not just fill the voids of the tile edges with mortar). The packing of mortar into the cavities between the hip/ridge tiles and the field tile are not allow for the structural attachment of the hip and ridge tiles. The tile must be embedded into the mortar.

Drawing 20

Use only FBC approved mortar that has been tested according to ICC - SSTD-11 and has data substantiating compliance.

For the starter hip or ridge tile fill entire cavity with mortar

Point to match tile finish

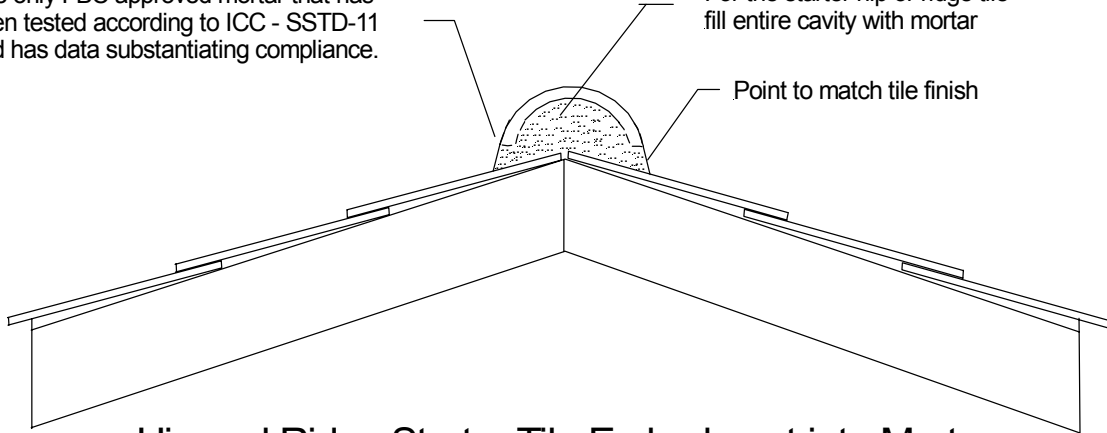

Hip and Ridge Starter Tile Embedment into Mortar

7.3 Mortar-set Hip and Ridge Tile Attachment

- 7.3.1 Position and install the next hip tile, centering over the hip junction and lapping the starter tile a minimum of 2". Embed the tile into the mortar bed a minimum of 1". **(See Drawing 22)**. If the overlap is restricted by product design, refer to the tile manufacturers installation instructions. Continue in same manner working from the lowest point toward the highest point of the roof. At intersecting junctions (i.e. hip/ridge, ridge/gable, ridge/valley) cut tile to form a solid fit and ensure the first and the last hip/ridge tile is securely fastened. Any exposed fasteners must be sealed with a UV resistant sealant.
- 7.3.2 At all junctions (i.e. hip/ridge, ridge/gable, ridge/valley etc.) fill all voids with mortar. Prior to installing the junction tiles a bed of mortar must be placed to minimize any cracking of the mortar. These cut or mitered tile must be embedded into the mortar. Point mortar to desired finish.
- 7.3.3 Optional: The entire cavity of the hip and ridge tile may be filled a bed of mortar in lieu of longitudinal beads placed parallel to the hip and ridge junction. **(See Drawing 20)**

Drawing 21

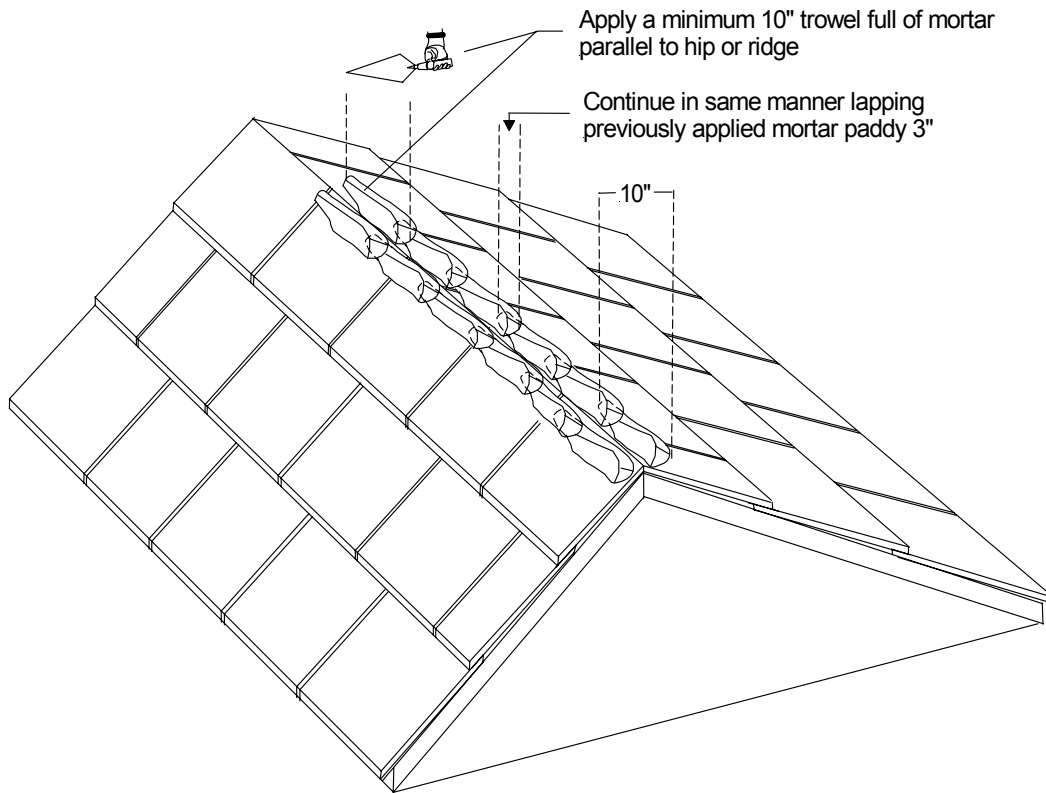

Mortar-set Hip and Ridge Attachment

Drawing 22

Use only FBC approved pre-bagged mortar that has been tested according to ICC - SSTD-11 and has data substantiating compliance.

Embed hip/ridge minimum 1 1/2" into 3" bed of mortar prior to pointing up mortar for a finished appearance. Do not pack mortar into cavity.

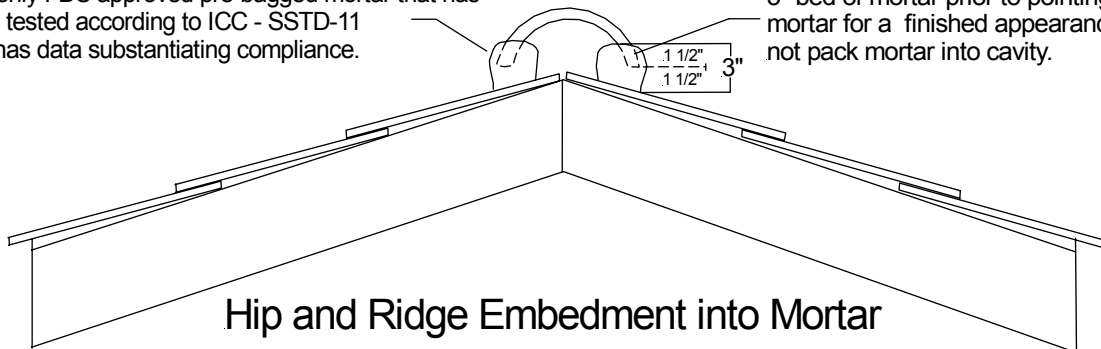

Drawing 23

Use only FBC approved pre-bagged mortar tested according to ICC - SSTD-11 with data substantiating compliance.

Point to mortar to desired finish

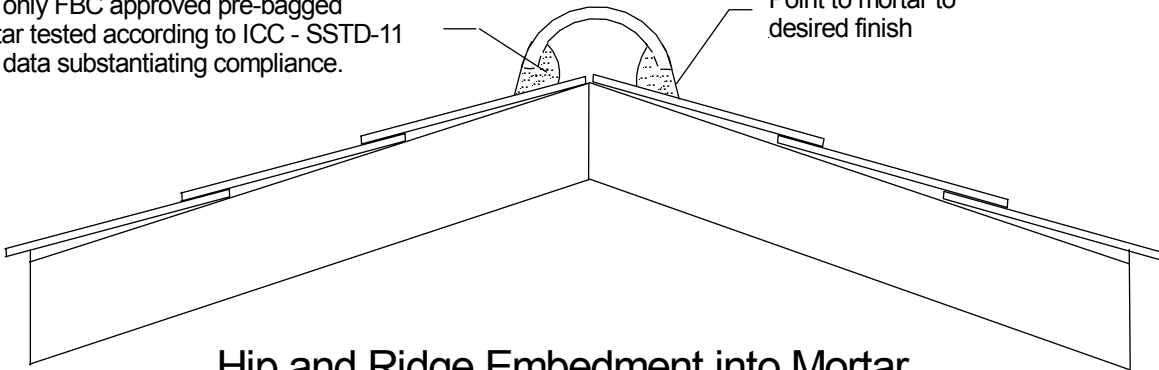

Hip and Ridge Embedment into Mortar

Drawing 24

Full bed of FBC approved pre-bagged mortar

Embed tile minimum a 1 1/2" into mortar bed

Point mortar to desired finish

Tile overlap

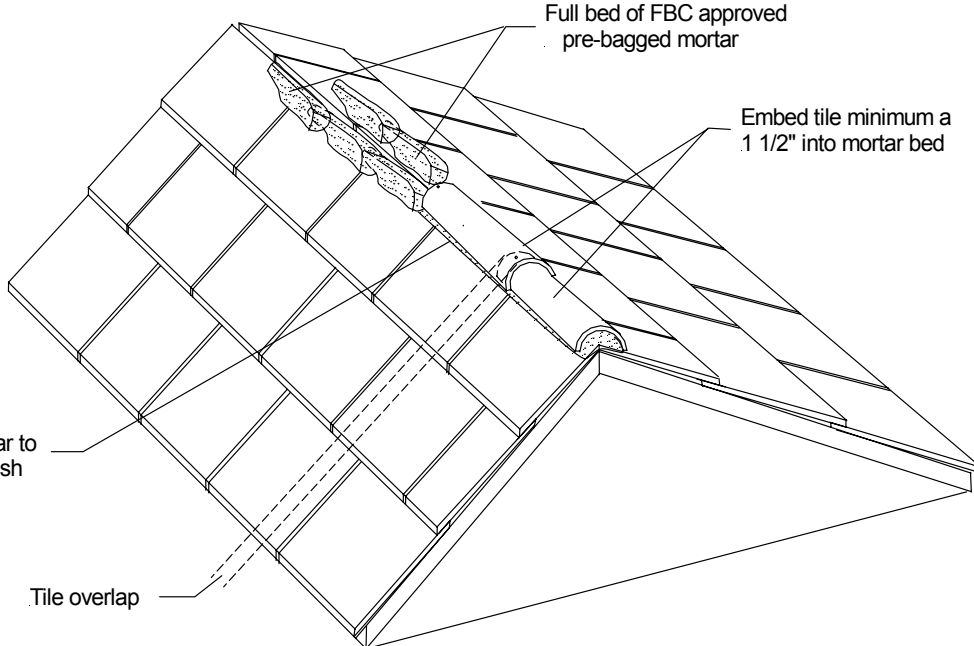

Attaching Hip/Ridge Tile with FBC Product Approved Mortar Only

Drawing 25

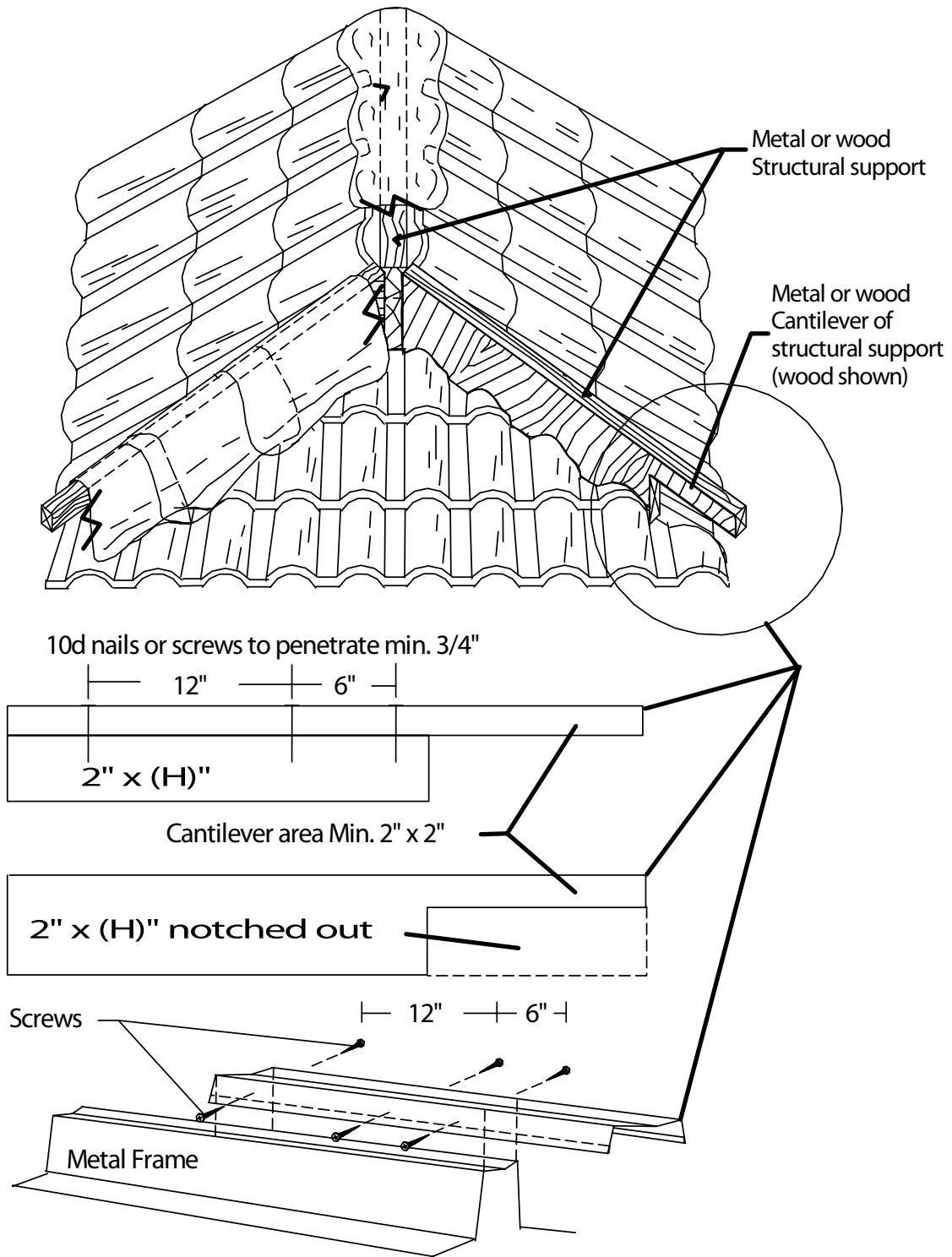

Hip End Cantilever Options

Hip and Ridge Support Member Attachment Recommendations

How to use Table 11:

1. Determine the Exposure Category (See Page 105).
2. Determine the thickness of the roof sheathing.
3. Determine the basic wind speed.
4. Follow the rows to the right, based on the information gathered from steps 1 through 3 above. Under the appropriate basic wind speed column, lists the center-to-center spacing based on either a 3/4” strap using 1 screw or an 1 1/2” strap using 2 screws.

Table 11

Category II Buildings

Hip and Ridge Support Member Attachment Recommendations

Roof Sheathing (inches)	Exposure	Number of Fasteners on each side of Ridge Board	Strap Width	Basic Wind Speeds, V (mph)					
				100	110	120	130	140	150
				Center to Center Spacing (inches)					
15/32"	B	1 - #8	3/4"	36	29	25	21	18	16
		2 - #8	1-1/2"	48	48	43	36	31	27
	C	1 - #8	3/4"	27	22	18	16	13	12
		2 - #8	1-1/2"	46	38	32	27	23	20
19/32"	B	1 - #8	3/4"	38	32	24	22	19	17
		2 - #8	1-1/2"	48	48	43	36	31	27
	C	1 - #8	3/4"	29	24	20	17	14	12
		2 - #8	1-1/2"	46	38	32	27	23	20

Note¹: For Building Category Definition See Page 104.

Note²: For Exposure Categories See Page 105.

Note³: Table conforms to ASCE 7-02. Essential or Hazardous Facilities having an Importance Factor of 1.15

Note⁴: Table is good for Gable and Hip Roofs for Roof Slopes 2:12 < ? <= 12:12. Monoslope roof slopes are not addressed.

Note⁵: For mean roof heights over 60 feet, engineering calculations must be submitted for permitting.

Notes:

1. These measurements were based on actual center-to-center spacing.
2. Minimum thickness of roof sheathing shall be 15/32”.
3. Steel straps shall have a minimum tensile strength (F_u) for cold-rolled steel of 42 ksi and a minimum Design yield strength (f_y) for cold-rolled steel of 25 ksi conforming to one of the following ASTM A 606; ASTM A 607; ASTM A 611; ASTM A 653; ASTM A 715; and ASTM A 792.
4. Minimum thickness of steel straps shall be 26 gauge (0.0179”) before application of corrosion Resistance protection.
5. #8 wood screws are to conform to ASME / ANSI B18.6.1.
6. #8 wood screws shall have a minimum end distance, an edge distance, and a minimum distance between screws of 1/2”. The distance is to be measured to the center of the screw.
7. Table 11 is for Category II buildings with a mean roof height of 60’ or less.
8. The building is not located on isolated hills, ridges, or escarpments, constituting Abrupt changes in general topography, which creates wind speed-up effects.