



Submersible Wastewater Pump Association

An Introduction to Pressure Sewers

A Pressure Sewer is . . .

- A sanitary sewer system that utilizes a network of grinder pumps to transport wastewater through small diameter pipes to a collection and treatment system.
- A grinder pump is a submersible pump designed to reduce wastewater particulate to a slurry through the use of a grinding mechanism.

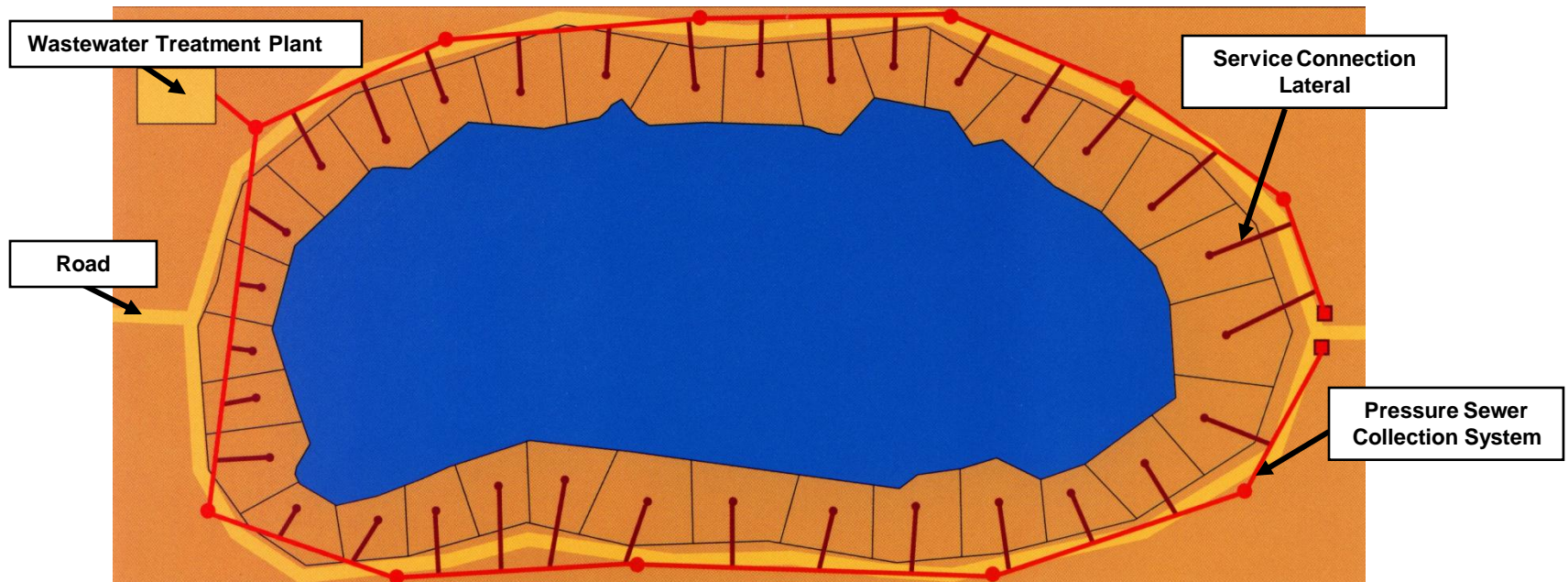

Typical lakefront pressure sewer system

How big is it?

- **Systems can be as small as a single station pumping into an existing gravity sewer line**
- **Systems can be as large as thousands of stations tied together with a piping network stretching for miles before discharging to a collection point**

Pressure Sewers are not limited by gravity

- Wastewater is pumped through small diameter pipes following the contour of the land, set in shallow trenches just below the frost line
- Lift stations are minimized or eliminated in virtually every installation
- Wastewater treatment plants for these systems are less costly to build since the system is closed to infiltration and solid sizes are minimized.



Pressure sewers do not require big equipment, major excavation and lift stations like gravity sewers



Overcoming obstacles

- **Directional boring can eliminate the need for trenches and install pipe under rivers and roadways**
- **Site restoration costs are minimized**



Pressure Sewers provide...

- An economical solution to geo-technically challenging environmental conditions where gravity sewers may be impractical if not impossible.
- *Examples include:*
 - Rocky soil
 - Hilly terrain
 - Shallow bedrock
 - High water tables
 - Long flat terrain
 - Slow growth areas
 - Existing structures and roads
 - Shallow bedrock



Pressure Sewers are economical

Prepackaged systems are available that:

- Lower up front costs by allowing developers to add grinder pump stations as new homes are built
- Allow developers to build in areas that are inaccessible to gravity sewers
- Minimize the need for manholes and lift stations, making more lots marketable for sale
- Lower cost per lot in low density development areas



Pressure Sewers: A Proven Technology

- **First used in the early 1970's**
- **Provide daily service to millions of users worldwide**
- **Have demonstrated excellent performance, high reliability and low Operating and Maintenance costs**



A compatible solution

- **Pressure sewer systems are compatible with other types of collection systems**
- **Pressure sewer systems can be integrated into existing collection systems**
- **Multiple systems can be blended into site specific designs to provide a complete solution to wastewater challenges**

Typical residential installation

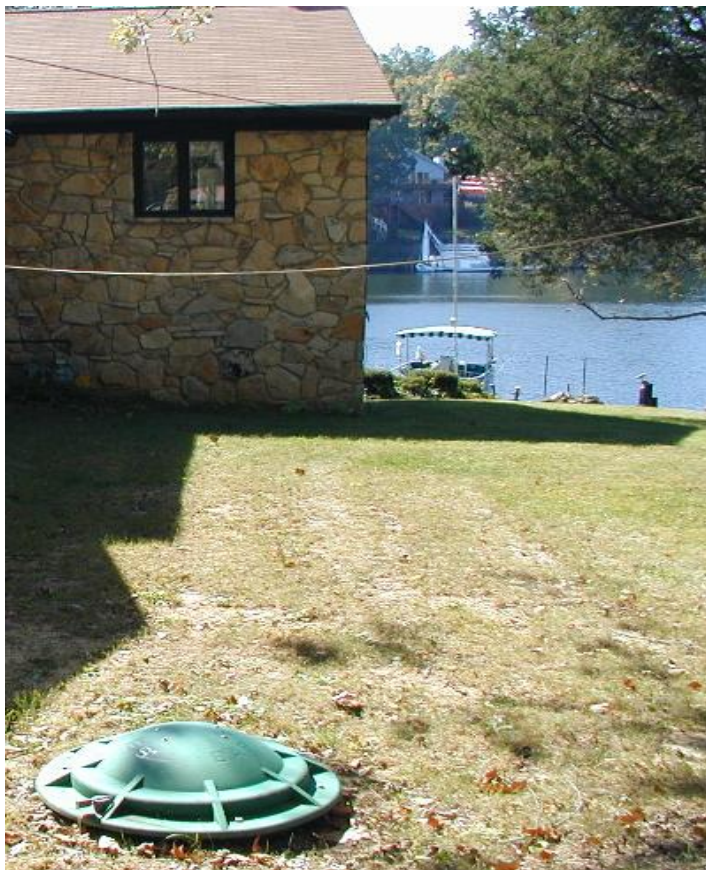

- A grinder pump station is located in the yard or basement of each home
- Wastewater flows into the station from the building's sewer line (typically 4")
- The basin contains a grinder pump, level sensors, valves and discharge piping

Typical residential installation

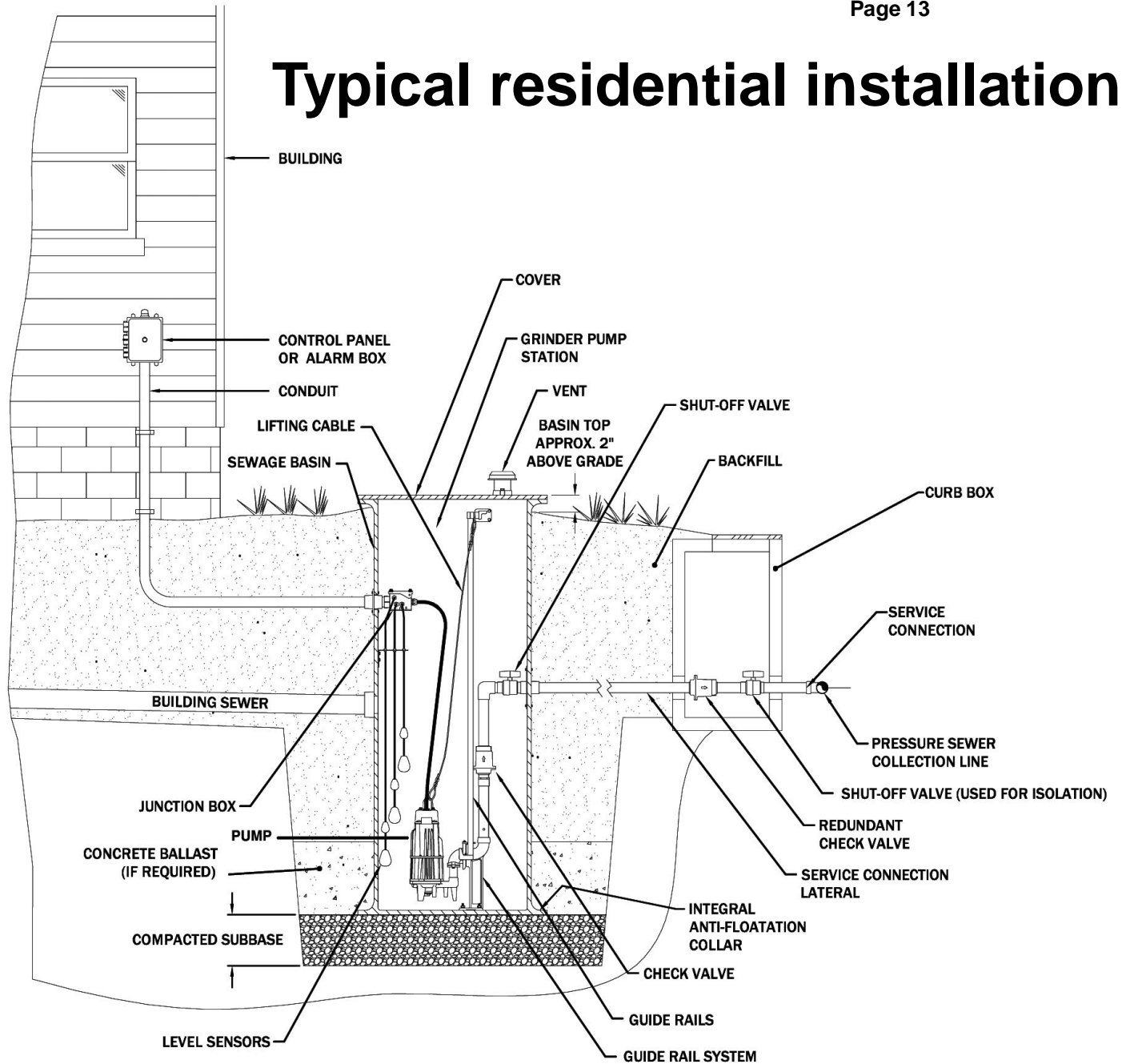

Typical residential Grinder Pump site components

- A pressure sewer collection line is laid along the edge of the roadway, following the contour of the land
- The pressure sewer collection line delivers the wastewater to a central treatment system, manhole, or force main
- Wastewater may be transported several thousand feet to a discharge point at a higher elevation

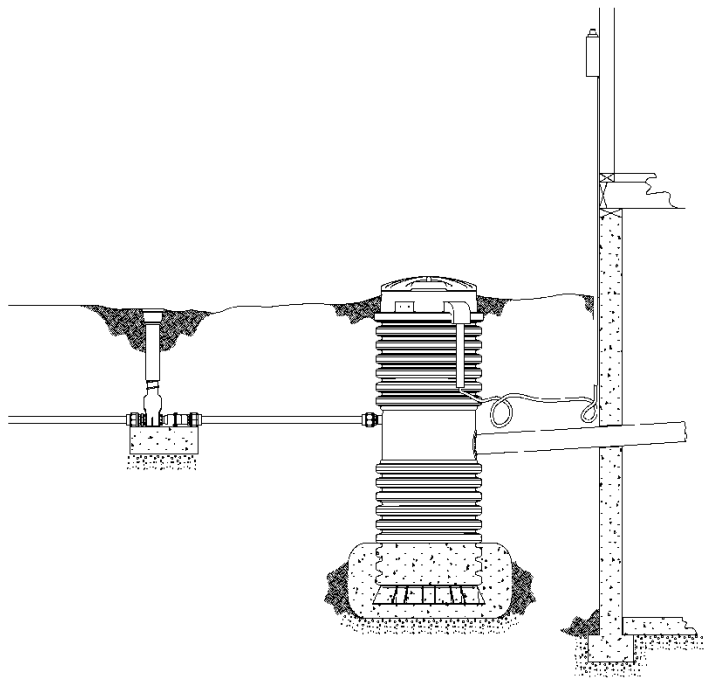

Residential Grinder Pump Packages - 2 styles

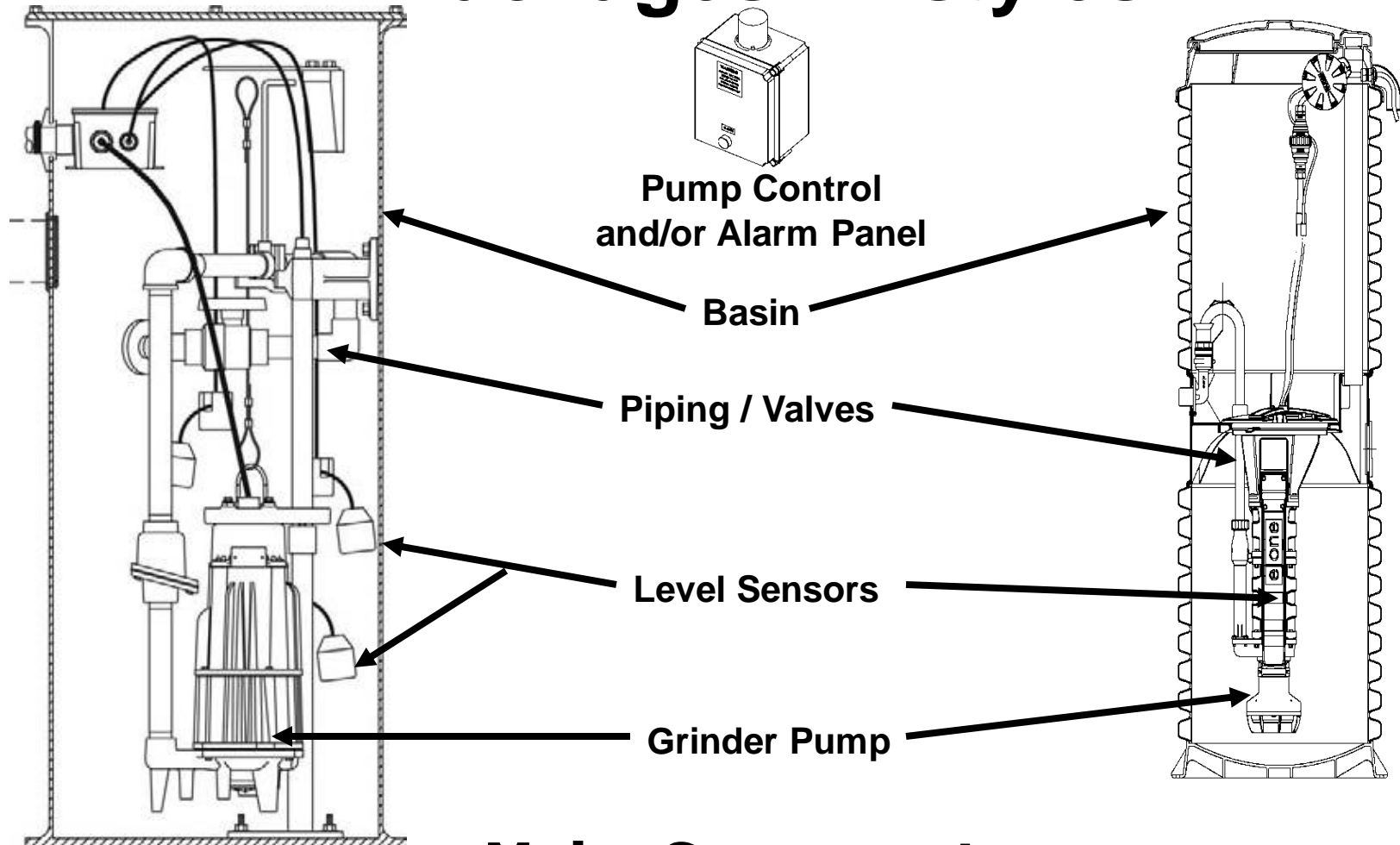

Major Components

Grinder Pump

- A submersible pump designed to reduce wastewater particulate to a slurry through the use of a grinding mechanism
- Typical Types
 - Progressing Cavity (1 - 2 HP)
 - Centrifugal (2 - 15 HP)
- Discharge Size - 1-1/4" to 3"

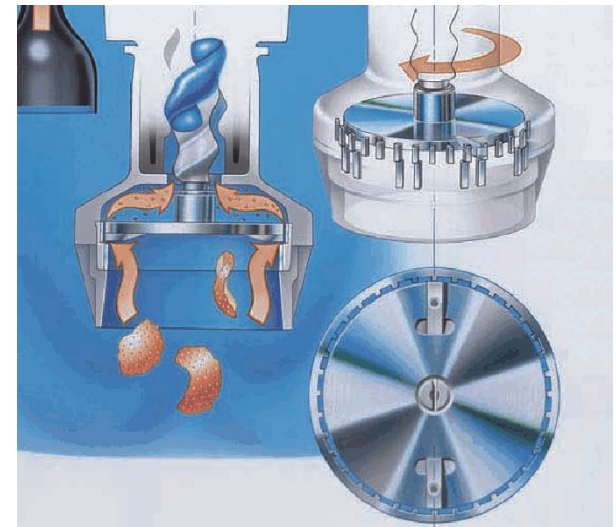

Pump hydraulics

- Typical residential performance curves

A – Centrifugal

B – Progressing Cavity

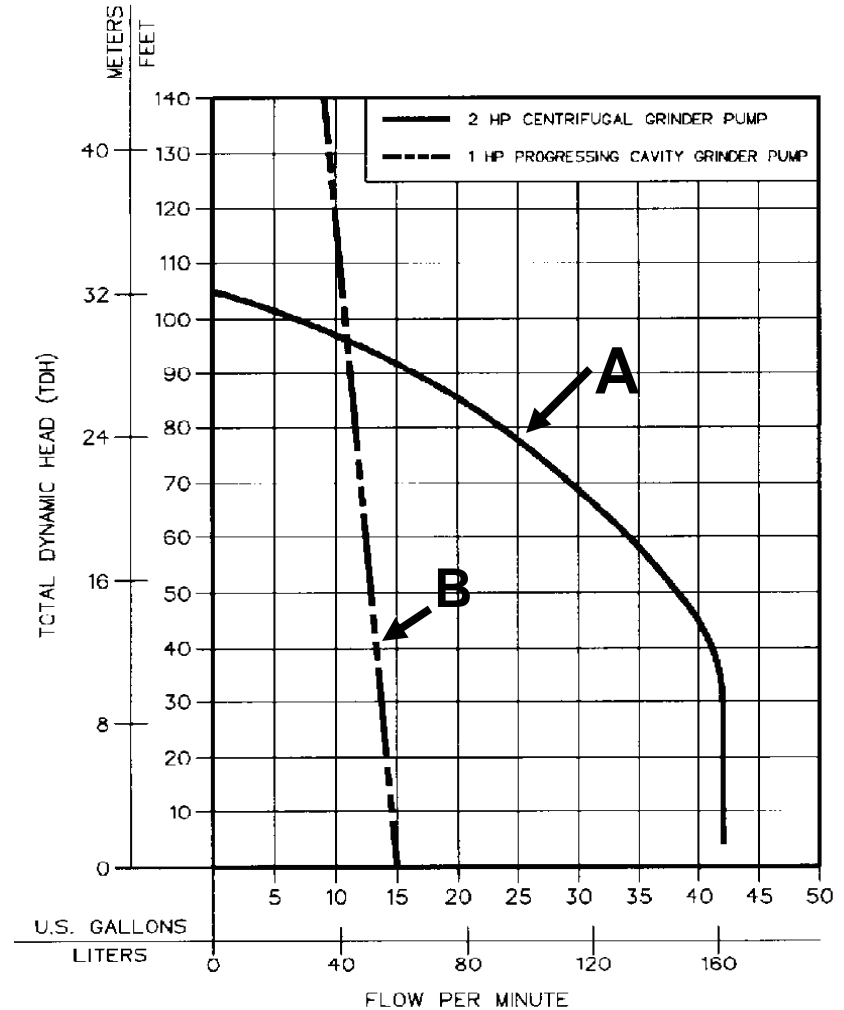

Basin

- The basin* is a watertight holding tank located below grade. High Density Polyethylene (HDPE) and fiberglass are the most common basin materials

- Basins are equipped with an anti-flotation collar, preventing them from floating out of position if the ground water table rises

** For additional information see the SWPA's Basin Reference Guide*



Pump control alarm panel

- A lockable, weatherproof enclosure
- Disconnect and circuit protection
- Motor contactor with optional overload protection
- Selector switches / Pilot lights
- High water alarm
- Thermal protection
- Pump, power, and float terminal blocks



Station operating sequence

- Wastewater flows from the house to the pump basin via gravity
- Once wastewater fills the basin to a predetermined point, the level sensor signals the pump to turn on
- The grinder pump grinds the wastewater into a slurry and pumps it out the small diameter pipeline to the collection system
- Once the wastewater level in the basin lowers to a predetermined point, the level sensor signals the pump to turn off

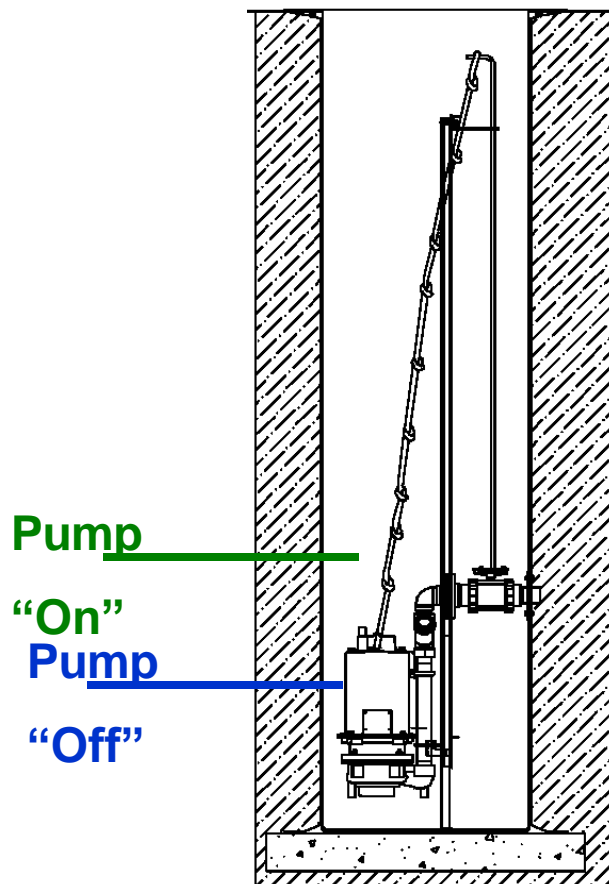

Station operating sequence

- If the pump does not operate when signaled by the wastewater level sensor the sewage level continues to rise, activating a high water alarm
- The high water alarm is normally an audible and/or visual alarm and may be a remotely monitored signal

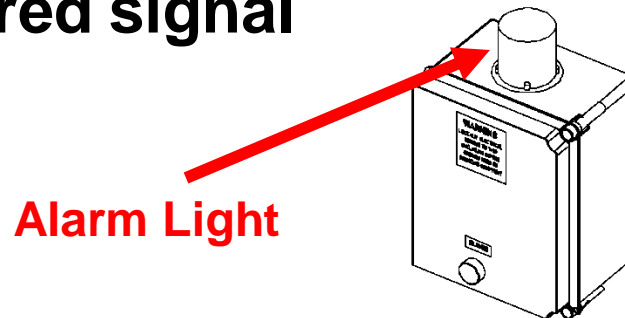
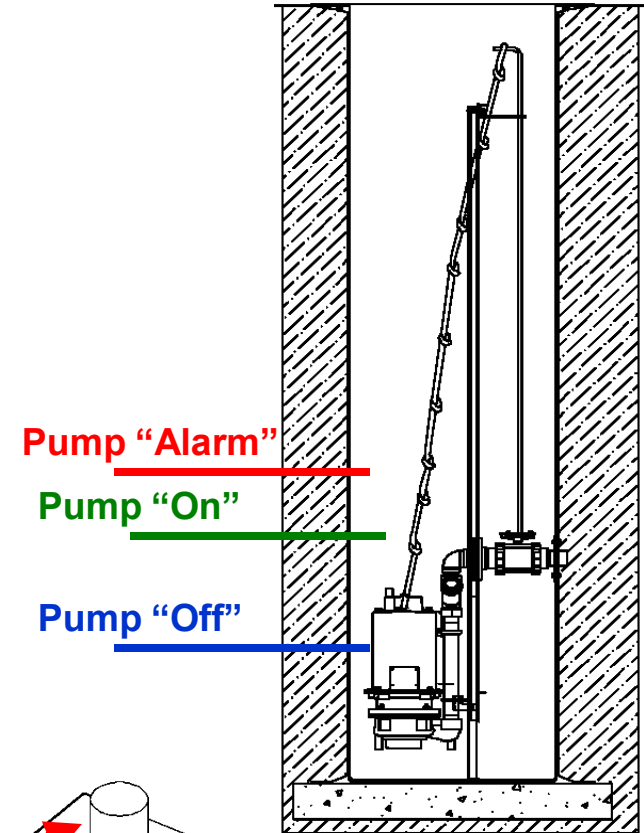

Typical commercial station

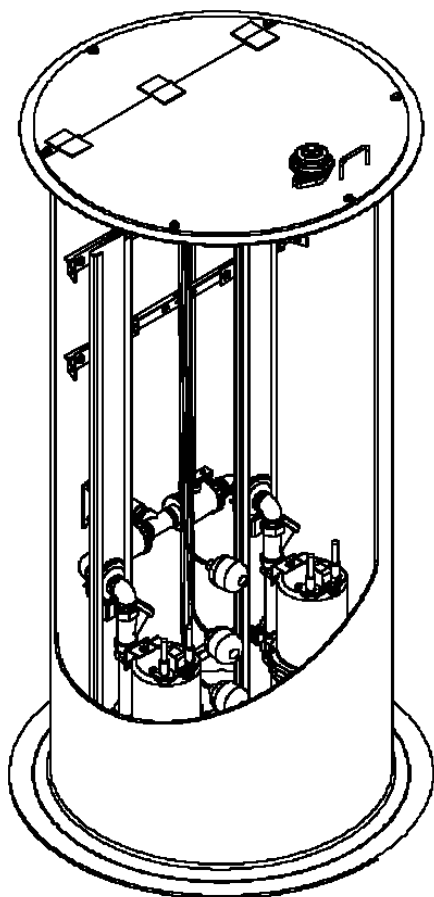

- Larger pump station basin for added storage capacity
- Two submersible grinder pumps to provide redundancy
- The control panel will include an alarm and an alternator to run each pump every other cycle

Caution: Code requirements may be more stringent for commercial stations than for residential stations.

Operating costs

- **Operating costs for a typical residential station can be less than \$3.00 per month***
- ** Based on 10 cents per Kilowatt Hour and 300 Gallons per day*



In Summary

Pressure Sewer Systems:

- **Lower infrastructure development costs**
- **Minimize environmental disruption and restoration costs**
- **Are a reliable and economic solution to geo-technically challenging environmental conditions**
- **Are economical to operate**
- **Provide daily service to millions of users worldwide**

Questions?



Additional Information

A Press Information Kit describing “*Grinder Pumps in Pressure Sewers*” is available in hard copy format upon request from SWPA Headquarters and is downloadable from the SWPA web site at www.swpa.org

“*Grinder Pumps in Pressure Sewers*”, is a 50-page SWPA Technical Resource (\$10.95 plus S&H). Visit the SWPA Web Site at www.swpa.org for a Technical Resources Order Form or call SWPA Headquarters.