

FASTENMASTER

TECHNICAL RESOURCES

- FrameFAST™ Wood Framing System 43
- TimberLOK® Heavy Duty Wood Screw 49
- HeadLOK® Heavy Duty Flathead Fastener 51
- LedgerLOK® Ledger Board Fastener 52
- FlatLOK® Structural Wood Screw 53
- ThruLOK® Through-Bolt Replacement 57
- Lateral Tension System® Code Compliant Lateral Deck Attachment 59
- Reference Charts 61

FrameFAST™

PRODUCT SPECIFICATION

Part Number: FMFF006

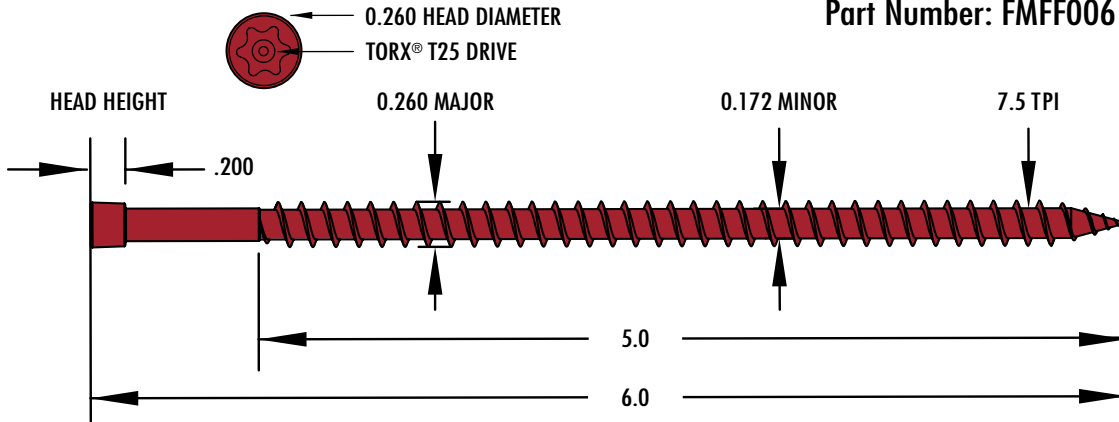

Continuous Load Path Connections

The FrameFAST offers a faster, easier solution when making critical connections between framing components designed to transfer loads between the roof, walls, and floors to the foundation. In many cases, a single fastener can replace straps or ties usually requiring multiple nails and time-consuming installation steps.

Using our FrameFAST tool, the screw can be easily driven at the appropriate angle, depth and location without the need for a ladder or pneumatic gun – increasing both safety and productivity.

The most popular connections are shown here and detailed on the following pages.

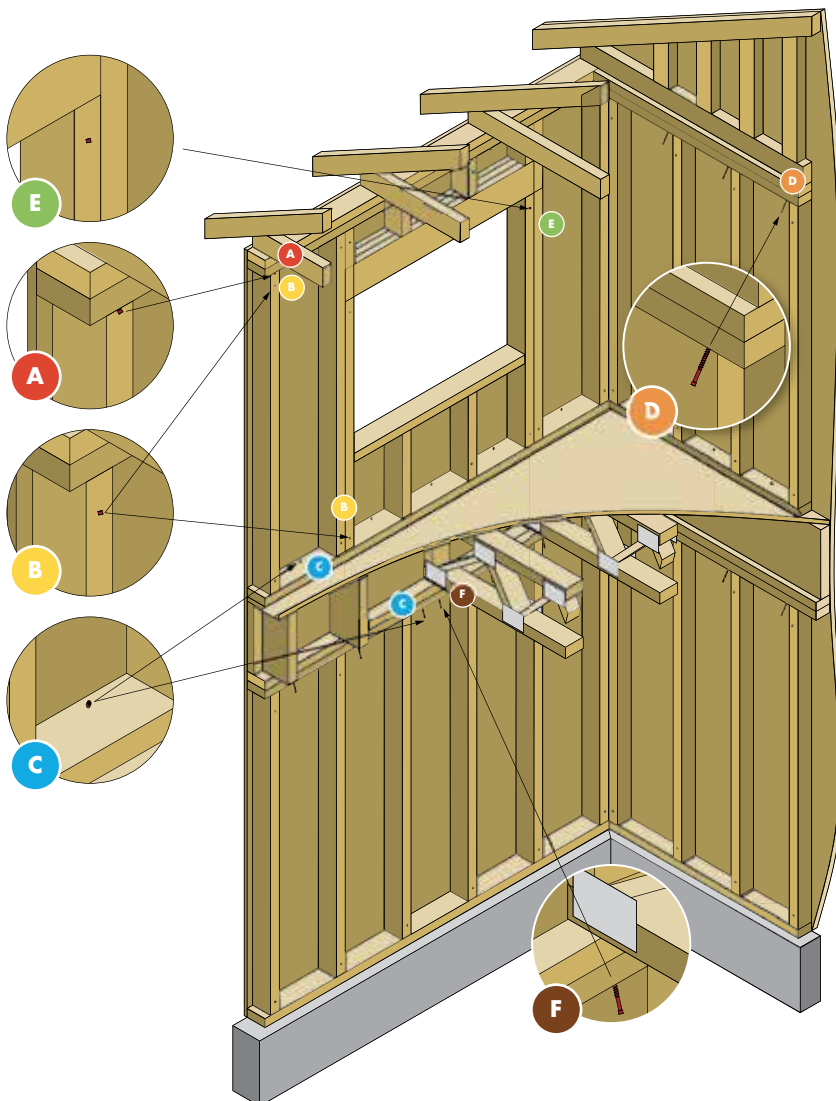

- A** Truss to Top Plate
- B** Stud to Top and Bottom Plate
- C** Top and Bottom Plate to Rim Board
- D** Gable or Drag Truss
- E** Jack Stud to Header
- F** Bottom Plate to Floor Truss

FRAMEFAST CONNECTIONS

A Truss to Top Plate

FrameFAST can be used as a direct replacement for the most common hurricane ties to resist uplift and lateral loads on trusses or rafters attached to the top plates of the wall. The fastener is installed at the prescribed angle through the top plates or header and into the center of the truss or rafter above, as shown in the detail below. The FrameFAST Tool, with its specifically designed head, can be used to ensure proper alignment and installation every time.

To verify the adequacy of this connection for your specific application, confirm that the allowable loads in **Table A** meet or exceed the design loads on the truss plan or the allowable loads for the connector being specified. For complete installation instructions and additional technical information, consult the **Truss and Rafter to Top Plate Technical Evaluation Report, TER No. 1503-03**, available at www.FastenMaster.com.

Table A Truss to Top Plate			
Allowable Loads (in Pounds per Connection)			
Wood Species	Uplift	Lateral/Shear	
		Parallel to Wall (F1)	Perpendicular to Wall (F2)
SPF	595	285	485
D. Fir	655	300	455
S. Fir	690	330	400

Footnotes

- Values taken from Technical Report TER #1503-03
- Loads adjusted to reflect wind load duration. No further increase allowed
- Where truss and plate members differ in species, use the lower density wood values
- Uplift values adjusted to allow for up to 1/4" of head exposed for ease of inspection

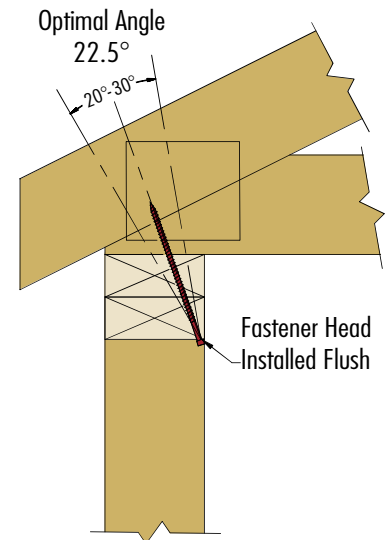

Installation Tips:

- **Directly over studs and headers** - The FrameFAST fastener can easily be installed when the truss or rafter lands between studs by driving the screw at an angle starting just under the leading edge of the plate. When directly over a stud or header, the fastener is installed at the seam between stud and plate or in the case of headers 3" from the bottom of the truss.
- **Fastener Depth** - This fastener is designed to be installed with the head either sunk flush with the wall framing or left up to 1/4" proud to allow for easier inspection. The unique design relies on threads under the head to resist uplift, not the head.
- **Girder Truss Applications** - The FrameFAST fastener and tool can be used in multi-ply girder applications, where two or more trusses are being attached close together. A reduction factor of 0.8 should be applied to the loads from **Table A** in this type of application.

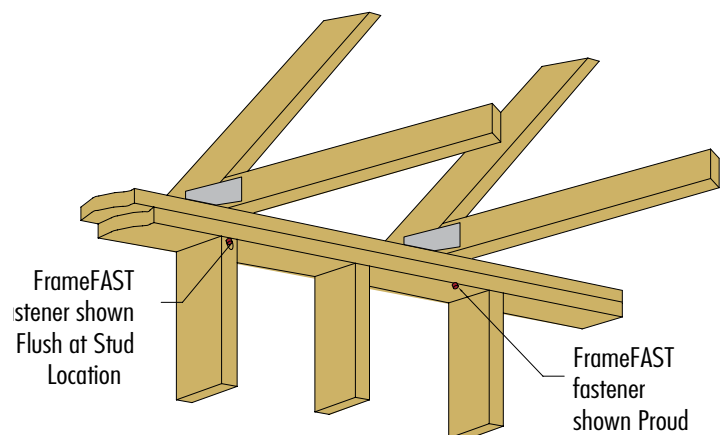

For technical support or to place an order: 800-518-3569 or www.FastenMaster.com

FRAMEFAST CONNECTIONS

B Stud to Top and Bottom Plate

Where increased wind or seismic conditions require the use of additional straps or ties to transfer uplift loads from plates into the wall studs, FrameFAST can be used as a substitute. By spacing the FrameFAST fastener 3-1/2" from the end of the stud and driving at a 30 to 35-degree angle through the stud and into the plate, additional uplift capacity can be achieved. The FrameFAST Tool, with its specifically designed head, can be used to ensure proper alignment and installation every time.

To verify the adequacy of this fastener to your specific application, confirm that the FrameFAST allowable loads in **Table B** meet or exceed the specified design loads or the allowable loads for the connectors being used. Fasteners at each stud may not be necessary: spacing may be adjusted to meet the required design loads. For complete installation instructions and additional technical information, consult the **Stud to Plate and Plate to Rim Board Technical Evaluation Report, TER No. 1801-02**, available at www.FastenMaster.com.

Table B Stud to Top and Bottom Plate	
Allowable Loads (in Pounds per Connection)	
Wood Species	Uplift
SPF	340
D. Fir	560
S. Fir	665

Footnotes

- Values taken from Technical Report TER #1801-02
- Loads adjusted to reflect wind load duration. No further increase allowed
- Where stud and plate members differ in species, use the lower density wood values

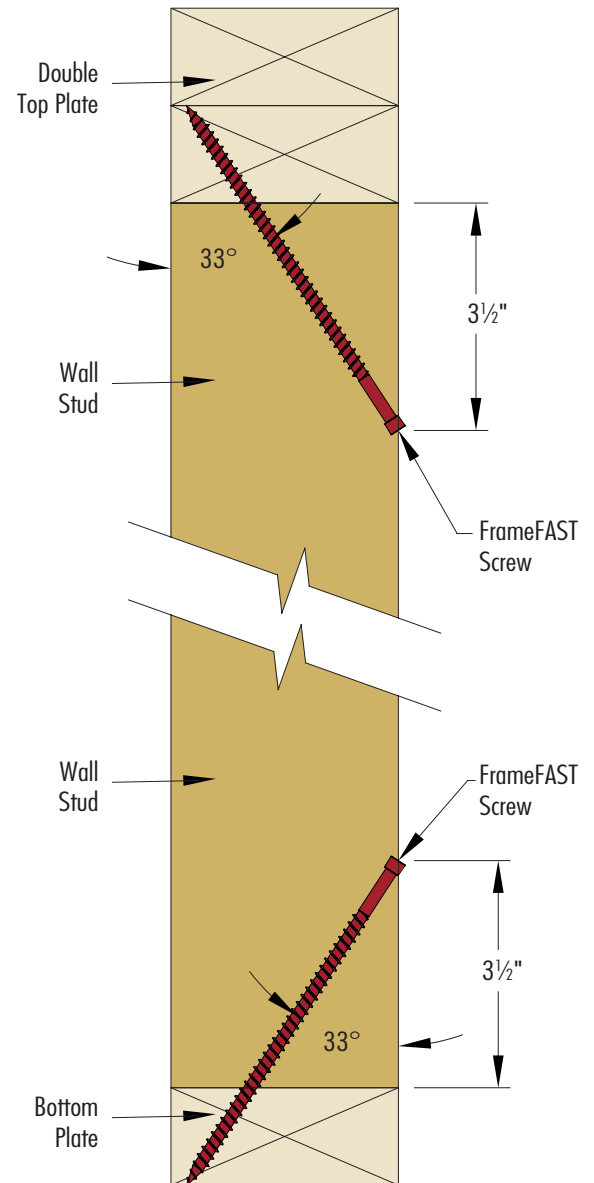

FRAMEFAST CONNECTIONS

C Top and Bottom Plate to Rim Board

Shear and uplift loads between floors frequently require additional connectors to supplement the sheathing on the exterior of the building used to transfer these forces. The FrameFAST can be used as a substitute for these connectors and can be more easily installed from the interior of the building. To install the FrameFAST in these connections, drive the fastener at a 10 to 15 degree angle beginning 1-1/2" from the outside edge of the plate. The FrameFAST Tool, with its specifically designed head, can be used to ensure proper alignment and installation every time.

Depending on the anticipated loads, these fasteners can be spaced at a frequency calculated using the allowable loads in Table C. For complete installation instructions and additional technical information, consult the **Stud to Plate and Plate to Rim Board Technical Evaluation Report, TER No. 1801-02**, available at www.FastenMaster.com.

Bottom Plate to Rim Board Connection

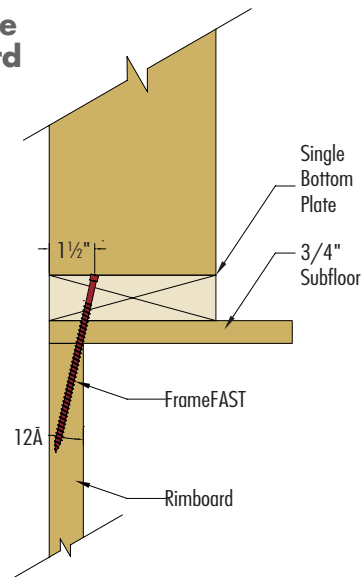

Top Plate to Rim Board Connection

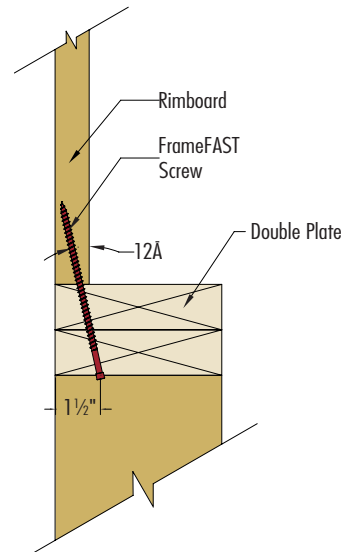

Table C Top or Bottom Plate to Rim Board

Allowable Loads (in Pounds per Connection)

Wood Species	Single Plate		Double Plate	
	Uplift	Lateral/Shear	Uplift	Lateral/Shear
SPF	210	340	475	495
D. Fir	245	265	590	595
S. Pine	325	395	595	700
1-1/8" OSB	195	340	360	230
1-1/4" LSL	165	210	610	485
1-1/4" LVL	110	320	570	440

Footnotes

- Values taken from Technical Report TER #1801-02
- Loads adjusted to reflect wind load duration. No further increase allowed
- Where stud and plate members differ in species, use the lower density wood values

For technical support or to place an order: 800-518-3569 or www.FastenMaster.com

FRAMEFAST CONNECTIONS

D Gable or Drag Truss

FrameFAST can be installed into gable and drag trusses to resist the increased uplift and shear loads resulting from wind and seismic events. The current methods for making these connections include the use of angled connectors and multiple nails. In most cases, the FrameFAST fasteners can be installed at equal or greater spacing than these connectors while maintaining the same loads.

To install the FrameFAST into these applications, drive the fastener from the underside of a single or double top plate and into the bottom truss chord. The fastener can be installed between 0 to 15 degrees.

To verify the adequacy of this fastener to your specific application, confirm that the FrameFAST allowable loads in **Table D** meet or exceed the specified design loads or the allowable loads for the connectors being used. For additional installation instructions or technical information, contact www.FastenMaster.com.

Gable Truss Connection

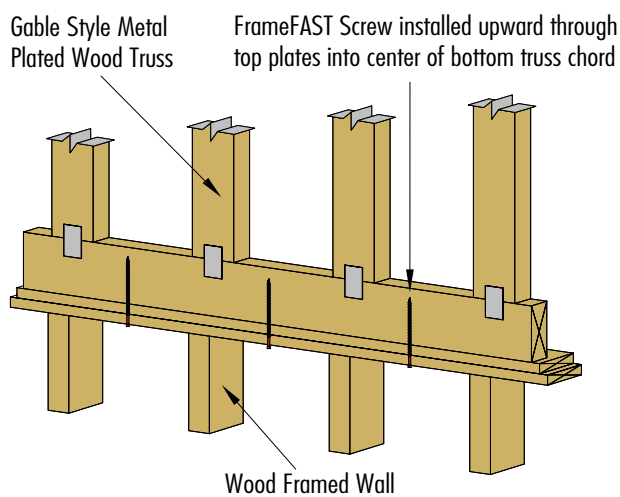

Drag Truss Connection

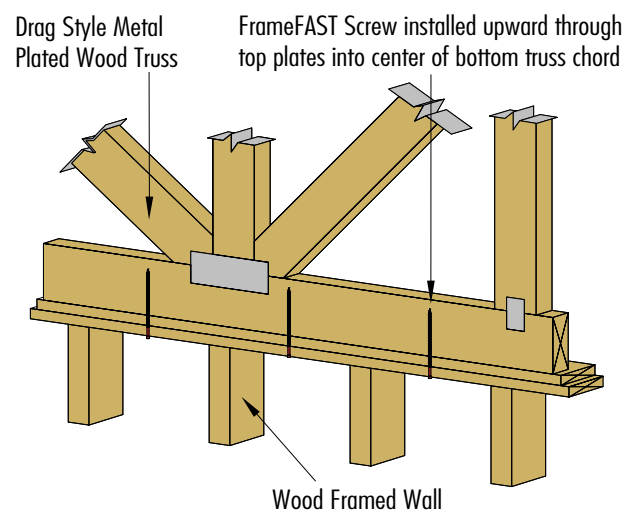

Table D Gable or Drag Truss to Plate

Allowable Loads (in Pounds per Connection)

Wood Species	Uplift	Lateral/Shear	
		Parallel to Wall (F1)	Perpendicular to Wall (F2)
SPF	595	285	485
D. Fir	655	300	455
S. Fir	690	330	400

Footnotes

- Values taken from Technical Report TER #1503-03
- Loads adjusted to reflect wind load duration. No further increase allowed
- Where truss and plate members differ in species, use the lower density wood values
- Uplift values adjusted to allow for up to 1/4" of head exposed for ease of inspection

FRAMEFAST CONNECTIONS

E Jack Stud to Header

In some cases, straps or ties may be used to transfer loads between the jack studs and headers above them. FrameFAST can be used as a substitute for these connectors in many of these instances. To install the FrameFAST, place the fastener 3-1/2" from the top of the stud and drive at a 30 to 35 degree angle through the stud and into the header. The FrameFAST Tool, with its specifically designed head, can be used to ensure proper alignment and installation every time.

To verify the adequacy of this fastener to your specific application, confirm that the FrameFAST allowable loads in **Table E** meet or exceed the specified design loads or the allowable loads for the connectors being used. For complete installation instructions and additional technical information, consult the **Stud to Plate and Plate to Rim Board Technical Evaluation Report, TER No. 1801-02**, available at www.FastenMaster.com.

Table E Jack Stud to Header	
Allowable Loads (in Pounds per Connection)	
Wood Species	Uplift
SPF	340
D. Fir	560
S. Fir	665

Footnotes

- Values taken from Technical Report TER #1801-02
- Loads adjusted to reflect wind load duration. No further increase allowed
- Where stud and header materials differ in species, use the lower density wood values

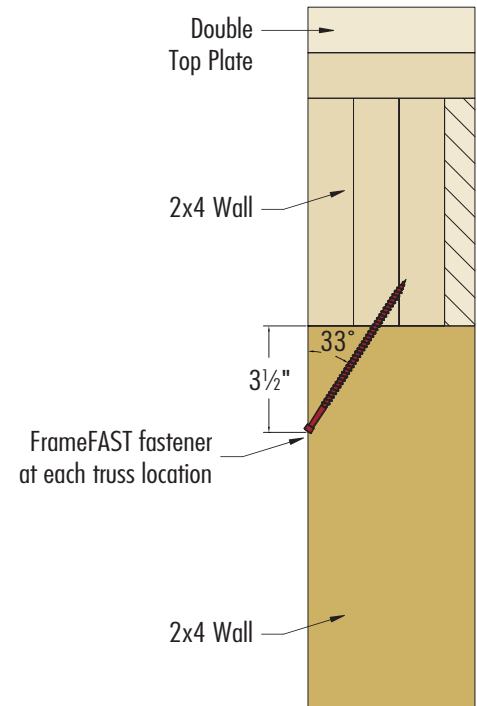

F Bottom Plate to Floor Truss

Where metal plated trusses are being used for floor and roof assemblies, the shear and uplift loads between the top plate of the wall and bottom chord of the trusses typically require additional connectors to collect these loads. FrameFAST can be used as a substitute for these connectors when making this connection. Where the truss lands between studs, drive a screw at an angle starting just under the leading edge of the plate. When directly over a stud or header, the fastener should be installed at an angle into the seam between stud and plate or on the face of the header 3" below the bottom of the truss.

To verify the adequacy of this fastener to your specific application, confirm that the FrameFAST allowable loads in **Table A** meet or exceed the specified design loads or the allowable loads for the connectors being used. In some cases, two fasteners may be used for increased loads. For additional installation instructions or technical information, contact www.FastenMaster.com.

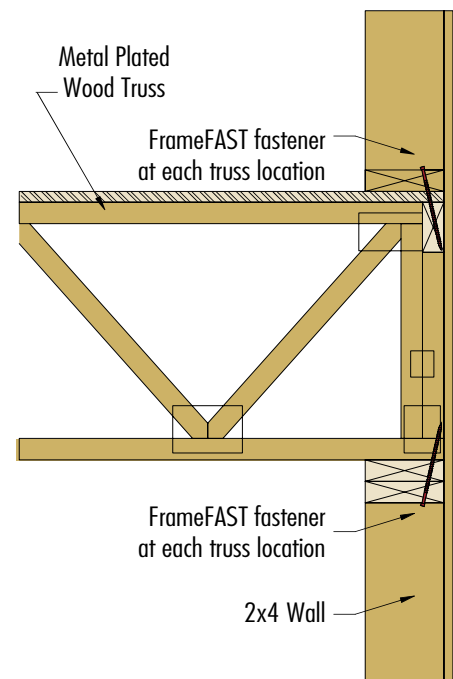

For technical support or to place an order: 800-518-3569 or www.FastenMaster.com

TimberLOK®

PRODUCT SPECIFICATION

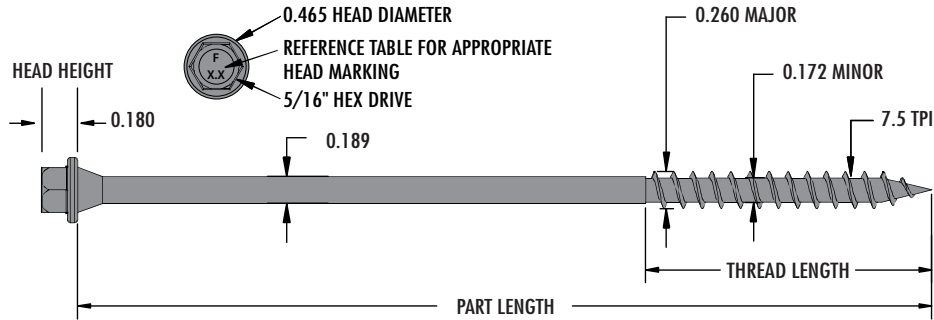

TimberLOK Selection Guide			
Part Length	Thread Length	Head Markings	Part Number
2 1/2"	1 1/4"	F2.5	FMTLOK212
4"	2"	F4.0	FMTLOK04
6"	2"	F6.0	FMTLOK06
8"	2"	F8.0	FMTLOK08
10"	2"	F10.0	FMTLOK10

TIMBERLOK SAMPLE APPLICATIONS

Truss/Rafter to Top Plate Connection

The 6" TimberLOK® can be used in many cases as a replacement for hurricane ties used to resist uplift and lateral loads on trusses and rafters attached to the top plates of the wall. To verify the adequacy for your specific connection, make sure the allowable loads in **Table A** exceed the design loads on the plan or allowable loads for the connector being specified. For instructions and additional technical information, consult the **Truss and Rafter to Top Plate Technical Evaluation Report, TER No. 1105-02**, available at www.FastenMaster.com.

Table A Allowable Loads (160)								
Uplift			Shear Parallel to Wall			Shear Perpendicular to Wall		
SPF H. Fir	D. Fir	S. Pine	SPF H. Fir	D. Fir	S. Pine	SPF H. Fir	D. Fir	S. Pine
410	510	570	340	380	410	370	420	450

Table A Footnotes

- A standard wind load duration factor of 1.6 has been applied per NDS Table 2.3.3. Adjustments to lower this factor may be made at the engineers discretion. No further increase allowed
- Assumes a nominal 2x truss chord installed over double top plate or 3" of solid wood
- For applications with members of different species, use the allowable load corresponding to the lowest specific gravity
- Tabulated loads based on ICC-ES Report ESR #1078. Additional third party system testing used to confirm values and adequacy of edge and end distances

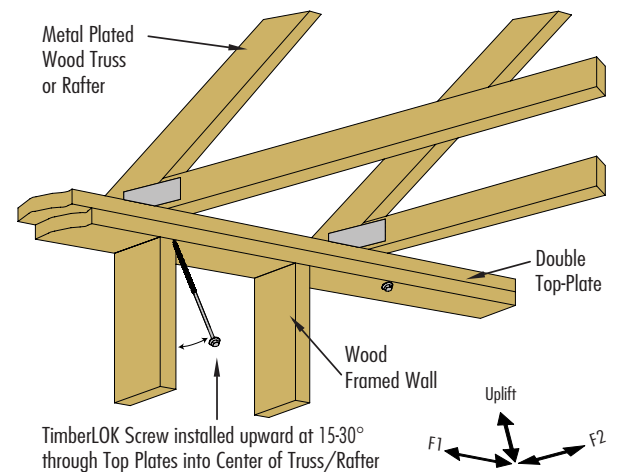

Gable Truss Connection and Drag Truss Connection

The 4" and 6" TimberLOK® can be used in gable and drag trusses to resist the uplift and shear forces from wind and seismic events. The current methods for making these connections include the use of angled connectors and multiple nails. In most cases, the TimberLOK fasteners can be placed at equal or greater spacing than the ties they are replacing. Refer to **Table B** for proper design of these connections. For instructions and additional technical information, consult the **Gable Truss to Top Plate Technical Evaluation Report, TER No. 1304-02**, or **Drag Strut to Wall Plate Technical Evaluation Report, TER No. 1306-01**, available at www.FastenMaster.com.

Uplift			Shear Parallel to Wall			Shear Perpendicular to Wall		
SPF/H. Fir	D. Fir	S. Pine	SPF/H. Fir	D. Fir	S. Pine	SPF/H. Fir	D. Fir	S. Pine
410	510	570	370	420	420	340	380	380

Table B Footnotes

- A standard wind load duration factor of 1.6 has been applied per NDS Table 2.3.3. Adjustments to lower this factor may be made at the engineers discretion. No further increase allowed
- Assumes a nominal 2x truss chord installed over 2x rim, single or double top plate
- For applications with members of different species, use the lowest allowable load to design the connection
- Tabulated loads based on ICC-ES Report ESR #1078. Additional third party system testing used to confirm values and adequacy of edge and end distances

Gable Truss Connection

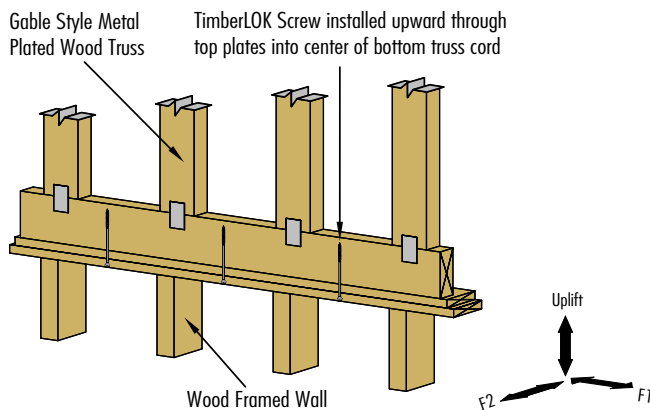

Drag Truss Connection

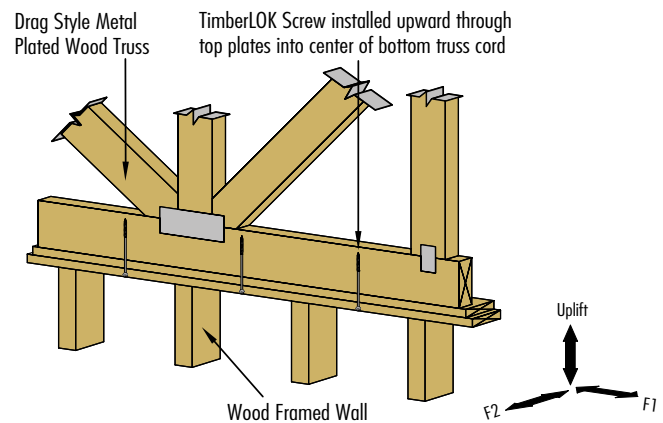

Shear Wall Connection

The 4", 6" and 8" TimberLOK® can be used in shear wall or portal frame construction to resist the shear forces exerted on the top and bottom wall plates to the adjacent rim. Typically, the shear being transferred between these plies can only be accomplished through the use of excessive nail patterns. The increased strength of the TimberLOK fastener, as shown in **Table C**, allows for greater connection strength with significantly less fasteners. For instructions and additional technical information, consult the **Wall to Rim Joist Technical Evaluation Report, TER No. 1306-05**, available at www.FastenMaster.com.

Shear Parallel to Wall		Shear Perpendicular to Wall	
SPF/H. Fir	D. Fir/S. Pine	SPF/H. Fir	D. Fir/S. Pine
340	380	370	420

Table C Footnotes

- A standard wind load duration factor of 1.6 has been applied per NDS Table 2.3.3. Adjustments to lower this factor may be made at the engineers discretion. No further increase allowed
- Assumes full thread penetration into wood rim board with a minimum 2" nominal thickness
- Tabulated loads based on ICC-ES Report ESR #1078. Additional testing to ASTM D-1761 used to confirm adequate minimum edge and end distances
- For applications with members of different species, use the lowest allowable load to design the connection

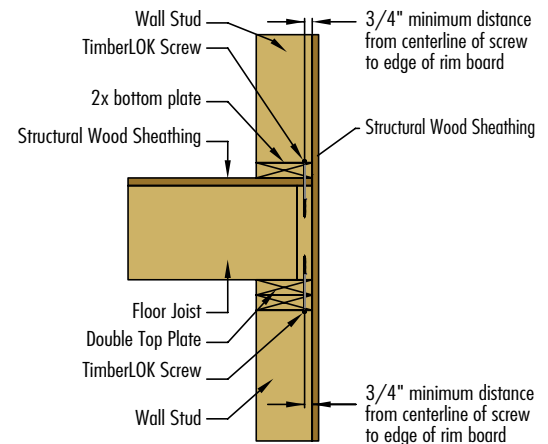

For technical support or to place an order: 800-518-3569 or www.FastenMaster.com

HeadLOK[®]

PRODUCT SPECIFICATION

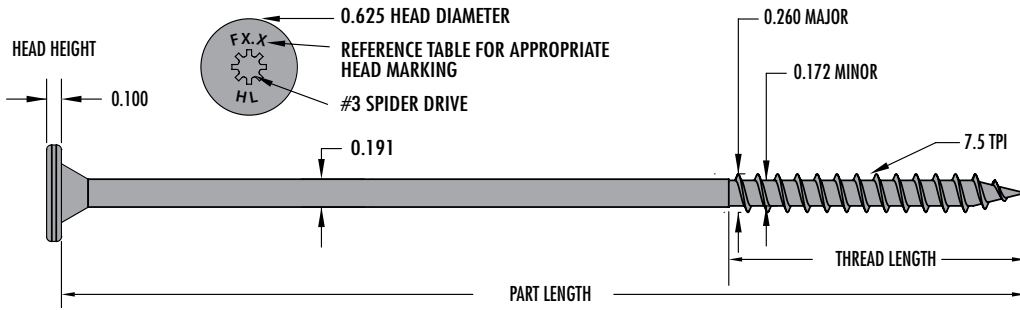

HeadLOK Selection Guide			
Part Length	Thread Length	Head Markings	Part Number
2 7/8"	2"	F2.9HL	FMHLGM278
4 1/2"	2"	F4.5HL	FMHLGM412
6"	2"	F6.0HL	FMHLGM006

Other Lengths: 1 5/8", 3 3/4", 5", 5 1/2", 6 1/2", 7", 7 1/2", 8", 8 1/2", 9", 9 1/2", 10", 11", 12", 13", 14", 15", 16", 18"

HEADLOK SAMPLE APPLICATION

Attachment of Furring or Sheathing over Rigid Foam

Recent changes in the Energy Code have resulted in an increased use of rigid insulation over exterior walls. Attaching the finish materials (siding) requires a furring strip or sheathing be mechanically attached to the structural framing of the building over the insulation layer. The HeadLOK has been tested and approved for use in this unique cantilevered condition. A guide to proper fastening is shown in **Table A**. For instructions and additional technical information, consult the **Rigid Foam to Wood Framing Technical Evaluation Report, TER 1009-01**, at www.FastenMaster.com.

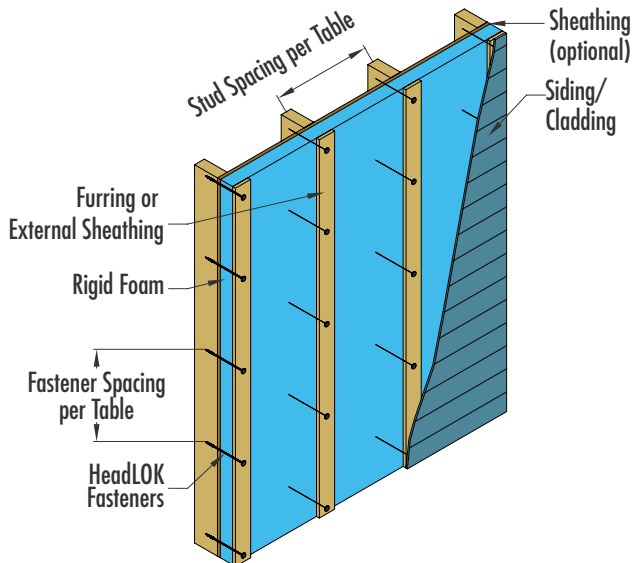

HeadLOK Allowable Loads									
Withdrawal			Head Pull Through			Shear			
						Perp. to Grain		Parallel to Grain	
SPF/H.Fir	D.Fir	S.Pine	SPF/H.Fir	D.Fir	S.Pine	SPF/H.Fir	D.Fir/S.Pine	SPF/H.Fir	D.Fir/S.Pine
340	440	520	400	520	600	230	270	250	290

Footnotes

- Values above taken from ICC Evaluation Report ESR #1078
- Loads have not been increased to accommodate for NDS load durations or other factors
- Withdrawal values assume full thread penetration into main member
- Head pull through values assume 1 1/2" or greater side member under head
- Shear values assume a min. side member thickness of 1 1/2" & main member thickness of 2 1/2"

Table A Rigid Foam Application					
Recommended Spacing Between Fasteners - Inches					
Exterior Layer	Foam Thickness Inches	Max. Allowable Cladding Weight (psf) to be Supported			
		10	15	20	25
1 x 4 Furring over Foam	1				
	1.5		24	16	
	2				12
	3	16	12	8	
4				NA	
3/8" Sheathing over Foam	1				
	1.5		12		
	2				
	3			8	
4				6	

Table A Footnotes

- Table patterns generated through testing and reported in TER 1009-01
- Assumes 2" minimum thread engagement into stud or stud/sheathing
- Patterns based on 24" on center stud spacing. Less restrictive patterns available for 16" stud spacing in TER 1009-01

LedgerLOK[®]

PRODUCT SPECIFICATION

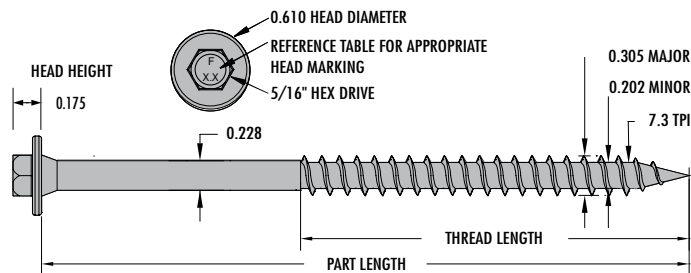
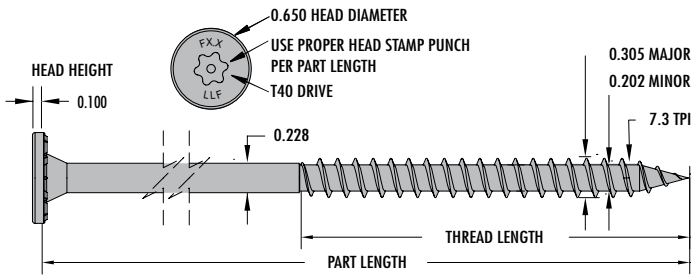

LedgerLOK Selection Guide

Hex Head Selection Guide

Part Length	Thread Length	Head Markings	Part Number
3 5/8"	2"	F3.6	FMLL358
5"	3"	F5.0	FMLL005

Flat Head Selection Guide

Part Length	Thread Length	Head Markings	Part Number
3 5/8"	2"	LLF3.6	FMLLF358
5"	3"	LLF5.0	FMLLF005

LedgerLOK Allowable Loads

Shear		Withdrawal	
SPF/H. Fir	D. Fir/S. Pine	SPF/H. Fir	D. Fir/S. Pine
250	310	315	405

Footnotes

- Values above taken from ICC Evaluation Report ESR #1078
- Loads have not been increased to accommodate for NDS load durations or other factors
- Shear values assume a minimum side member of 1 1/2" and main member of 1 1/2"
- Withdrawal loads assume a minimum side thread penetration of 1 1/2" into rim board

LEDGERLOK APPLICATION

Deck Ledger to Rim Board Connection

One of the most critical connections when designing and building an exterior deck is between the deck ledger and the rim board of the house. Recent changes in code have addressed this application with specific lag screw spacing requirements. The LedgerLOK has been designed and tested to make this attachment in a code compliant manner without the need for predrilling. Refer to **Table A** for a general fastening guide. For instructions and additional technical information, consult the **Deck Ledger to Rim Technical Evaluation Report**, TER No. 1203-03, available at www.FasterMaster.com.

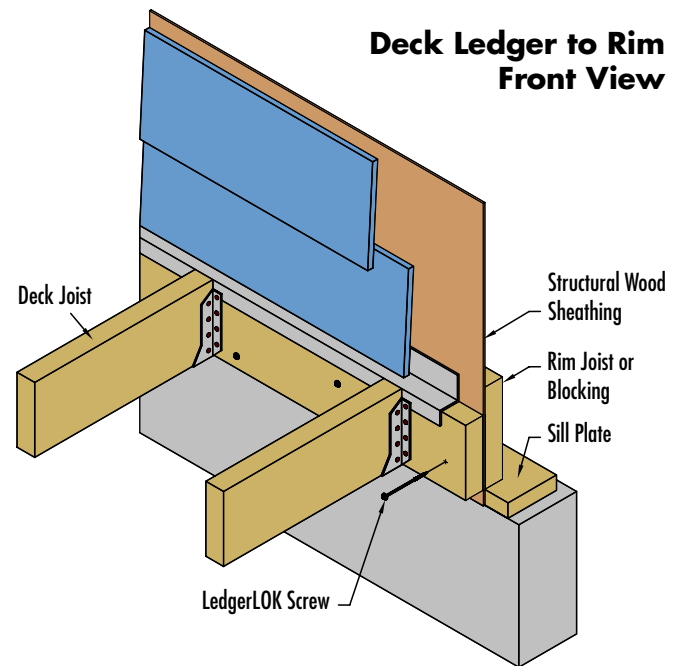

Footnote

- Fasteners should be installed in a staggered pattern at least 1 3/4" from top or bottom edge and 3 3/4" from end of the ledger and rim board

Table A Ledger to Rim Application

IRC Code Compliant Spacing of LedgerLOK Fasteners							
Max. span from ledger to beam	6'	8'	10'	12'	14'	16'	18'
Spacing between fasteners	20"	15"	12"	10"	8"	7"	6"

Table A Footnotes

- Assumes 2 x 8 or greater nominal ledger board of treated Hem Fir or denser wood (D. Fir, S. Pine)
- Rim board may be 1" or greater in thickness and SPF or denser wood including LSL engineered wood rim material
- Spacing based on 40 psf live load and 10 psf dead load conditions. Adjustments made for wet service conditions
- Tabulated loads based on ICC-ES Report ESR #1078. Additional third party system testing to ASTM D-1761 used to provide equal strength to IRC Table 502.2.2 (2009)

For technical support or to place an order: 800-518-3569 or www.FasterMaster.com

FlatLOK[®]

PRODUCT SPECIFICATION

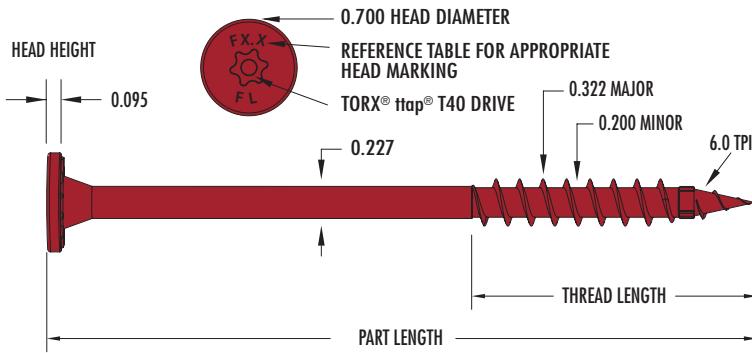

FlatLOK Selection Guide			
Part Length	Thread Length	Head Markings	Part Number
2 7/8"	1 3/4"	F2.9	FMFL278
3 1/2"	2"	F3.5	FMFL312
4"	2"	F4.0	FMFL004
4 1/2"	2"	F4.5	FMFL412
5"	2"	F5.0	FMFL005
6"	2"	F6.0	FMFL006
6 3/4"	2"	F6.7	FMFL634

Table A Uniform Side Load Capacity (plf) Engineered Beam

A	B	C	D	E	F		
1 3/4" 1 3/4"	1 3/4" 1 3/4" 1 3/4"	1 3/4" 3 1/2"	1 3/4" 3 1/2" 1 3/4"	3 1/2" 3 1/2"	1 3/4" 1 3/4" 1 3/4" 1 3/4"		
3 1/2"	5"		6 3/4"				
Rows	Spacing	Detail A	Detail B	Detail C	Detail D	Detail E	Detail F
2	24	660	490	490	440	660	440
2	16	990	740	740	660	990	660
2	12	1320	980	980	880	1320	880
3	16	1480	1110	1110	990	1480	990
3	12	1980	1480	1480	1320	1980	1320
4	12	2640	1970	1970	1760	2640	1760

Table A Footnotes

- Values above calculated using individual FlatLOK properties taken from testing to ICC-ES Acceptance Criteria AC233
- Loads have not been increased to accommodate for NDS load duration or other factors

FLATLOK SAMPLE APPLICATIONS

Multiple-Ply Engineered Wood Beam Connection

When joining together multiple plies of engineered wood together to act as a single beam, nailing patterns are typically aggressive, only satisfy up to three plies and require access to both sides. Through-bolts can be used to reduce the number of fasteners but require considerably more labor and cost to install.

The FlatLOK has been designed specifically to be installed from one side and to carry both top and side loads. Refer to the details below for common application guide lines. For more detailed design information, refer to Technical Evaluation Report, TER No. 1501-08 available at www.FastenMaster.com.

Top Loaded Beams

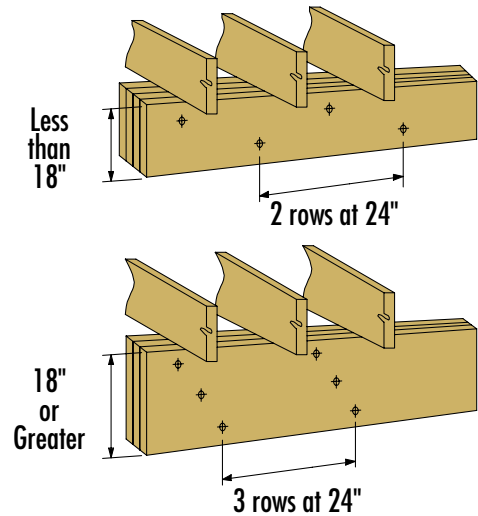

Side Loaded Beams

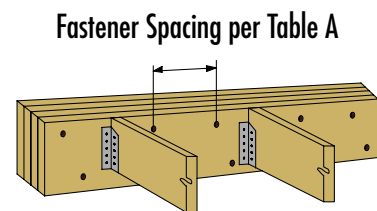

Footnotes

- Fasteners should be installed in a staggered pattern at least 1 3/4" from top or bottom edge and 3 3/4" from either end of the beam

Multiple-Ply Wood Truss Connection

Multiple roof trusses coupled together, commonly referred to as girder trusses, are used to address increased loads concentrated or uniformly applied to roof framing members. Nails are typically used to join these plies but can loosen during the truss installation process. Bolts are another option but require significantly more installation time and expense. The FlatLOK, installed from one side for up to four plies, makes this task easier and stronger than the other options. A design professional should be consulted to determine the proper fastener placement using the **Allowable Load Table B**. For more detailed information, consult the **TER 1501-08** available at www.FastenMaster.com.

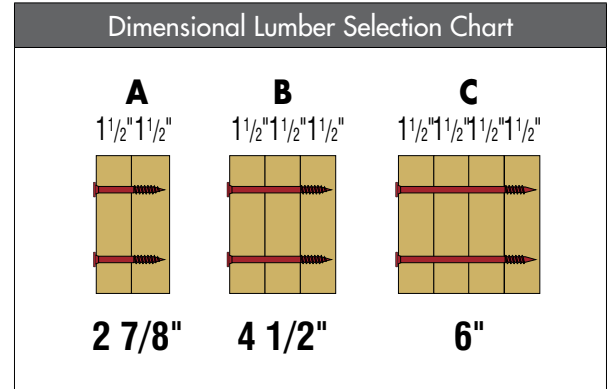

Table B Allowable Load Capacity (plf) Dimensional Beam														
Spruce-Pine-Fir					Douglas-Fir					Southern Pine				
Rows	Spacing	Detail A	Detail B	Detail C	Rows	Spacing	Detail A	Detail B	Detail C	Rows	Spacing	Detail A	Detail B	Detail C
2	24	400	300	270	2	24	520	390	350	2	24	580	430	390
2	16	600	450	400	2	16	780	580	520	2	16	870	650	580
2	12	800	600	530	2	12	1040	780	690	2	12	1160	870	770
3	16	900	670	600	3	16	1170	870	780	3	16	1300	970	870
3	12	1200	900	800	3	12	1560	1160	1040	3	12	1740	1300	1160
4	12	1600	1200	1070	4	12	2080	1550	1390	4	12	2320	1730	1550

Table B Footnotes

- Values above calculated using individual FlatLOK properties taken from testing to ICC-ES Acceptance Criteria AC233
- Loads have not been increased to accommodate for NDS load duration or other factors

Multi-Ply Truss Connection

Metal Plated Roof Trusses

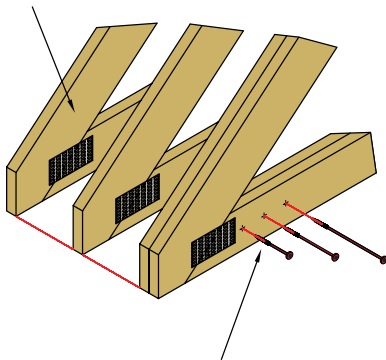

FlatLOK fastening pattern per truss manufacturer

Multi-Ply Dimensional Lumber Beam

Dimensional Wood Beams

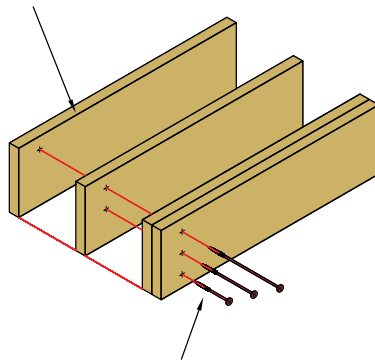

FlatLOK fastening pattern per building designer

Multi-Ply Dimensional Lumber Column

Dimensional Wood Column

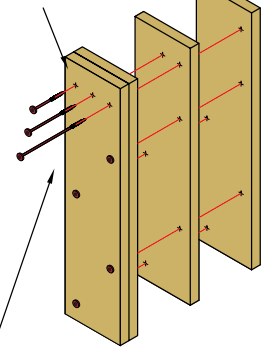

FlatLOK fastening pattern per building designer

For technical support or to place an order: 800-518-3569 or www.FastenMaster.com

FLATLOK SAMPLE APPLICATIONS

Ledger to Stud Configurations

Ledgers are used for interior construction to support corridor floor spans and stairwell landings. In most cases these are installed over layers of gypsum to achieve the appropriate fire rating and then into vertical studs. These unique conditions require a tested solution that considers both the cantilevered portion of the fastener and narrower edge of the framing used to make this connection. The FlatLOK has been evaluated and loads determined for this specific application when installed in accordance with the details below. For more detailed design information, refer to Technical Evaluation Report, TER No. 1611-01 available at www.FastenMaster.com.

2 x 6 Ledger

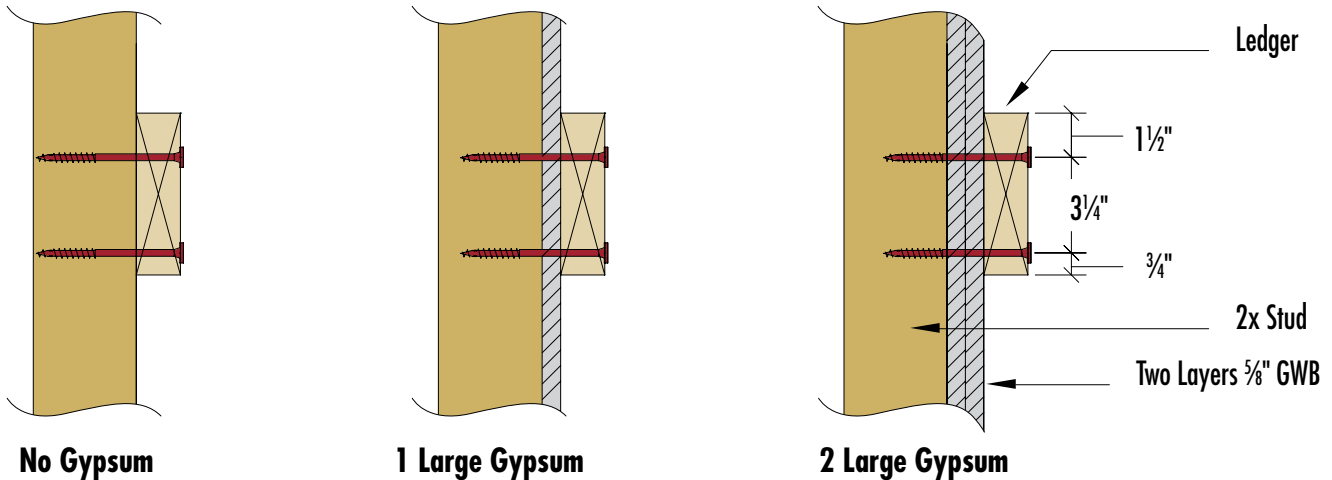

2 x 8 Ledger

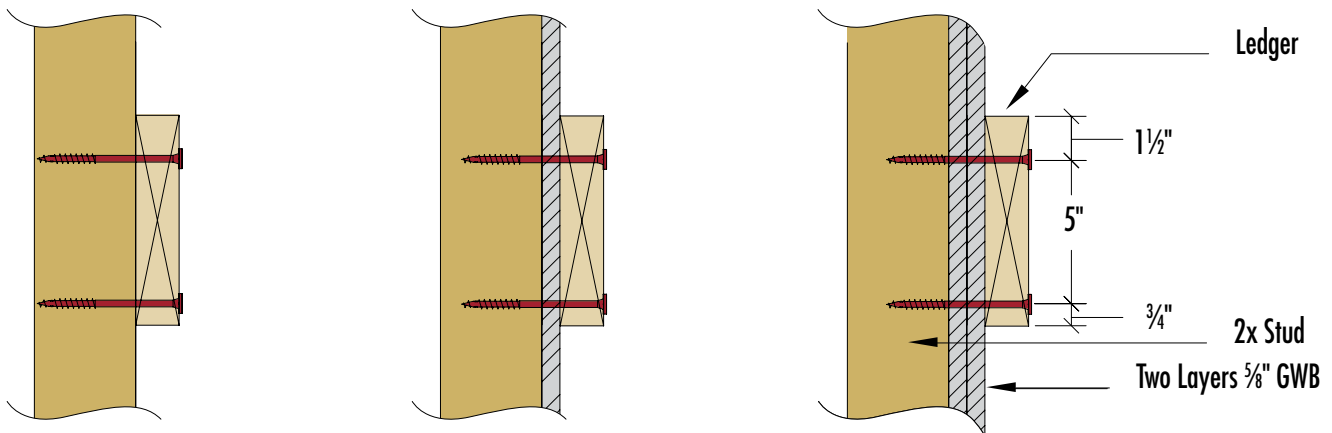

2 x 10 Ledger

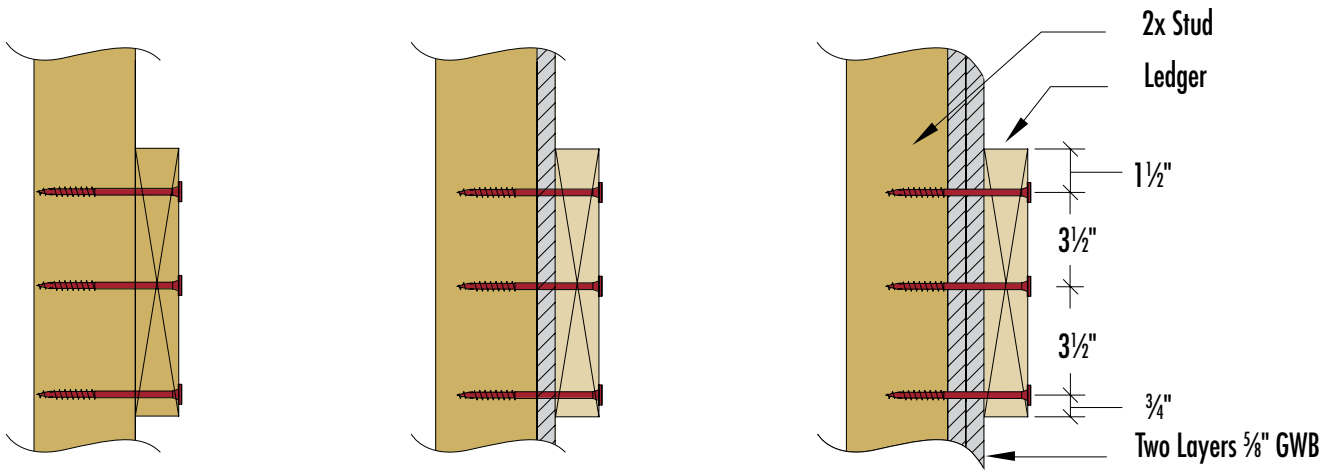

For technical support or to place an order: 800-518-3569 or www.FastenMaster.com

ThruLOK[®]

PRODUCT SPECIFICATION

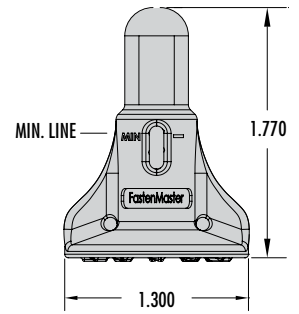
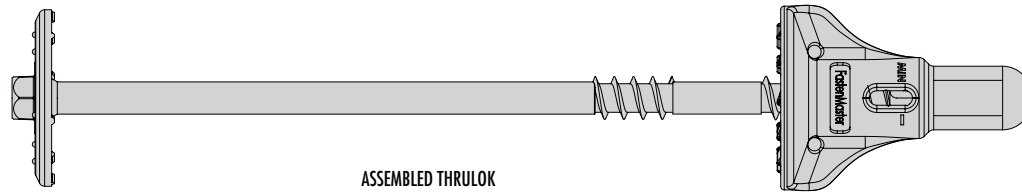
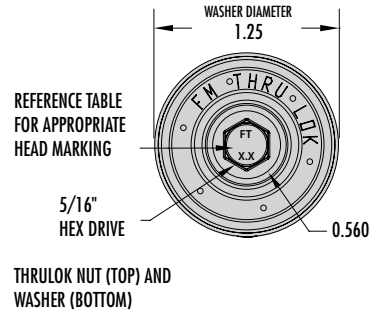
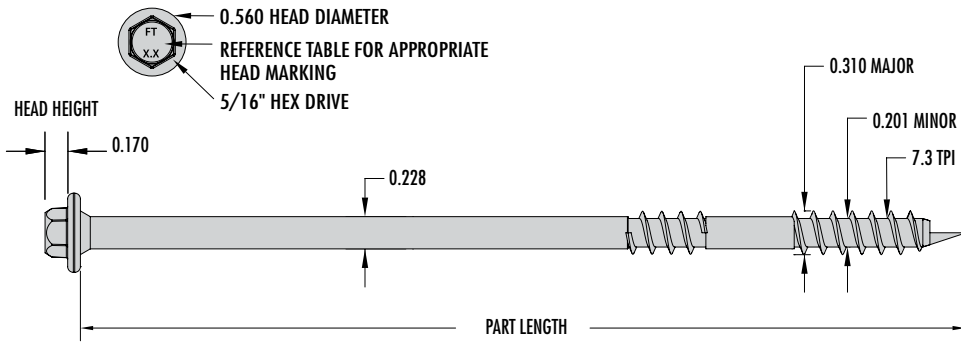

ThruLOK Selection Guide				
Part Length	Application Thickness		Head Markings	Part Number
	Minimum	Maximum		
6 1/4"	4 1/2"	5 1/4"	FT6.2	FMTHR614
7"	5 1/4"	6"	FT7.0	FMTHR007
8"	6 1/4"	7"	FT8.0	FMTHR008
9 1/2"	7 3/4"	8 1/2"	FT9.5	FMTHR912

ThruLOK Application Guide			
6 1/4"	5"	5 1/4"	
	2x to 4x	3 ply EW	
7"	5 1/2"	5 1/2"	6"
	Notched 6x	Notched 6x	4 ply 2x
8"	6 1/2"	6 1/2"	7"
	Double 2x to 4x	2x to 4x to 2x	4 ply EW
9 1/2"	8 1/2"		
	2x to 6x to 2x		

ThruLOK Allowable Loads						
Withdrawal & Head Pull Through			Shear			
			Perpendicular to Grain		Parallel to Grain	
SPF/H.Fir	D.Fir	S.Pine	SPF/H.Fir	D.Fir/S.Pine	SPF/H.Fir	D.Fir/S.Pine
680	900	1060	270	300	320	350

- Footnotes**
- Values above taken from ICC Evaluation Report ESR #1078
 - Loads have not been increased to accommodate for NDS load durations or other factors
 - Withdrawal & head pull through values assume fastener threaded into nut at least to "Min Line"
 - Shear and withdrawal values assume a minimum side member thickness of 1 1/2"

THRULOK SAMPLE APPLICATIONS

Pole Barn Header Connection

A typical detail in pole barn construction consists of 2x beams mounted to face or faces of 6x columns. Prefabricated trusses are then placed atop these beams. Bolting of the connections between column and beam(s) has become more common and in some states required by code. When properly installed, the ThruLOK Fastener can replace bolts. For instructions and additional technical information, consult the **Pole Barn Header Connection Technical Evaluation Report, TER 1308-11**, available at www.FastenMaster.com.

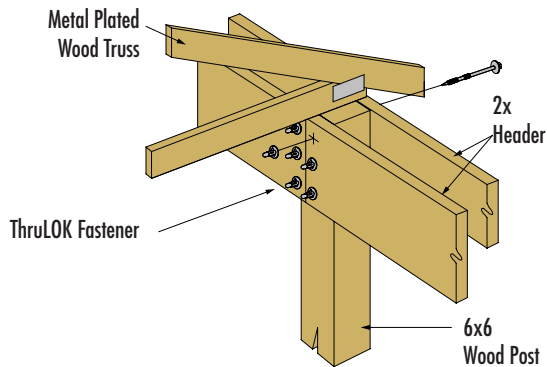

Sample Fastening Schedule for Header to Column Connections				
Total Building Width	Header & Column Species	Snow Load on Truss		
		20	30	40
		Number of Fasteners per Connection		
24	Hem Fir	4	6	6
	D.Fir / S.Pine	4	4	6
28	Hem Fir	6	6	8
	D.Fir / S.Pine	4	6	6
32	Hem Fir	6	8	8
	D.Fir / S.Pine	6	6	8
36	Hem Fir	6	8	NA
	D.Fir / S.Pine	6	6	8
40	Hem Fir	6	8	NA
	D.Fir / S.Pine	6	6	8

Footnotes

- Values above calculated using individual ThruLOK values from ICC Evaluation Report ESR #1078
- Assumed loads of 10 plf for Bottom Chord (BC) Live and 5 plf BC Dead added to snow loads
- Maximum column spacing of 8' on center with trusses nearest columns resting atop column
- Table to be used as a guide only. Refer to TER 1308-11 for complete instructions & restrictions

Deck Carrying Beam Connection

A common method of deck construction allows for carrying beams and notched 6x6 support posts to be bolted together using 1/2" or 5/8" through bolts. According to current code, "where posts and beam or girders construction is used to support floor framing, positive connections shall be provided to ensure against uplift and lateral displacement." When installed correctly, the 7" ThruLOK restrains against both of these forces equal to traditionally bolted connections with a faster and easier method of installation. For proper installation instructions including engineered solutions for the most common post to carrying beam configurations, refer to the **Deck Carrying Beam to Support Post** technical bulletin, at www.FastenMaster.com.

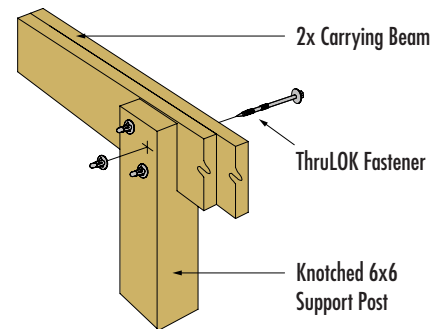

Deck Rail Post Connection

Current building code requires that guardrails and handrails must be designed to withstand a single concentrated load of 200 pounds in any direction. A critical part of this connection is making a strong tension connection between the guardrail post and the rim board of the deck. In most cases, 1/2" through-bolts or carriage bolts are used to make this connection. When installed as shown in our instructions, the ThruLOK offers a faster and easier method to meet the 200 pound design load for this part of the connection. For proper installation instructions including engineered solutions for the most common post to rim configurations, refer to the **Deck Hand Rail Post to Rim Joist** technical bulletin, at www.FastenMaster.com.

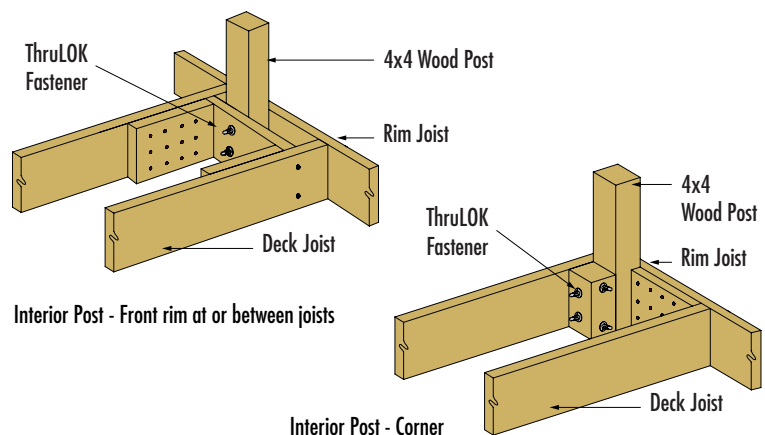

For technical support or to place an order: 800-518-3569 or www.FastenMaster.com

Lateral Tension System™

PRODUCT SPECIFICATION

Tension Transfer Screw

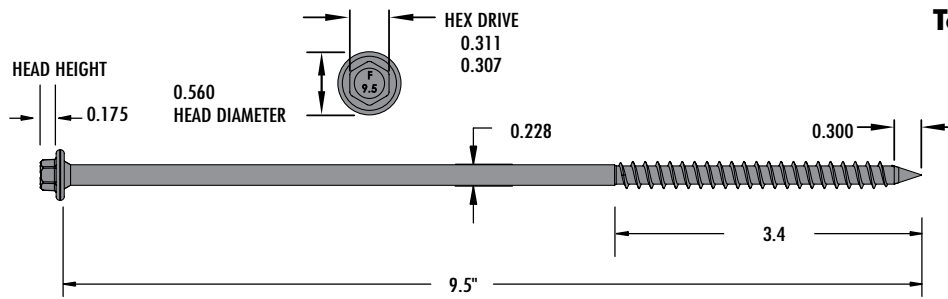

LTS Bracket Top View

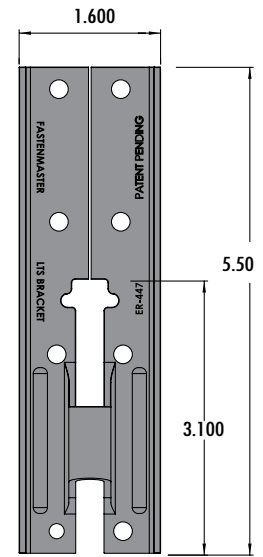

Bracket Mounting Screw

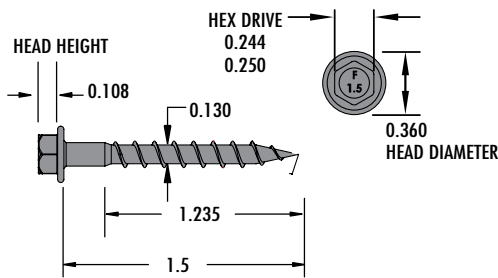

LTS Bracket Profile

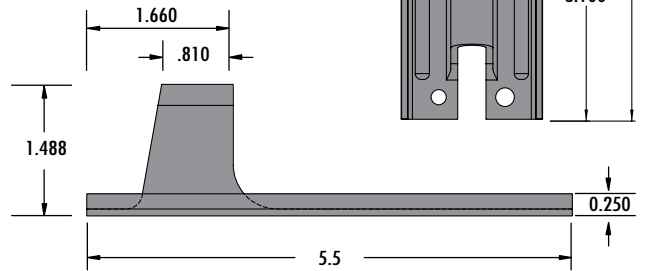

LTS APPLICATIONS

The 2015 code introduced a much easier and less invasive alternative method. This newest version allows for tension ties to be attached to the deck joist then fastened directly to an interior sill plate, wall plate or stud – all from the outside. These lateral connections must be designed to resist 750 pounds in tension and installed in four locations along the length of the ledger: one within 2' of each end of the ledger with two more evenly spaced between (see sample below). The FastenMaster (LTS) is a complete system designed to transfer the lateral forces on an exterior deck when attached to the wood frame of a structure. When installed per the enclosed instructions these connections meet the lateral load requirement in Section R507 of the International Residential Code.

Lateral Tension System Selection Guide

Part Length	Thread Length	Head Markings	Part Number
9-1/2"	3.4"	F 1.5	FMLTS4

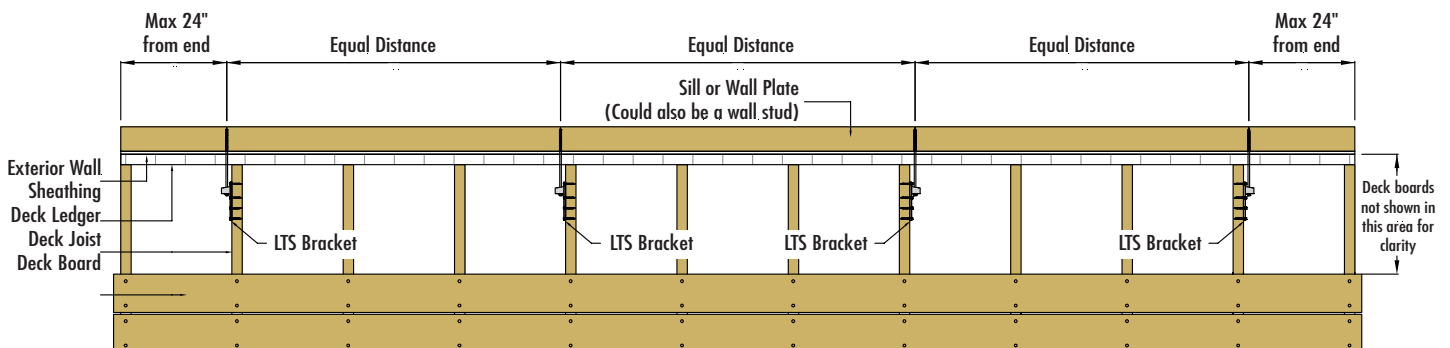

LATERAL TENSION SYSTEM SAMPLE APPLICATIONS

Select the appropriate ledger alignment condition, A through E, based on the orientation of the deck ledger to house framing member that applies to your specific deck. For instructions and additional technical information, consult the **Lateral Tension System Technical Evaluation Report**, available at www.FastenMaster.com.

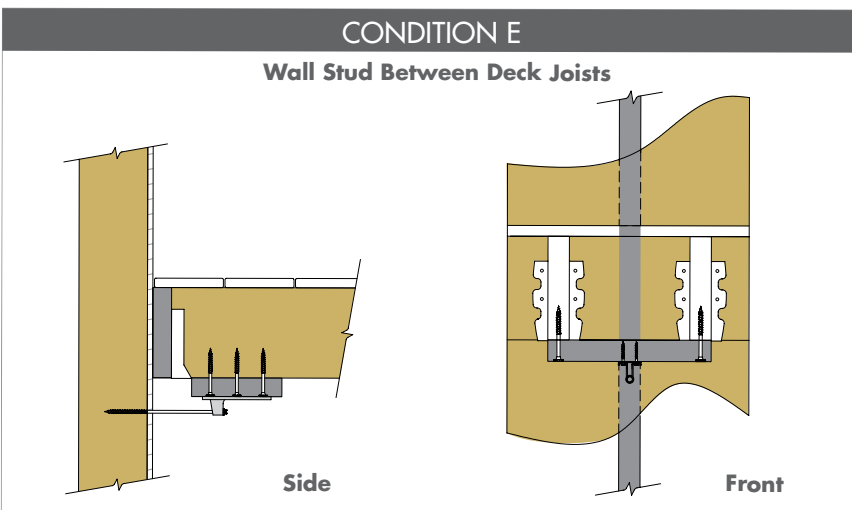
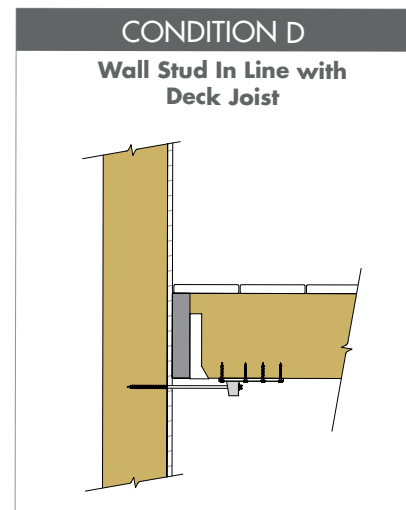
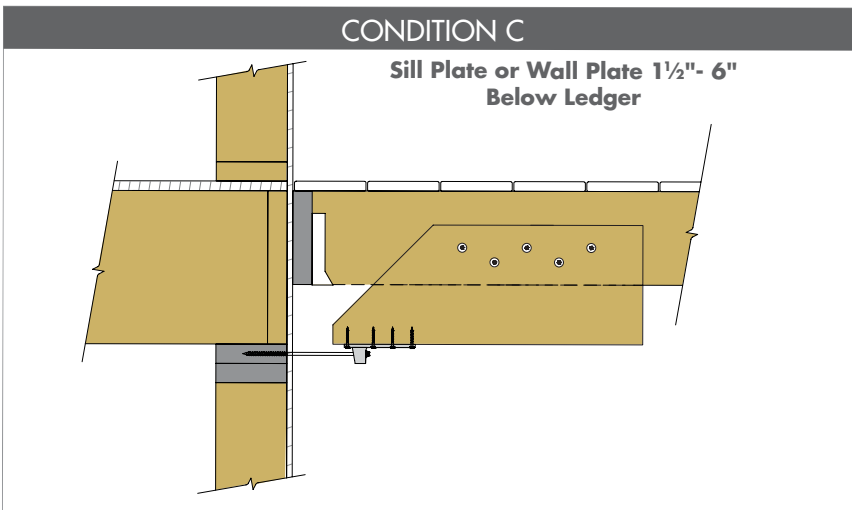
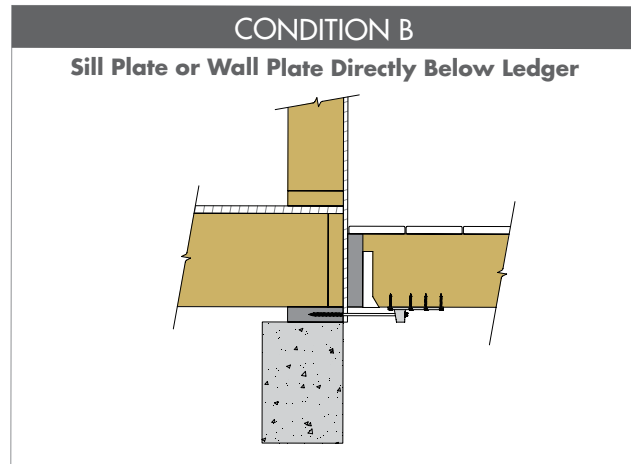
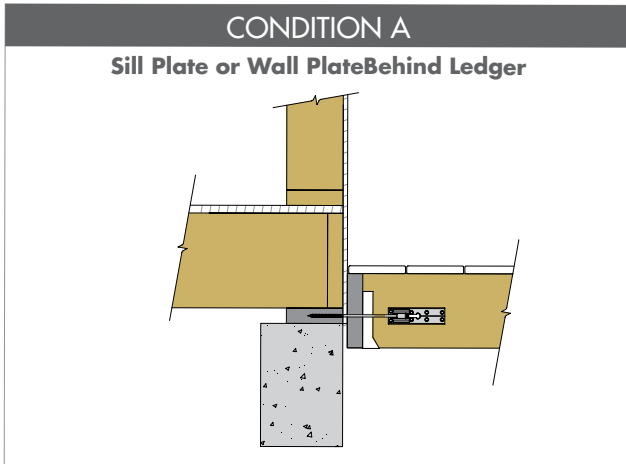

For technical support or to place an order: 800-518-3569 or www.FastenMaster.com