

TJI® Joists with a Side Flange Notch in the Top (Compression) Flange

The flange of a TJI® joist should never be deliberately cut or notched and TJI® joists subject to damage prior to installation should be discarded and replaced. However, it is recognized that an inadvertent notch to the flange of a TJI® joist may occur during the construction process, after the member has been installed. This technical bulletin provides contingency guidelines for TJI® joists with one (1) inadvertent *Side Flange Notch* in the top (compression) flange.

Definitions

- **Side Flange Notch** – notch type that encompasses the full flange depth and up to half the flange width

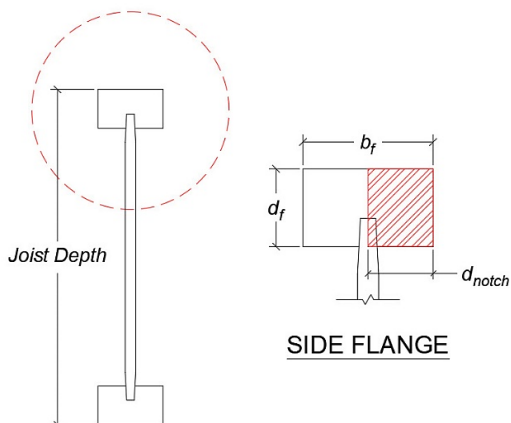

TJI® JOIST FLANGE MATERIAL & DIMENSIONS

TJI® Series	Flange	b_f	d_f
TJI® 110	LVL	1 3/4"	1 1/4" - 1 3/8"
TJI® 210	LVL	2 1/16"	1 1/4" - 1 3/8"
TJI® 230	LVL	2 5/16"	1 1/4" - 1 3/8"
TJI® 360	LVL	2 5/16"	1 3/8"
TJI® 560	LVL	3 1/2"	1 3/8"

Figure 1: Diagram of an inadvertent *Side Flange Notch* in top (compression) flange of a TJI® joist.

Conditions and Limitations

- Span tables are valid for flange notch contingency only.
- Original, undamaged TJI® joists are properly designed.
- Adjacent TJI® joists on both sides remain undamaged.
- Uniform distributed loads only.
- One (1) inadvertent *Side Flange Notch* per TJI® joist (single-ply joist members only).
- *Side Flange Notch* permitted in location zones of top (compression) flange (see Figure 4 and Figure 5).
- Notch depth (d_{notch}) \leq half the flange width (b_f).
- Length (parallel to span) of *Side Flange Notch* \leq 4".
- Centerline of *Side Flange Notch* \geq 6" from nearest edge of rectangular or slotted holes.
- *Side Flange Notch* due to saw-cuts or drilling only.
 - Excludes flange damage due to rough handling, drops, forklift stabs, etc.
- Joist member slope \leq 0.25/12.

Should your situation conflict with any of the conditions and limitations, please consider an alternative option:

1. "Header-Off" the damaged TJI® joist around the location of the notch.
 - Reference *Weyerhaeuser Engineered Wood Products Header-Off Span Table* ([TB-319](#)).
2. Remove/replace the damaged TJI® joist or install an additional matched, undamaged TJI® joist within 3" on-center of the damaged member.
 - For joists spaced at 24" on-center (or greater), a matched, undamaged TJI® joist may be required on each side of the damaged member due to sheathing span limits.
 - Reference *TJI® Joists Specifier's Guide* ([TJ-4000](#)) or [Forte®WEB](#) software to verify the allowable span when installing an additional simple span member beside a damaged continuous span member.
3. Contact your Weyerhaeuser representative for detailed notch analysis.

Should you have any questions, or your situation does not meet the conditions and limitations, please contact your Weyerhaeuser representative.

Phone: (888) 453-8358

Email: techsupport@weyerhaeuser.com

Approved Nailed-Repair Assemblies

The layout of the span tables in this technical bulletin is similar to the span tables found in *TJI® Joists Specifier's Guide (TJ-4000)*. The primary difference is an additional column included under each joist spacing. The "No Repair" column provides the maximum joist span without an approved nailed-repair assembly installed on the damaged TJI® joist. The "Repair" column provides the maximum joist span with one of the approved nailed-repair assemblies installed on the damaged TJI® joist. Figure 2 provides construction details for the approved Panel Repair. Figure 3 provides construction details for the approved 2x4 Repair. Either repair assembly may be installed along the side of a TJI® joist, centered on the location of the *Side Flange Notch*.

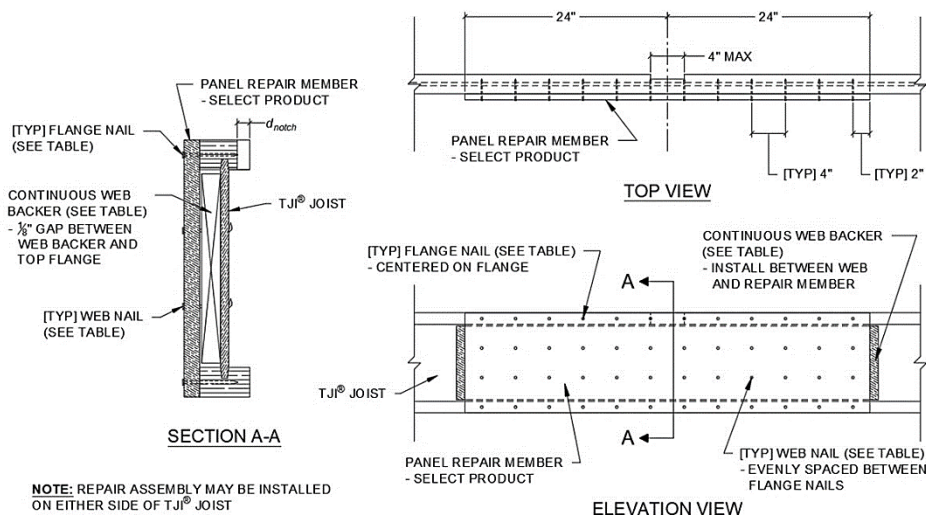

NOTE: REPAIR ASSEMBLY MAY BE INSTALLED ON EITHER SIDE OF TJI® JOIST

PANEL NAILED-REPAIR COMPONENTS [1][2]

TJI® Series	Web Backer Thickness	Panel Product & Nail Size	
		23/32" OSB or 23/32" Plywood Panel	1 1/8" TJI® Rim Board or 1 1/4" TimberStrand® LSL
TJI® 110	5/8" or 3/4"	8d (0.113" x 2 1/2")	8d (0.113" x 2 1/2")
TJI® 210	3/4" or 7/8"	8d (0.113" x 2 1/2")	8d (0.113" x 2 1/2")
TJI® 230 / TJI® 360	7/8" or 1" (net)	8d (0.113" x 2 1/2")	10d (0.128" x 3")
TJI® 560	1 1/2" (2x_)	FLANGE: 8d (0.113" x 2 1/2") WEB: 10d (0.128" x 3")	FLANGE: 10d (0.128" x 3") WEB: 16d (0.162" x 3 1/2")

- [1] Apply construction adhesive at all contact surfaces.
- [2] Repair assembly may be installed on either side of joist.

Figure 2: Detail of Panel Repair for TJI® joists with an inadvertent *Side Flange Notch* in top (compression) flange.

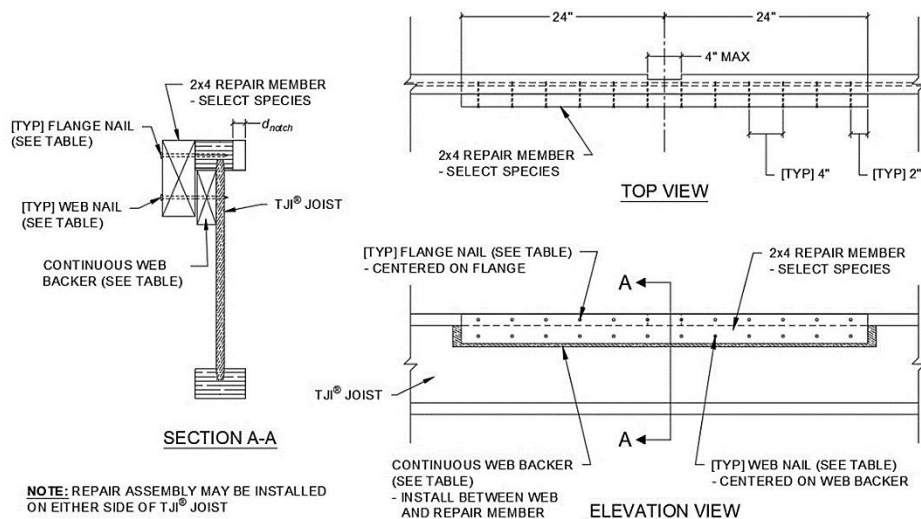

NOTE: REPAIR ASSEMBLY MAY BE INSTALLED ON EITHER SIDE OF TJI® JOIST

2x4 NAILED-REPAIR COMPONENTS [1][2]

TJI® Series	Web Backer Thickness	2x4 Species & Nail Size	
		TimberStrand® LSL or DF-L (Standard) or SPF (No. 2)	
TJI® 110	5/8" or 3/4"	10d (0.128" x 3")	
TJI® 210	3/4" or 7/8"	10d (0.128" x 3")	
TJI® 230 / TJI® 360	7/8" or 1" (net)	10d (0.128" x 3")	
TJI® 560	1 1/2" (2x_)	FLANGE: 10d (0.128" x 3")	WEB: 16d (0.162" x 3 1/2")

- [1] Apply construction adhesive at all contact surfaces.
- [2] Repair assembly may be installed on either side of joist.

Figure 3: Detail of 2x4 Repair for TJI® joists with an inadvertent *Side Flange Notch* in top (compression) flange.

TJI® Joists with a Side Flange Notch Located between End Bearing and Quarter-Span

INDEX OF FLOOR SPAN TABLES

TJI® Series	Joist Depths	Page
TJI® 110	9 ½", 11 7/8", 14", 16"	4
TJI® 210	9 ½", 11 7/8", 14", 16"	4
TJI® 230	9 ½", 11 7/8", 14", 16"	5
TJI® 360	11 7/8", 14", 16", 18", 20"	5
TJI® 560	11 7/8", 14", 16", 18", 20"	6

Location Zones (End Bearing to Quarter-Span)

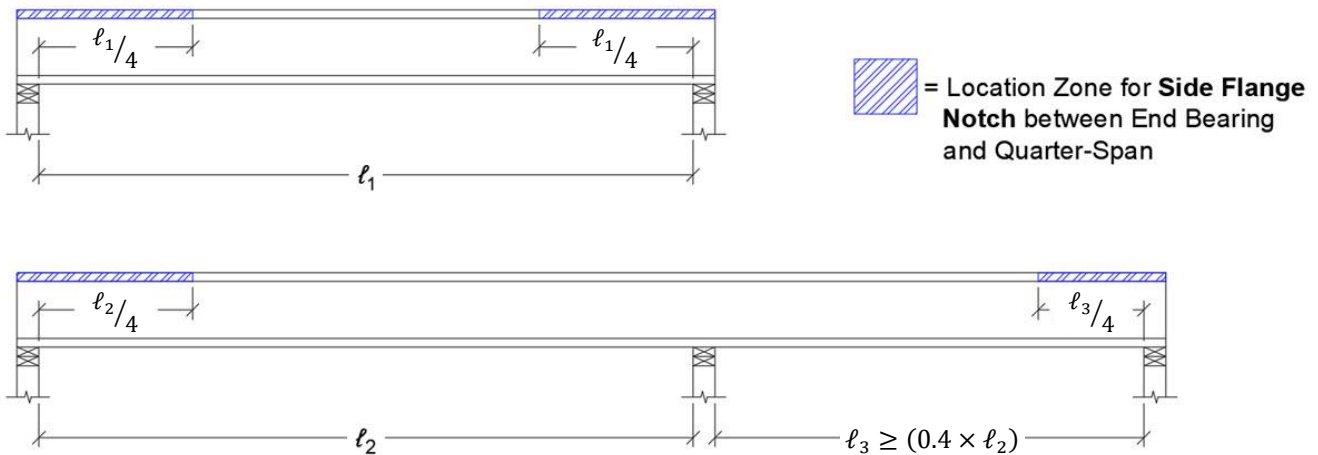

Figure 4: Location zones for a *Side Flange Notch* in simple and continuous TJI® joists (end bearing to quarter-span).

How to Use These Tables

- Confirm the damaged TJI® joist complies with Conditions and Limitations on page 1.
 - Tables assume that the original, undamaged TJI® joist was properly designed as per [TJ-4000](#) or Forte®WEB software.
- Determine the distance of the inadvertent *Side Flange Notch* from inside face of nearest support relative to the as-built span length (ℓ_i).
 - See Figure 4 above.
- Select the appropriate table per the location of the *Side Flange Notch* and the TJI® joist series.
- Identify the design live load and dead load.
- Look up the maximum allowable span for the notch location, joist depth, notch depth (d_{notch}), design loads, joist spacing, and repair option.
- Compare the table span to the as-built span length (ℓ_i).
 - If the table span is less than the as-built span length (ℓ_i), consider one of the alternative options listed on page 1.

General Table Notes

- Tables are based on:
 - Uniform loads.
 - More restrictive of simple or continuous span.
 - Clear distance between supports.
 - Minimum bearing length of 1 ¾" end (no web stiffeners) and 3 ½" intermediate (no web stiffeners).
- Assumed composite action with a single layer of 24" on-center span-rated, glue-nailed floor panels for deflection only.
 - Deflection criteria = L/480 live load (LL); L/240 total load (TL).
- For continuous spans, ratio of short span to long span should be 0.4 or greater to prevent uplift.

Floor Span Tables – Side Flange Notch Located between End Bearing and Quarter-Span

TJI® 110 - MAXIMUM JOIST SPAN WITH SIDE FLANGE NOTCH IN TOP FLANGE (END BEARING TO QUARTER-SPAN)^{[1][2]}

Joist Depth	Notch Depth	40 PSF (Live) \ 10 PSF (Dead)								40 PSF (Live) \ 20 PSF (Dead)							
		12" o.c.		16" o.c.		19.2" o.c.		24" o.c.		12" o.c.		16" o.c.		19.2" o.c.		24" o.c.	
		No Repair	Repair	No Repair	Repair	No Repair	Repair	No Repair	Repair	No Repair	Repair	No Repair	Repair	No Repair	Repair	No Repair	Repair
9 1/2"	≤ 7/16"	16'-11"	-	15'-5"	-	14'-7"	-	13'-6"	13'-7"	16'-11"	-	15'-2"	15'-5"	13'-10"	14'-3"	12'-4"	12'-9"
	≤ 7/8"	16'-2"	16'-11"	14'-0"	15'-0"	12'-9"	13'-8"	11'-5"	12'-3"	14'-9"	15'-10"	12'-9"	13'-8"	11'-8"	12'-6"	10'-5"	11'-2"
11 7/8"	≤ 7/16"	20'-2"	-	18'-5"	-	17'-0"	17'-4"	15'-3"	15'-4"	19'-8"	20'-2"	17'-0"	17'-8"	15'-6"	16'-0"	12'-9"	-
	≤ 7/8"	18'-3"	19'-7"	15'-9"	16'-11"	14'-4"	15'-5"	12'-10"	13'-9"	16'-7"	17'-10"	14'-4"	15'-5"	13'-1"	14'-1"	11'-8"	12'-7"
14"	≤ 7/16"	22'-10"	-	20'-4"	20'-10"	18'-6"	19'-2"	15'-4"	-	21'-5"	22'-2"	18'-6"	19'-2"	16'-0"	-	12'-9"	-
	≤ 7/8"	19'-10"	21'-3"	17'-2"	18'-5"	15'-8"	16'-9"	14'-0"	15'-0"	18'-1"	19'-5"	15'-8"	16'-9"	14'-3"	15'-4"	12'-9"	-
16"	≤ 7/16"	25'-2"	25'-4"	21'-9"	22'-6"	19'-2"	-	15'-4"	-	22'-11"	23'-9"	19'-2"	-	16'-0"	-	12'-9"	-
	≤ 7/8"	21'-3"	22'-9"	18'-4"	19'-8"	16'-9"	18'-0"	15'-0"	15'-4"	19'-4"	20'-9"	16'-9"	18'-0"	15'-3"	16'-0"	12'-9"	-

[1] Confirm accordance with Conditions and Limitations on Page 1 and reference Figure 4, How to Use These Tables, and General Table Notes on Page 3.

[2] Table applicable to TJI® joists with one (1) inadvertent Side Flange Notch located between nearest end bearing and quarter-point of the joist clear span.

TJI® 210 - MAXIMUM JOIST SPAN WITH SIDE FLANGE NOTCH IN TOP FLANGE (END BEARING TO QUARTER-SPAN)^{[1][2]}

Joist Depth	Notch Depth	40 PSF (Live) \ 10 PSF (Dead)								40 PSF (Live) \ 20 PSF (Dead)							
		12" o.c.		16" o.c.		19.2" o.c.		24" o.c.		12" o.c.		16" o.c.		19.2" o.c.		24" o.c.	
		No Repair	Repair	No Repair	Repair	No Repair	Repair	No Repair	Repair	No Repair	Repair	No Repair	Repair	No Repair	Repair	No Repair	Repair
9 1/2"	≤ 1/2"	17'-9"	-	16'-2"	-	15'-3"	-	14'-3"	-	17'-9"	-	16'-2"	-	15'-2"	15'-3"	13'-6"	14'-0"
	≤ 1"	17'-9"	-	15'-4"	16'-2"	14'-0"	15'-0"	12'-6"	13'-5"	16'-2"	17'-4"	14'-0"	15'-0"	12'-9"	13'-8"	11'-5"	12'-3"
11 7/8"	≤ 1/2"	21'-1"	-	19'-3"	-	18'-2"	-	16'-8"	16'-11"	21'-1"	-	18'-8"	19'-3"	17'-0"	17'-8"	14'-2"	-
	≤ 1"	20'-0"	21'-1"	17'-3"	18'-6"	15'-9"	16'-11"	14'-1"	15'-1"	18'-3"	19'-7"	15'-9"	16'-11"	14'-4"	15'-5"	12'-10"	13'-9"
14"	≤ 1/2"	23'-11"	-	21'-10"	-	20'-4"	20'-8"	17'-0"	-	23'-6"	23'-11"	20'-4"	21'-1"	17'-9"	-	14'-2"	-
	≤ 1"	21'-9"	23'-4"	18'-10"	20'-2"	17'-2"	18'-5"	15'-4"	16'-5"	19'-10"	21'-3"	17'-2"	18'-5"	15'-8"	16'-9"	14'-0"	14'-2"
16"	≤ 1/2"	26'-6"	-	23'-10"	24'-3"	21'-4"	-	17'-0"	-	25'-2"	26'-0"	21'-4"	-	17'-9"	-	14'-2"	-
	≤ 1"	23'-3"	25'-0"	20'-1"	21'-7"	18'-4"	19'-8"	16'-5"	17'-0"	21'-3"	22'-9"	18'-4"	19'-8"	16'-9"	17'-9"	14'-2"	-

[1] Confirm accordance with Conditions and Limitations on Page 1 and reference Figure 4, How to Use These Tables, and General Table Notes on Page 3.

[2] Table applicable to TJI® joists with one (1) inadvertent Side Flange Notch located between nearest end bearing and quarter-point of the joist clear span.

TJI® 230 - MAXIMUM JOIST SPAN WITH SIDE FLANGE NOTCH IN TOP FLANGE (END BEARING TO QUARTER-SPAN)^{[1][2]}

Joist Depth	Notch Depth	40 PSF (Live) \ 10 PSF (Dead)								40 PSF (Live) \ 20 PSF (Dead)							
		12" o.c.		16" o.c.		19.2" o.c.		24" o.c.		12" o.c.		16" o.c.		19.2" o.c.		24" o.c.	
		No Repair	Repair	No Repair	Repair	No Repair	Repair	No Repair	Repair	No Repair	Repair	No Repair	Repair	No Repair	Repair	No Repair	Repair
9 1/2"	≤ 9/16"	18'-3"	-	16'-8"	-	15'-9"	-	14'-8"	-	18'-3"	-	16'-8"	-	15'-9"	-	14'-3"	14'-8"
	≤ 1 1/8"	18'-3"	-	16'-2"	16'-8"	14'-9"	15'-9"	13'-2"	14'-2"	17'-1"	18'-3"	14'-9"	15'-10"	13'-5"	14'-5"	12'-0"	12'-11"
11 7/8"	≤ 9/16"	21'-8"	-	19'-10"	-	18'-8"	-	17'-5"	-	21'-8"	-	19'-8"	19'-10"	18'-0"	18'-7"	15'-11"	-
	≤ 1 1/8"	21'-1"	21'-8"	18'-3"	19'-7"	16'-7"	17'-10"	14'-10"	15'-11"	19'-3"	20'-7"	16'-7"	17'-10"	15'-2"	16'-3"	13'-6"	14'-6"
14"	≤ 9/16"	24'-8"	-	22'-6"	-	21'-2"	-	19'-2"	-	24'-8"	-	21'-5"	22'-2"	19'-7"	19'-11"	15'-11"	-
	≤ 1 1/8"	22'-11"	24'-7"	19'-10"	21'-3"	18'-1"	19'-5"	16'-2"	17'-4"	20'-11"	22'-5"	18'-1"	19'-5"	16'-6"	17'-9"	14'-9"	15'-10"
16"	≤ 9/16"	27'-3"	-	24'-10"	-	22'-11"	23'-5"	19'-2"	-	26'-6"	27'-3"	22'-11"	23'-9"	19'-11"	-	15'-11"	-
	≤ 1 1/8"	24'-6"	26'-4"	21'-3"	22'-9"	19'-4"	20'-9"	17'-4"	18'-7"	22'-5"	24'-0"	19'-4"	20'-9"	17'-8"	18'-11"	15'-9"	15'-11"

[1] Confirm accordance with Conditions and Limitations on Page 1 and reference Figure 4, How to Use These Tables, and General Table Notes on Page 3.
 [2] Table applicable to TJI® joists with one (1) inadvertent Side Flange Notch located between nearest end bearing and quarter-point of the joist clear span.

TJI® 360 - MAXIMUM JOIST SPAN WITH SIDE FLANGE NOTCH IN TOP FLANGE (END BEARING TO QUARTER-SPAN)^{[1][2]}

Joist Depth	Notch Depth	40 PSF (Live) \ 10 PSF (Dead)								40 PSF (Live) \ 20 PSF (Dead)							
		12" o.c.		16" o.c.		19.2" o.c.		24" o.c.		12" o.c.		16" o.c.		19.2" o.c.		24" o.c.	
		No Repair	Repair	No Repair	Repair	No Repair	Repair	No Repair	Repair	No Repair	Repair	No Repair	Repair	No Repair	Repair	No Repair	Repair
11 7/8"	≤ 9/16"	22'-11"	-	20'-11"	-	19'-8"	-	18'-4"	-	22'-11"	-	20'-11"	-	19'-8"	-	16'-3"	-
	≤ 1 1/8"	22'-11"	-	20'-11"	-	19'-8"	-	18'-0"	18'-4"	22'-11"	-	20'-2"	20'-11"	18'-5"	19'-8"	16'-3"	-
14"	≤ 9/16"	26'-0"	-	23'-8"	-	22'-4"	-	19'-6"	-	26'-0"	-	23'-8"	-	20'-4"	-	16'-3"	-
	≤ 1 1/8"	26'-0"	-	23'-8"	-	22'-0"	22'-4"	19'-6"	-	25'-5"	26'-0"	22'-0"	23'-7"	20'-0"	20'-4"	16'-3"	-
16"	≤ 9/16"	28'-9"	-	26'-2"	-	24'-5"	-	19'-6"	-	28'-9"	-	24'-5"	-	20'-4"	-	16'-3"	-
	≤ 1 1/8"	28'-9"	-	25'-9"	26'-2"	23'-6"	24'-5"	19'-6"	-	27'-2"	28'-9"	23'-6"	24'-5"	20'-4"	-	16'-3"	-
18"	≤ 9/16"	31'-5"	-	28'-8"	-	24'-5"	-	19'-6"	-	30'-2" ^[3]	- ^[3]	22'-7" ^[3]	- ^[3]	18'-9" ^[3]	- ^[3]	15'-0" ^[3]	- ^[3]
	≤ 1 1/8"	31'-5"	-	27'-4"	28'-8"	24'-5"	-	19'-6"	-	27'-9" ^[3]	29'-9" ^[3]	22'-7" ^[3]	- ^[3]	18'-9" ^[3]	- ^[3]	15'-0" ^[3]	- ^[3]
20"	≤ 9/16"	34'-0"	-	29'-4"	-	24'-5"	-	19'-6"	-	30'-2" ^[3]	- ^[3]	22'-7" ^[3]	- ^[3]	18'-9" ^[3]	- ^[3]	15'-0" ^[3]	- ^[3]
	≤ 1 1/8"	33'-4"	34'-0"	28'-10"	29'-4"	24'-5"	-	19'-6"	-	29'-3" ^[3]	30'-2" ^[3]	22'-7" ^[3]	- ^[3]	18'-9" ^[3]	- ^[3]	15'-0" ^[3]	- ^[3]

[1] Confirm accordance with Conditions and Limitations on Page 1 and reference Figure 4, How to Use These Tables, and General Table Notes on Page 3.
 [2] Table applicable to TJI® joists with one (1) inadvertent Side Flange Notch located between nearest end bearing and quarter-point of the joist clear span.
 [3] Span value considers design load of 40 PSF (Live) \ 25 PSF (Dead).

TJI® 560 - MAXIMUM JOIST SPAN WITH SIDE FLANGE NOTCH IN TOP FLANGE (END BEARING TO QUARTER-SPAN)^{[1][2]}

Joist Depth	Notch Depth	40 PSF (Live) \ 10 PSF (Dead)								40 PSF (Live) \ 20 PSF (Dead)							
		12" o.c.		16" o.c.		19.2" o.c.		24" o.c.		12" o.c.		16" o.c.		19.2" o.c.		24" o.c.	
		No Repair	Repair	No Repair	Repair	No Repair	Repair	No Repair	Repair	No Repair	Repair	No Repair	Repair	No Repair	Repair	No Repair	Repair
11 7/8"	≤ 7/8"	26'-1"	-	23'-8"	-	22'-4"	-	20'-9"	-	26'-1"	-	23'-8"	-	22'-4"	-	19'-10"	-
	≤ 1 3/4"	26'-1"	-	23'-8"	-	22'-4"	-	20'-9"	-	26'-1"	-	23'-8"	-	22'-4"	-	19'-10"	-
14"	≤ 7/8"	29'-6"	-	26'-10"	-	25'-4"	-	23'-6"	-	29'-6"	-	26'-10"	-	24'-10"	-	19'-10"	-
	≤ 1 3/4"	29'-6"	-	26'-10"	-	25'-4"	-	23'-6"	-	29'-6"	-	26'-10"	-	24'-10"	-	19'-10"	-
16"	≤ 7/8"	32'-8"	-	29'-8"	-	28'-0"	-	23'-10"	-	32'-8"	-	29'-8"	-	24'-10"	-	19'-10"	-
	≤ 1 3/4"	32'-8"	-	29'-8"	-	28'-0"	-	23'-10"	-	32'-8"	-	29'-2"	29'-8"	24'-10"	-	19'-10"	-
18"	≤ 7/8"	35'-8"	-	32'-5"	-	29'-10"	-	23'-10"	-	35'-8" ^[3]	- ^[3]	27'-7" ^[3]	- ^[3]	22'-11" ^[3]	- ^[3]	18'-4" ^[3]	- ^[3]
	≤ 1 3/4"	35'-8"	-	32'-5"	-	29'-10"	-	23'-10"	-	34'-5" ^[3]	35'-8" ^[3]	27'-7" ^[3]	- ^[3]	22'-11" ^[3]	- ^[3]	18'-4" ^[3]	- ^[3]
20"	≤ 7/8"	38'-7"	-	35'-1"	-	29'-10"	-	23'-10"	-	36'-9" ^[3]	- ^[3]	27'-7" ^[3]	- ^[3]	22'-11" ^[3]	- ^[3]	18'-4" ^[3]	- ^[3]
	≤ 1 3/4"	38'-7"	-	35'-1"	-	29'-10"	-	23'-10"	-	36'-3" ^[3]	36'-9" ^[3]	27'-7" ^[3]	- ^[3]	22'-11" ^[3]	- ^[3]	18'-4" ^[3]	- ^[3]

[1] Confirm accordance with Conditions and Limitations on Page 1 and reference Figure 4, How to Use These Tables, and General Table Notes on Page 3.
 [2] Table applicable to TJI® joists with one (1) inadvertent *Side Flange Notch* located between nearest end bearing and quarter-point of the joist clear span.
 [3] Span value considers design load of 40 PSF (Live) \ 25 PSF (Dead).

TJI® Joists with a Side Flange Notch Located between Quarter-Span and Mid-Span

INDEX OF FLOOR SPAN TABLES

TJI® Series	Joist Depths	Page
TJI® 110	9 ½", 11 ⅞", 14", 16"	8
TJI® 210	9 ½", 11 ⅞", 14", 16"	8
TJI® 230	9 ½", 11 ⅞", 14", 16"	9
TJI® 360	11 ⅞", 14", 16", 18", 20"	9
TJI® 560	11 ⅞", 14", 16", 18", 20"	10

Location Zones (Quarter-Span to Mid-Span)

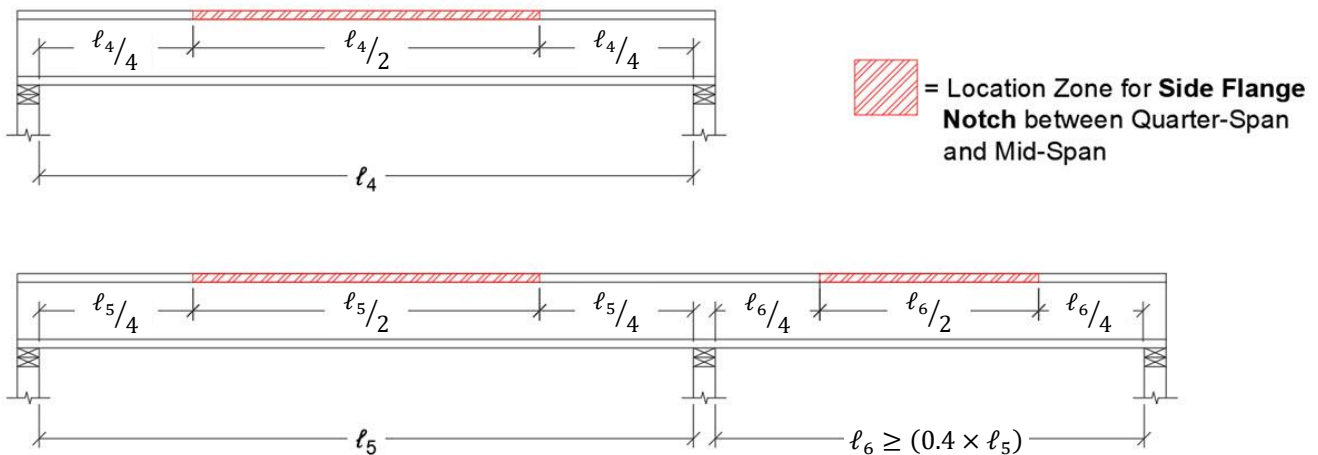

Figure 5: Location zones for a Side Flange Notch in simple and continuous TJI® joists (quarter-span to mid-span).

How to Use These Tables

- Confirm the damaged TJI® joist complies with Conditions and Limitations on page 1.
 - Tables assume that the original, undamaged TJI® joist was properly designed as per [TJ-4000](#) or Forte®WEB software.
- Determine the distance of the inadvertent Side Flange Notch from inside face of nearest support, relative to the as-built span length (l_i).
 - See Figure 5 above.
- Select the appropriate table per the location of the Side Flange Notch and the TJI® joist series.
- Identify the design live load and dead load.
- Look up the maximum allowable span for the notch location, joist depth, notch depth (d_{notch}), design loads, joist spacing, and repair option.
- Compare the table span to the as-built span length (l_i).
 - If the table span is less than the as-built span length (l_i), consider one of the alternative options listed on page 1.

General Table Notes

- Tables are based on:
 - Uniform loads.
 - More restrictive of simple or continuous span.
 - Clear distance between supports.
 - Minimum bearing length of 1 ¾" end (no web stiffeners) and 3 ½" intermediate (no web stiffeners).
- Assumed composite action with a single layer of 24" on-center span-rated, glue-nailed floor panels for deflection only.
 - Deflection criteria = L/480 live load (LL); L/240 total load (TL).
- For continuous spans, ratio of short span to long span should be 0.4 or greater to prevent uplift.

Floor Span Tables – Side Flange Notch Located between Quarter-Span and Mid-Span

TJI® 110 - MAXIMUM JOIST SPAN WITH SIDE FLANGE NOTCH IN TOP FLANGE (QUARTER-SPAN TO MID-SPAN)^{[1][2]}

Joist Depth	Notch Depth	40 PSF (Live) \ 10 PSF (Dead)								40 PSF (Live) \ 20 PSF (Dead)							
		12" o.c.		16" o.c.		19.2" o.c.		24" o.c.		12" o.c.		16" o.c.		19.2" o.c.		24" o.c.	
		No Repair	Repair	No Repair	Repair	No Repair	Repair	No Repair	Repair	No Repair	Repair	No Repair	Repair	No Repair	Repair	No Repair	Repair
9 1/2"	≤ 7/16"	16'-7"	16'-11"	14'-4"	15'-2"	13'-1"	13'-10"	11'-8"	12'-4"	15'-2"	16'-0"	13'-1"	13'-10"	11'-11"	12'-7"	10'-8"	11'-3"
	≤ 7/8"	14'-0"	15'-0"	12'-1"	13'-0"	11'-0"	11'-10"	9'-10"	10'-7"	12'-9"	13'-8"	11'-0"	11'-10"	10'-1"	10'-10"	9'-0"	9'-8"
11 7/8"	≤ 7/16"	18'-8"	19'-8"	16'-2"	17'-0"	14'-9"	15'-6"	13'-2"	13'-11"	17'-0"	18'-0"	14'-9"	15'-6"	13'-5"	14'-2"	12'-0"	12'-8"
	≤ 7/8"	15'-9"	16'-11"	13'-7"	14'-7"	12'-5"	13'-4"	11'-1"	11'-11"	14'-4"	15'-5"	12'-5"	13'-4"	11'-4"	12'-2"	10'-1"	10'-10"
14"	≤ 7/16"	20'-4"	21'-5"	17'-7"	18'-6"	16'-0"	16'-11"	14'-4"	15'-1"	18'-6"	19'-7"	16'-0"	16'-11"	14'-7"	15'-5"	12'-9"	-
	≤ 7/8"	17'-2"	18'-5"	14'-10"	15'-11"	13'-6"	14'-6"	12'-1"	13'-0"	15'-8"	16'-9"	13'-6"	14'-6"	12'-4"	13'-3"	11'-0"	11'-10"
16"	≤ 7/16"	21'-9"	22'-11"	18'-10"	19'-10"	17'-2"	18'-1"	15'-4"	-	19'-10"	20'-11"	17'-2"	18'-1"	15'-8"	16'-0"	12'-9"	-
	≤ 7/8"	18'-4"	19'-8"	15'-11"	17'-0"	14'-6"	15'-7"	12'-11"	13'-11"	16'-9"	18'-0"	14'-6"	15'-7"	13'-2"	14'-2"	11'-10"	12'-8"

[1] Confirm accordance with Conditions and Limitations on Page 1 and reference Figure 5, How to Use These Tables, and General Table Notes on Page 7.

[2] Table applicable to TJI® joists with one (1) inadvertent Side Flange Notch located between quarter-point and mid-point of the joist clear span.

TJI® 210 - MAXIMUM JOIST SPAN WITH SIDE FLANGE NOTCH IN TOP FLANGE (QUARTER-SPAN TO MID-SPAN)^{[1][2]}

Joist Depth	Notch Depth	40 PSF (Live) \ 10 PSF (Dead)								40 PSF (Live) \ 20 PSF (Dead)							
		12" o.c.		16" o.c.		19.2" o.c.		24" o.c.		12" o.c.		16" o.c.		19.2" o.c.		24" o.c.	
		No Repair	Repair	No Repair	Repair	No Repair	Repair	No Repair	Repair	No Repair	Repair	No Repair	Repair	No Repair	Repair	No Repair	Repair
9 1/2"	≤ 1/2"	17'-9"	-	15'-9"	16'-2"	14'-4"	15'-2"	12'-10"	13'-6"	16'-7"	17'-6"	14'-4"	15'-2"	13'-1"	13'-10"	11'-8"	12'-4"
	≤ 1"	15'-4"	16'-6"	13'-3"	14'-3"	12'-1"	13'-0"	10'-10"	11'-7"	14'-0"	15'-0"	12'-1"	13'-0"	11'-0"	11'-10"	9'-10"	10'-7"
11 7/8"	≤ 1/2"	20'-6"	21'-1"	17'-9"	18'-8"	16'-2"	17'-0"	14'-5"	15'-3"	18'-8"	19'-8"	16'-2"	17'-0"	14'-9"	15'-6"	13'-2"	13'-11"
	≤ 1"	17'-3"	18'-6"	14'-11"	16'-0"	13'-8"	14'-8"	12'-2"	13'-1"	15'-9"	16'-11"	13'-8"	14'-8"	12'-5"	13'-4"	11'-1"	11'-11"
14"	≤ 1/2"	22'-3"	23'-6"	19'-3"	20'-4"	17'-7"	18'-7"	15'-9"	16'-7"	20'-4"	21'-5"	17'-7"	18'-7"	16'-0"	16'-11"	14'-2"	-
	≤ 1"	18'-10"	20'-2"	16'-3"	17'-5"	14'-10"	15'-11"	13'-3"	14'-3"	17'-2"	18'-5"	14'-10"	15'-11"	13'-6"	14'-6"	12'-1"	13'-0"
16"	≤ 1/2"	23'-10"	25'-2"	20'-7"	21'-9"	18'-10"	19'-10"	16'-10"	17'-0"	21'-9"	22'-11"	18'-10"	19'-10"	17'-2"	17'-9"	14'-2"	-
	≤ 1"	20'-1"	21'-7"	17'-5"	18'-8"	15'-11"	17'-1"	14'-2"	15'-3"	18'-4"	19'-8"	15'-11"	17'-1"	14'-6"	15'-7"	12'-11"	13'-11"

[1] Confirm accordance with Conditions and Limitations on Page 1 and reference Figure 5, How to Use These Tables, and General Table Notes on Page 7.

[2] Table applicable to TJI® joists with one (1) inadvertent Side Flange Notch located between quarter-point and mid-point of the joist clear span.

TJI® 230 - MAXIMUM JOIST SPAN WITH SIDE FLANGE NOTCH IN TOP FLANGE (QUARTER-SPAN TO MID-SPAN)^{[1][2]}

Joist Depth	Notch Depth	40 PSF (Live) \ 10 PSF (Dead)								40 PSF (Live) \ 20 PSF (Dead)							
		12" o.c.		16" o.c.		19.2" o.c.		24" o.c.		12" o.c.		16" o.c.		19.2" o.c.		24" o.c.	
		No Repair	Repair	No Repair	Repair	No Repair	Repair	No Repair	Repair	No Repair	Repair	No Repair	Repair	No Repair	Repair	No Repair	Repair
9 1/2"	≤ 9/16"	18'-3"	-	16'-7"	16'-8"	15'-1"	15'-9"	13'-6"	14'-3"	17'-6"	18'-3"	15'-1"	15'-11"	13'-9"	14'-7"	12'-4"	13'-0"
	≤ 1 1/8"	16'-2"	17'-4"	14'-0"	15'-0"	12'-9"	13'-8"	11'-5"	12'-3"	14'-9"	15'-10"	12'-9"	13'-8"	11'-8"	12'-6"	10'-5"	11'-2"
11 7/8"	≤ 9/16"	21'-7"	21'-8"	18'-8"	19'-8"	17'-0"	18'-0"	15'-3"	16'-1"	19'-8"	20'-9"	17'-0"	18'-0"	15'-6"	16'-5"	13'-11"	14'-8"
	≤ 1 1/8"	18'-3"	19'-7"	15'-9"	16'-11"	14'-4"	15'-5"	12'-10"	13'-9"	16'-7"	17'-10"	14'-4"	15'-5"	13'-1"	14'-1"	11'-8"	12'-7"
14"	≤ 9/16"	23'-6"	24'-8"	20'-4"	21'-5"	18'-7"	19'-7"	16'-7"	17'-6"	21'-5"	22'-7"	18'-7"	19'-7"	16'-11"	17'-10"	15'-1"	15'-11"
	≤ 1 1/8"	19'-10"	21'-3"	17'-2"	18'-5"	15'-8"	16'-10"	14'-0"	15'-0"	18'-1"	19'-5"	15'-8"	16'-10"	14'-3"	15'-4"	12'-9"	13'-8"
16"	≤ 9/16"	25'-2"	26'-6"	21'-9"	22'-11"	19'-10"	20'-11"	17'-9"	18'-8"	22'-11"	24'-2"	19'-10"	20'-11"	18'-1"	19'-1"	15'-11"	-
	≤ 1 1/8"	21'-3"	22'-9"	18'-4"	19'-8"	16'-9"	18'-0"	15'-0"	16'-1"	19'-4"	20'-9"	16'-9"	18'-0"	15'-3"	16'-5"	13'-8"	14'-8"

[1] Confirm accordance with Conditions and Limitations on Page 1 and reference Figure 5, How to Use These Tables, and General Table Notes on Page 7.
 [2] Table applicable to TJI® joists with one (1) inadvertent Side Flange Notch located between quarter-point and mid-point of the joist clear span.

TJI® 360 - MAXIMUM JOIST SPAN WITH SIDE FLANGE NOTCH IN TOP FLANGE (QUARTER-SPAN TO MID-SPAN)^{[1][2]}

Joist Depth	Notch Depth	40 PSF (Live) \ 10 PSF (Dead)								40 PSF (Live) \ 20 PSF (Dead)							
		12" o.c.		16" o.c.		19.2" o.c.		24" o.c.		12" o.c.		16" o.c.		19.2" o.c.		24" o.c.	
		No Repair	Repair	No Repair	Repair	No Repair	Repair	No Repair	Repair	No Repair	Repair	No Repair	Repair	No Repair	Repair	No Repair	Repair
11 7/8"	≤ 9/16"	22'-11"	-	20'-11"	-	19'-8"	-	18'-4"	-	22'-11"	-	20'-8"	20'-11"	18'-10"	19'-8"	16'-3"	-
	≤ 1 1/8"	22'-1"	22'-11"	19'-1"	20'-6"	17'-5"	18'-8"	15'-7"	16'-9"	20'-2"	21'-7"	17'-5"	18'-8"	15'-11"	17'-1"	14'-2"	15'-3"
14"	≤ 9/16"	26'-0"	-	23'-8"	-	22'-4"	-	19'-6"	-	26'-0"	-	22'-6"	23'-8"	20'-4"	-	16'-3"	-
	≤ 1 1/8"	24'-1"	25'-10"	20'-10"	22'-4"	19'-0"	20'-5"	17'-0"	18'-3"	22'-0"	23'-7"	19'-0"	20'-5"	17'-4"	18'-7"	15'-6"	16'-3"
16"	≤ 9/16"	28'-9"	-	26'-2"	-	24'-1"	24'-5"	19'-6"	-	27'-10"	28'-9"	24'-1"	24'-5"	20'-4"	-	16'-3"	-
	≤ 1 1/8"	25'-9"	27'-8"	22'-4"	23'-11"	20'-4"	21'-10"	18'-2"	19'-6"	23'-6"	25'-3"	20'-4"	21'-10"	18'-7"	19'-11"	16'-3"	-
18"	≤ 9/16"	31'-5"	-	28'-1"	28'-8"	24'-5"	-	19'-6"	-	28'-5" ^[3]	30'-0" ^[3]	22'-7" ^[3]	- ^[3]	18'-9" ^[3]	- ^[3]	15'-0" ^[3]	- ^[3]
	≤ 1 1/8"	27'-4"	29'-4"	23'-8"	25'-5"	21'-7"	23'-2"	19'-4"	19'-6"	24'-0" ^[3]	25'-9" ^[3]	20'-9" ^[3]	22'-3" ^[3]	18'-9" ^[3]	- ^[3]	15'-0" ^[3]	- ^[3]
20"	≤ 9/16"	34'-0"	-	29'-4"	-	24'-5"	-	19'-6"	-	29'-11" ^[3]	30'-2" ^[3]	22'-7" ^[3]	- ^[3]	18'-9" ^[3]	- ^[3]	15'-0" ^[3]	- ^[3]
	≤ 1 1/8"	28'-10"	30'-11"	25'-0"	26'-9"	22'-9"	24'-5"	19'-6"	-	25'-4" ^[3]	27'-2" ^[3]	21'-11" ^[3]	22'-7" ^[3]	18'-9" ^[3]	- ^[3]	15'-0" ^[3]	- ^[3]

[1] Confirm accordance with Conditions and Limitations on Page 1 and reference Figure 5, How to Use These Tables, and General Table Notes on Page 7.
 [2] Table applicable to TJI® joists with one (1) inadvertent Side Flange Notch located between quarter-point and mid-point of the joist clear span.
 [3] Span value considers design load of 40 PSF (Live) \ 25 PSF (Dead).

TJI® 560 - MAXIMUM JOIST SPAN WITH SIDE FLANGE NOTCH IN TOP FLANGE (QUARTER-SPAN TO MID-SPAN)^{[1][2]}

Joist Depth	Notch Depth	40 PSF (Live) \ 10 PSF (Dead)								40 PSF (Live) \ 20 PSF (Dead)							
		12" o.c.		16" o.c.		19.2" o.c.		24" o.c.		12" o.c.		16" o.c.		19.2" o.c.		24" o.c.	
		No Repair	Repair	No Repair	Repair	No Repair	Repair	No Repair	Repair	No Repair	Repair	No Repair	Repair	No Repair	Repair	No Repair	Repair
11 7/8"	≤ 7/8"	26'-1"	-	23'-8"	-	22'-4"	-	20'-9"	-	26'-1"	-	23'-8"	-	22'-4"	-	19'-10"	-
	≤ 1 3/4"	26'-1"	-	23'-8"	-	21'-8"	22'-4"	19'-4"	20'-9"	25'-0"	26'-1"	21'-8"	23'-3"	19'-9"	21'-2"	17'-8"	18'-11"
14"	≤ 7/8"	29'-6"	-	26'-10"	-	25'-4"	-	23'-6"	-	29'-6"	-	26'-10"	-	24'-10"	-	19'-10"	-
	≤ 1 3/4"	29'-6"	-	25'-10"	26'-10"	23'-7"	25'-4"	21'-1"	22'-8"	27'-3"	29'-3"	23'-7"	25'-4"	21'-6"	23'-1"	19'-3"	19'-10"
16"	≤ 7/8"	32'-8"	-	29'-8"	-	28'-0"	-	23'-10"	-	32'-8"	-	29'-8"	-	24'-10"	-	19'-10"	-
	≤ 1 3/4"	32'-0"	32'-8"	27'-8"	29'-8"	25'-3"	27'-1"	22'-7"	23'-10"	29'-2"	31'-4"	25'-3"	27'-1"	23'-1"	24'-9"	19'-10"	-
18"	≤ 7/8"	35'-8"	-	32'-5"	-	29'-10"	-	23'-10"	-	35'-3" ^[3]	35'-8" ^[3]	27'-7" ^[3]	- ^[3]	22'-11" ^[3]	- ^[3]	18'-4" ^[3]	- ^[3]
	≤ 1 3/4"	34'-0"	35'-8"	29'-5"	31'-6"	26'-10"	28'-9"	23'-10"	-	29'-9" ^[3]	31'-11" ^[3]	25'-9" ^[3]	27'-7" ^[3]	22'-11" ^[3]	- ^[3]	18'-4" ^[3]	- ^[3]
20"	≤ 7/8"	38'-7"	-	35'-1"	-	29'-10"	-	23'-10"	-	36'-9" ^[3]	- ^[3]	27'-7" ^[3]	- ^[3]	22'-11" ^[3]	- ^[3]	18'-4" ^[3]	- ^[3]
	≤ 1 3/4"	35'-10"	38'-5"	31'-0"	33'-3"	28'-3"	29'-10"	23'-10"	-	31'-5" ^[3]	33'-8" ^[3]	27'-2" ^[3]	27'-7" ^[3]	22'-11" ^[3]	- ^[3]	18'-4" ^[3]	- ^[3]

[1] Confirm accordance with Conditions and Limitations on Page 1 and reference Figure 5, How to Use These Tables, and General Table Notes on Page 7.

[2] Table applicable to TJI® joists with one (1) inadvertent *Side Flange Notch* located between quarter-point and mid-point of the joist clear span.

[3] Span value considers design load of 40 PSF (Live) \ 25 PSF (Dead).